



Outdoor Armor Water Heater Installation & Operation Manual Models: 201 - 286

⚠ WARNING: If the information in this manual is not followed exactly, a fire or explosion may result causing property damage, personal injury or loss of life.

-- This water heater **MUST NOT** be installed in any location where gasoline or flammable vapors are likely to be present.

-- WHAT TO DO IF YOU SMELL GAS

- Do not try to light any appliance.
- Do not touch any electric switch; do not use any phone in your building.
- Immediately call your gas supplier from a near by phone. Follow the gas supplier's instructions.
- If you cannot reach your gas supplier, call the fire department.
- Installation and service must be performed by a qualified installer, service agency, or the gas supplier.

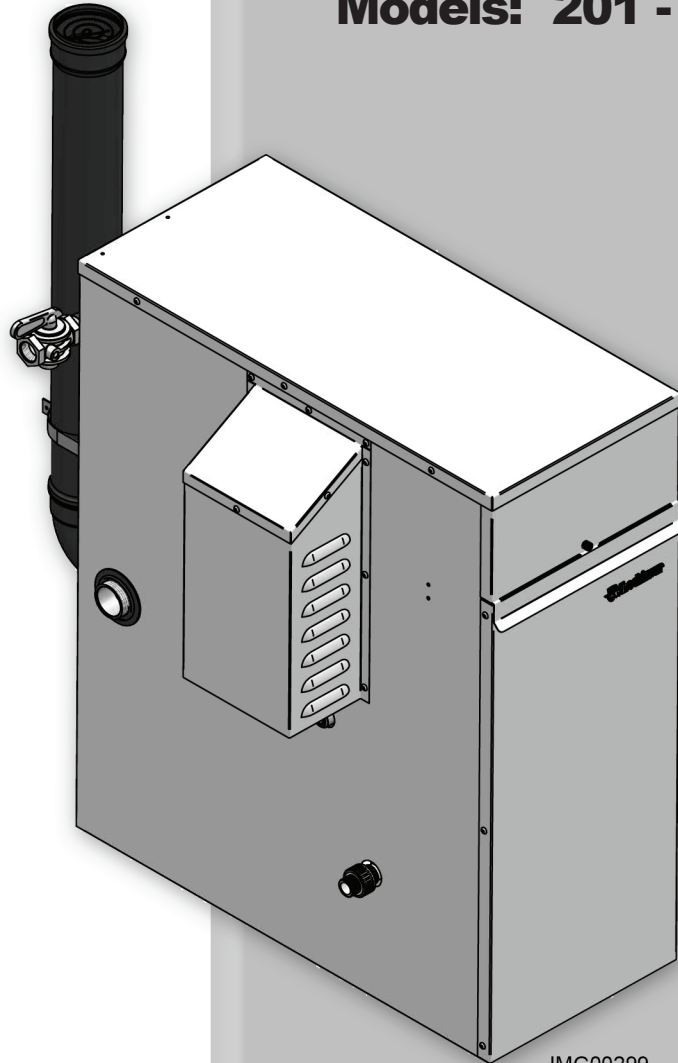

IMG00299



⚠ WARNING This manual must only be used by a qualified heating installer / service technician. Read all instructions, including this manual and the Outdoor Armor Water Heater Service Manual, before installing. Perform steps in the order given. Failure to comply could result in severe personal injury, death, or substantial property damage.

Save this manual for future reference.

Contents

HAZARD DEFINITIONS	2	5. FIELD WIRING	
PLEASE READ BEFORE PROCEEDING	3	Line Voltage Connections	24
THE OUTDOOR ARMOR WATER HEATER -- HOW IT WORKS	4-5	Low Voltage Connections	24
RATINGS	6	Wiring of the Cascade.....	26
1. DETERMINE WATER HEATER LOCATION		6. CONDENSATE DISPOSAL	
Provide Clearances.....	8	Condensate Drain	28
Outdoor Vent / Air Intake Location.....	8	7. STARTUP	29-33
Flooring and Foundation	8	8. OPERATING INFORMATION	
Prevent Combustion Air Contamination.....	9	General.....	34
Corrosive Contaminants and Sources	9	Cascade	36
2. PREPARE WATER HEATER		Sequence of Operation	37
Remove Water Heater from Wood Pallet	10	Outdoor Armor Water Heater Control Module	38
Gas Conversions.....	11-11	Status Display Screens	39-41
Leveling the Water Heater.....	11	9. MAINTENANCE	
3. SYSTEM PIPING		Maintenance & Annual Startup	42-46
System Water Piping Methods.....	12	10. DIAGRAMS	
Flow Switch and Relief Valve Installation	12-13	Ladder Diagram	47
Flow Switch Adjustment.....	13	Wiring Diagram.....	48
Scalding.....	13	Revision Notes	Back Cover
Water Chemistry.....	14		
Piping Components.....	14		
4. GAS CONNECTIONS			
Connecting Gas Supply Piping	20		
Natural Gas	21		
Pipe Sizing for Natural Gas	21		
Natural Gas Supply Pressure Requirements	21		
Propane Gas	21		
Pipe Sizing for Propane Gas	21		
Propane Supply Pressure Requirements	21		
Check Inlet Gas Supply	22		
Gas Pressure	23		
Gas Valve Replacement	23		

Hazard definitions

The following defined terms are used throughout this manual to bring attention to the presence of hazards of various risk levels or to important information concerning the life of the product.

 DANGER DANGER indicates an imminently hazardous situation which, if not avoided, will result in death or serious injury.

 WARNING WARNING indicates a potentially hazardous situation which, if not avoided, could result in death or serious injury.

 CAUTION CAUTION indicates a potentially hazardous situation which, if not avoided, may result in minor or moderate injury.

CAUTION CAUTION used without the safety alert symbol indicates a potentially hazardous situation which, if not avoided, may result in property damage.

NOTICE NOTICE indicates special instructions on installation, operation, or maintenance that are important but not related to personal injury or property damage.

Please read before proceeding

⚠ WARNING

Installer – Read all instructions, including this manual and the Outdoor Armor Water Heater Service Manual, before installing. Perform steps in the order given.

Have this water heater serviced/inspected by a qualified service technician, at least annually.

Failure to comply with the above could result in severe personal injury, death or substantial property damage.

NOTICE

When calling or writing about the water heater – Please have the water heater model and serial number from the water heater rating plate.

Consider piping and installation when determining water heater location.

Any claims for damage or shortage in shipment must be filed immediately against the transportation company by the consignee.

Factory warranty (shipped with unit) does not apply to units improperly installed or improperly operated.

⚠ WARNING

Failure to adhere to the guidelines on this page can result in severe personal injury, death, or substantial property damage.

⚠ WARNING

If the information in this manual is not followed exactly, a fire or explosion may result causing property damage, personal injury or loss of life.

-- This water heater **MUST NOT** be installed in any location where gasoline or flammable vapors are likely to be present.

-- **WHAT TO DO IF YOU SMELL GAS**

- Do not try to light any appliance near the water heater.
- Do not touch any electric switch.
- Immediately call your gas supplier. Follow the gas supplier's instructions.
- If you cannot reach your gas supplier, call the fire department.
- Installation and service must be performed by a qualified installer, service agency, or the gas supplier.

⚠ WARNING

DO NOT install units in rooms or environments that contain corrosive contaminants (see Table 1B on page 9). Failure to comply could result in severe personal injury, death, or substantial property damage.

When servicing the water heater –

- To avoid electric shock, disconnect electrical supply before performing maintenance.
- To avoid severe burns, allow the water heater to cool before performing maintenance.

Water heater operation –

- Do not block flow of combustion or ventilation air to the water heater.
- Should overheating occur or gas supply fail to shut off, do not turn off or disconnect electrical supply to circulator. Instead, shut off the gas supply at a location external to the appliance.
- Do not use this water heater if any part has been under water. The possible damage to a flooded appliance can be extensive and present numerous safety hazards. Any appliance that has been under water must be replaced.

The Outdoor Armor Water Heater - How it works...

1. **Stainless steel heat exchanger**
Allows water to flow through specially designed coils for maximum heat transfer, while providing protection against flue gas corrosion. The coils are encased in a jacket that contains the combustion process.
2. **Combustion chamber access cover**
Allows access to the combustion side of the heat exchanger coils.
3. **Blower**
The blower pulls in air and gas through the venturi (item 5). Air and gas mix inside the blower and are pushed into the burner, where they burn inside the combustion chamber.
4. **Gas valve**
The gas valve senses the negative pressure created by the blower, allowing gas to flow only if the gas valve is powered and combustion air is flowing.
5. **Venturi**
The venturi controls air and gas flow into the burner.
6. **Flue gas sensor (limit rated - not shown)**
This sensor monitors the flue gas exit temperature. The control module will modulate and shut down the water heater if the flue gas temperature gets too hot. This protects the flue pipe from overheating.
7. **Water heater outlet temperature sensor (housed with the high limit sensor)**
This sensor monitors water heater outlet water temperature.
8. **Water heater inlet temperature sensor**
This sensor monitors return water temperature. If the tank sensor is not connected, the control module will adjust the water heater firing rate so the inlet temperature is correct.
9. **Flow switch**
The flow switch is a safety device that ensures flow through the heat exchanger during operation. This appliance is low mass and should never be operated without flow. The flow switch makes contact when flow is detected and allows the unit to operate. If flow is discontinued during operation for any reason the flow switch will break the control circuit and the unit will shut down.
10. **Electronic LCD display**
The electronic display consists of 4 buttons, a navigation dial and a multiple line liquid crystal display.
11. **Burner (not shown)**
Made with metal fiber and stainless steel construction, the burner uses pre-mixed air and gas and provides a wide range of firing rates.
12. **Water outlet**
NPT water connection that supplies hot water to the tank.
13. **Water inlet**
NPT water connection that returns water from the tank to the heat exchanger.
14. **Gas connection pipe**
Threaded pipe connection. This pipe should be connected to the incoming gas supply for the purpose of delivering gas to the water heater.
15. **SMART SYSTEM Control Module**
The SMART SYSTEM Control responds to internal and external signals and controls the blower, gas valve, and pumps to meet the demand.
16. **Manual air vent**
Designed to remove trapped air from the heat exchanger coils.
17. **High voltage junction box**
The junction box contains the connection points for the line voltage power and the pump.
18. **Water heater drain port**
Location from which the heat exchanger can be drained.
19. **Low voltage connection board**
The connection board is used to connect external low voltage devices.
20. **Low voltage wiring connections (plugs)**
Conduit connection points for the low voltage connection board.
21. **Condensate drain connection**
Connects the condensate drain line to a 1/2" PVC union.
22. **Access cover - front (not shown)**
Provides access to the gas train and the heat exchanger.
23. **Ignition electrode**
Provides direct spark for igniting the burner.
24. **Flame inspection window**
The quartz glass window provides a view of the burner surface and flame.
25. **Gas shutoff valve**
Manual valve used to isolate the gas valve from the gas supply.
26. **High limit sensor (housed with the outlet temperature sensor)**
Device that monitors the outlet water temperature. If the temperature exceeds its setting, the integrated control will break the control circuit, shutting the water heater down.
27. **Relief valve**
Protects the heat exchanger from over pressure and temperature conditions. The relief valve is set at 150 PSI / 210°F.
28. **Flame sensor**
Used by the control module to detect the presence of burner flame.
29. **Line voltage wiring connections (plugs)**
Conduit connection points for the high voltage junction box.
30. **Top panel**
Removable panel to gain access to the internal components.
31. **Power switch**
Turns 120 VAC ON/OFF to the water heater.
32. **Leveling legs**
Used to allow the heat exchanger to be leveled. This is needed for the proper draining of the condensate from the combustion chamber.
33. **Air pressure switch**
The air pressure switch detects blocked inlet or outlet conditions.
34. **Pump relay (not shown)**
The pump relay is used to control the circulation pump.
35. **Transformer (not shown)**
The transformer provides 24V power to the integrated control.
36. **Gas shutoff switch (not shown)**
An electrical switch designed to cut power to the gas valve to prevent releasing any gas.
37. **Over-temp switch (Models 286 only) (located underneath vent cover - not shown)**
An electrical switch designed to shut down water heater operation in the event the outer back of the heat exchanger, directly above the flue connection exceeds 604°F (318°C). This is a one time switch and could warrant a heat exchanger replacement. Check the integrity of the rear refractory at the back of the upper coil if the switch opens.
38. **Vent / air cover**
Covers the over-temp switch and the flue collar with flue sensor.
39. **Air intake**
Provides combustion air to the appliance.
40. **Flue pipe assembly**
Factory supplied components for a complete venting system.
41. **Burner door temperature switch (Models 286 Only)**
An electrical switch designed to shut down water heater operation in the event the combustion chamber access cover exceeds 500°F (260°C). This switch may only be reset by a qualified service technician AFTER the underlying cause has been identified and corrected. Check the integrity of the front refractory on the inside of the combustion chamber access cover if the switch opens.

The Outdoor Armor Water Heater - How it works... *(continued)*

Models 201

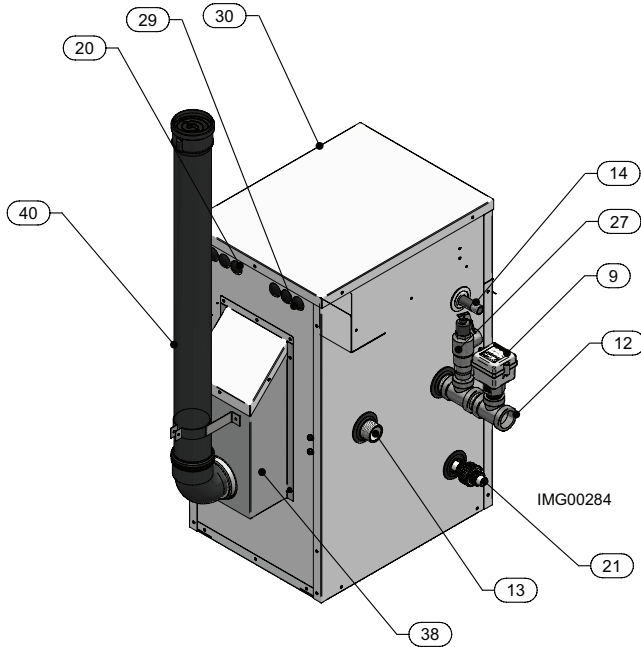

IMG00284

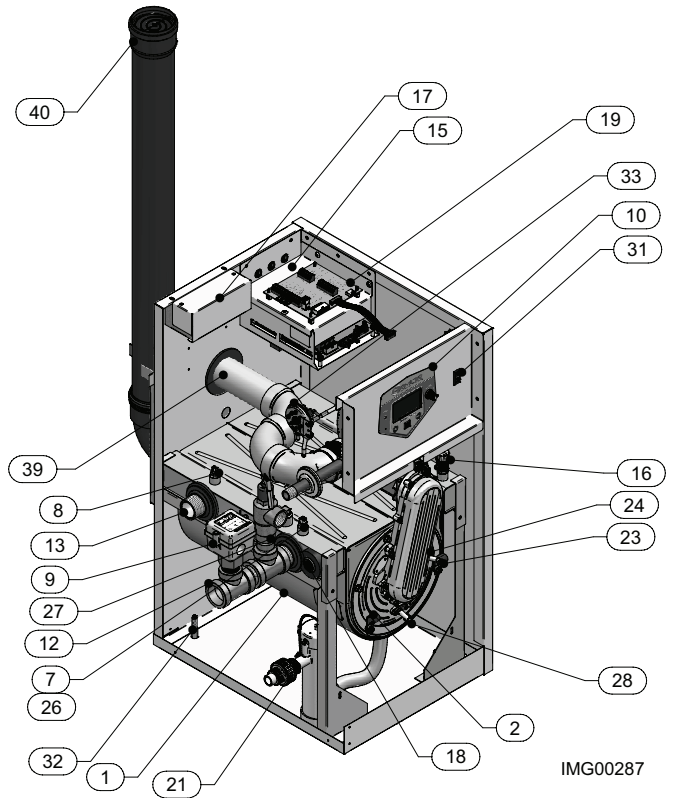

IMG00287

Rear View - Models 201

Left Side (inside unit) - Models 201

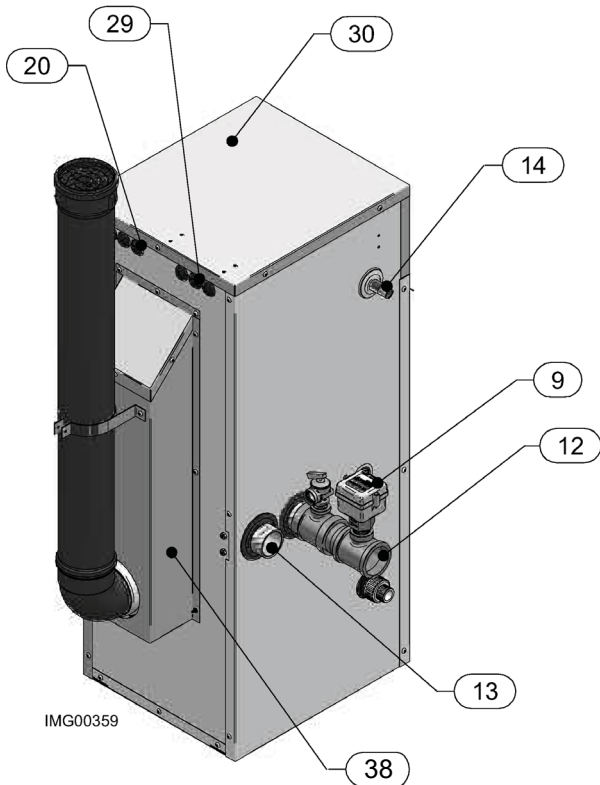

IMG00359

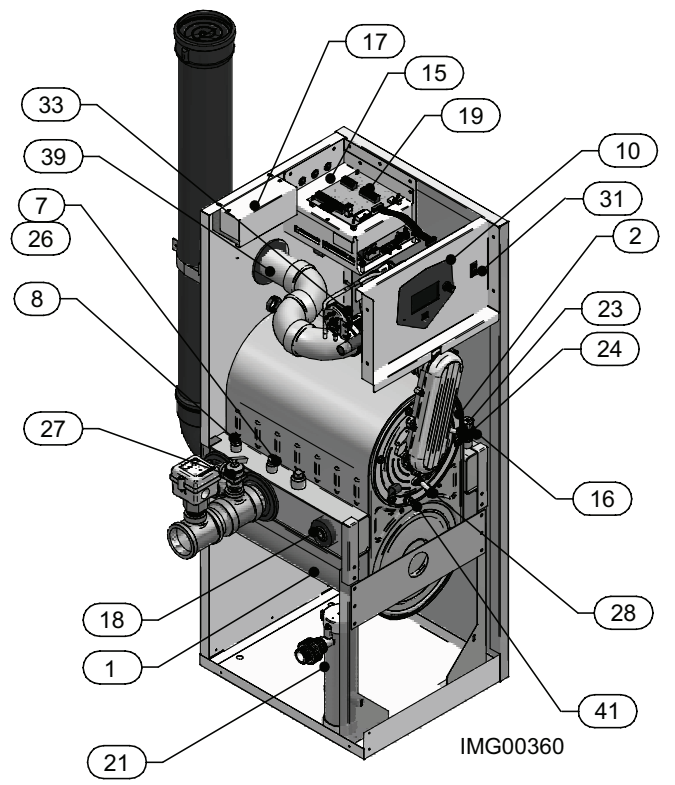

IMG00360

Rear View - Model 286

Left Side (inside unit) - Model 286

Ratings



HLW



LOW LEAD CONTENT

Model Number Note: Change "N" to "L" for L.P. gas models.	CSA Input Modulation Btu/hr	Water Content Gallons	Water Connections	Gas Connections
	(Note 2)			
OAN201PM	39,800 - 201,000	1.8	1-1/4"	1/2"
OAN286PM	57,000 - 285,000	2.5	2"	3/4"

NOTICE

Maximum allowed working pressure is located on the rating plate.

Notes:

- Outdoor Armor water heaters are supplied with special gas venting materials. Use only the method of installation specified in the Outdoor Armor Installation and Operation Manual.
- Standard outdoor Armor water heaters are equipped to operate from sea level to 4,500 feet **only** with no adjustments. The water heater will de-rate by 4% for each 1,000 feet above sea level up to 4,500 feet.
- The manual reset high limit provided with the outdoor water heater is listed to UL353. The auto reset high limit is listed to ANSI Z21.87.

1 Determine water heater location

Installation must comply with:

- Local, state, provincial, and national codes, laws, regulations, and ordinances.
- National Fuel Gas Code, ANSI Z223.1 – latest edition.
- National Electrical Code.

NOTICE

The outdoor Armor water heater gas manifold and controls met safe lighting and other performance under tests specified in ANSI Z21.10.3 – latest edition.

WARNING

Outdoor models must be installed outdoors only and must use the outdoor vent kit assembly supplied by the manufacturer. Personal injury or product damage may result if any other cap is used or if an outdoor model is used indoors. All covers, doors and jacket panels must be properly installed to ensure proper operation and prevent a hazardous situation.

CAUTION

This product contains a condensate management and disposal system that may be subject to freezing if exposed to sustained temperatures below 32°F. Precautions should be taken to protect the condensate trap and drain lines during extended periods of outdoor temperatures below 32°F. Consult the manufacturer (and see Table 1A below) for an optional condensate trap kit recommended for areas which may experience temperatures below 32°F. **Note:** This condensate option is only available for all models.

Table 1A - Ambient Temperature Requirements

Model	Kit Number	Minimum Allowable Ambient Temperature
OA 201	100157671	5°F
OK/OA 286	100157672	5°F

Before locating the water heater, check:

1. Check for nearby connection to:
 - Water piping
 - Gas supply piping
 - Electrical power
2. - Keep venting areas free of obstructions.
 - Keep area clean and free of combustible and flammable materials.
 - To avoid a blocked air inlet or blocked flue condition, keep the outdoor air inlet and flue outlet clear of leaves, debris, etc.

CAUTION

Do not install outdoor models directly on the ground. You must install the outdoor unit on a concrete, brick, block or pressure-treated wood platform.

CAUTION

Do not locate unit so that high winds can deflect off of adjacent walls, buildings or shrubbery causing recirculation. Recirculation of flue products may cause operational problems, bad combustion or damage to controls. Locate unit at least 3 feet (0.91m) from any wall or vertical surface to prevent wind conditions from affecting performance.

The outdoor unit must not be installed in an area that is enclosed by walls or a fence that will block free wind movement around the unit. Free movement of wind around the outdoor unit is required to carry away the flue products and provide combustion air. The flue outlet/combustion air inlet of an outdoor unit must not be installed closer than 10 feet from an inside corner of an L-shaped structure. Walls or enclosed fencing may cause eddy currents which can recirculate the flue products into the combustion air inlet. Recirculation of flue products may cause operational problems, bad combustion or non-warrantable damage to controls.

WARNING

- Do not install the outdoor unit under a deck.
- Do not install an outdoor unit in a well, stairwell, alcove, courtyard or other recessed area.
- Do not install outdoor units on stack frames.

Failure to comply with the above could result in severe personal injury, death or substantial property damage.

CAUTION

- Do not install outdoor units in locations where rain from building runoff drains will spill onto the unit.
- Do not locate the outdoor unit so that water from sprinklers may spray directly onto it. Water may damage controls or other electrical components.

3. Check area around the water heater. Remove any combustible materials, gasoline and other flammable liquids.

1 Determine water heater location *(continued)*

⚠ WARNING

Failure to keep the water heater area clear and free of combustible materials, gasoline and other flammable liquids and vapors can result in severe personal injury, death or substantial property damage.

4. If a new water heater will replace an existing water heater, check for and correct system leaks causing oxygen corrosion or heat exchanger cracks from hard water deposits.
5. Check around the water heater for any potential air contaminants that could risk corrosion to the water heater or the water heater combustion air supply (see Table 1B). Prevent combustion air contamination. Remove any of these contaminants from the water heater area.

⚠ WARNING

DO NOT install units in rooms or environments that contain corrosive contaminants (see Table 1B). Failure to comply could result in severe personal injury, death, or substantial property damage.

Provide clearances:

Clearances from combustible materials

1. Hot water pipes—at least 1/4" (6mm) from combustible materials.
2. Vent pipes—minimum of 14" (356mm) from the rear and 0" on the right side from combustible materials.

Clearances for service access

1. If you do not provide the minimum clearances, it may not be possible to service the water heater without removing it from the space.

Recommended service clearances:

Front	-	30" (762mm)
Top	-	24" (610mm)
Left side	-	24" (610mm)
Rear	-	24" (610mm)

Outdoor vent / air intake location

⚠ WARNING

The flue products discharged from the flue outlet on the outdoor vent may be very hot. Avoid touching or other direct contact with the flue gases or the vent termination assembly. These components are hot and direct contact can result in burns.

To prevent recirculation of the flue products into the combustion air inlet, follow all instructions in this section.

Flue gas condensate can condense on exterior walls or on the vent. Some discoloration to exterior building or unit surfaces can be expected. Adjacent brick or masonry surfaces should be protected with a rust resistant sheet metal plate.

Maintain a minimum of 24" (610mm) clearance to the side of the air inlet.

Locate the outdoor vent termination at least 48" (1.22m) below and 48" (1.22m) horizontally from any window, door, walkway or gravity air intake.

Locate outdoor unit at least 10 feet (3.05m) away from any forced air inlet.

Multiple outdoor unit installations require 24" (.61m) clearance between each vent termination.

Do not locate the terminations over public walkways.

Do not locate the terminations near soffit vents, crawl space vents, or other areas where condensate or vapor could create a nuisance, hazard, or cause property damage.

Do not locate the terminations where condensate vapor could cause damage or could be detrimental to the operation of regulators, relief valves, or other equipment.

Clearances around outdoor installations can change with time.

Do not allow the growth of trees, shrubs or other plants to obstruct the proper operation of the outdoor vent system.

Flooring and foundation

Flooring

The outdoor Armor water heater is approved for installation on combustible flooring.

⚠ WARNING

Do not install the water heater on carpeting even if foundation is used. Fire can result, causing severe personal injury, death, or substantial property damage.

Under no circumstances is the manufacturer to be held responsible for water damage in connection with this appliance, or any of its components. If flooding is possible, elevate the water heater sufficiently to prevent water from reaching the water heater.

1 Determine water heater location

Prevent combustion air contamination

Do not install in locations that can allow contamination of combustion air. Refer to Table 1B for products and areas which may cause contaminated combustion air.

Table 1B Corrosive Contaminants and Sources

Products to avoid:
Spray cans containing chloro/fluorocarbons
Permanent wave solutions
Chlorinated waxes/cleaners
Chlorine-based swimming pool chemicals
Calcium chloride used for thawing
Sodium chloride used for water softening
Refrigerant leaks
Paint or varnish removers
Hydrochloric acid/muriatic acid
Cements and glues
Antistatic fabric softeners used in clothes dryers
Chlorine-type bleaches, detergents, and cleaning solvents found in household laundry rooms
Adhesives used to fasten building products and other similar products
Areas likely to have contaminants
Dry cleaning/laundry areas and establishments
Swimming pools
Metal fabrication plants
Beauty shops
Refrigeration repair shops
Photo processing plants
Auto body shops
Plastic manufacturing plants
Furniture refinishing areas and establishments
New building construction
Remodeling areas
Garages with workshops

2 Prepare water heater

Remove water heater from wood pallet

1. After removing the outer shipping carton from the water heater, remove the installation kit.
2. Remove the front door to access the lag bolts in front of the unit (FIG. 2-1).
3. To remove the water heater from the pallet (after removing the front door):
 - a. Remove the two lag bolts from the wood pallet inside the water heater (FIG. 2-1).
 - b. Detach the water heater from the lag bolts in the rear of the unit, see FIG. 2-1.

NOTICE

Do not drop the water heater or bump the jacket on the floor or pallet. Damage to the water heater can result.

Figure 2-1 Water heater Mounted on Shipping Pallet

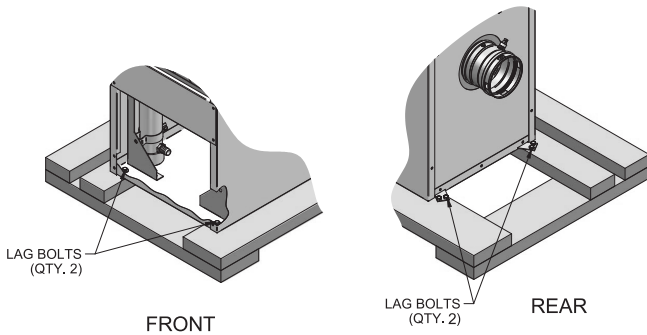

Install flue pipe assembly - (reference FIG. 2-2 for flue pipe assembly installation)

(reference FIG. 2-2 for flue pipe assembly installation)

This Category IV outdoor water heater is shipped with all the necessary vent components. Do not connect to any other flue or chimney. All components must be installed prior to operation. Basic steps are listed below to guide you through the installation of the flue pipe assembly provided with the unit.

1. Locate all venting components from the installation kit and carton.
2. Before connecting the vent pipe sections or components, verify the gasket is seated evenly inside the groove in the female end of the elbow and flue adapter.
3. Remove the factory provided screws from the vent/air cover and use them to install the wall strap.
4. Insert the elbow into the flue adapter.

CAUTION

Do not use grease or other lubricant on the vent seals. Only water may be used for this purpose. Grease or other lubricant can make the seal brittle or it can result in tears in the surface of the seal, this will result in flue gas leakage.

5. Slide the flue pipe through the wall strap and insert it into the elbow.
6. Install the bird screen into the top of the vent.

Figure 2-2 Install Flue Pipe Assembly

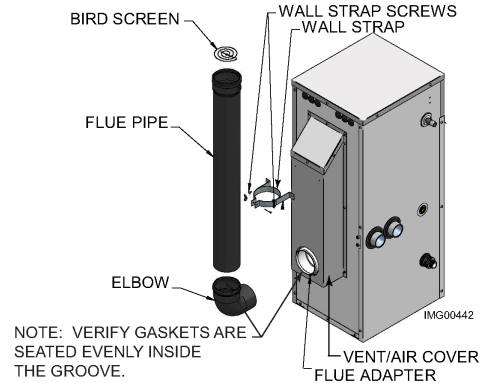

CAUTION

Do not use grease or other lubricant on the vent seals. Only water may be used for this purpose. Grease or other lubricant can make the seal brittle or it can result in tears in the surface of the seal, this will result in flue gas leakage.

7. Slide the flue pipe through the wall strap and insert it into the elbow, tighten clamp.
8. Install the bird screen into the top of the vent and tighten the clamp.

2 Prepare water heater

Gas conversions

⚠ WARNING For a water heater already installed, you must turn off gas supply, turn off power and allow the water heater to cool before proceeding. You must also completely test the water heater after conversion to verify performance as described under Start-up, Section 10 of this manual. Failure to comply could result in severe personal injury, death, or substantial property damage.

You must install a propane orifice to operate the outdoor water heater on propane gas. Verify when installing that the orifice size marking matches water heater size (Table 2A).

Table 2A LP Conversion Table

LP Conversion Table	
Model	LP Orifice Stamping
201	210 / W150
286	285

1. Remove the top and front access covers from the unit (Phillips screwdriver required for removal).
2. Remove the three screws securing the gas valve to the venturi (FIG. 2-3).
3. Locate the propane orifice disk from the conversion kit bag. Verify that the stamping on the orifice disk matches the water heater size (see Table 2A above).

Place the orifice into the black rubber grommet in the side of the gas valve and secure in the valve (FIG. 2-3).

4. Reposition the gas valve against the venturi and replace the screws (FIG. 2-3) securing the valve to the venturi.
5. After installation is complete, attach the propane conversion label (in the conversion kit bag) next to the water heater rating plate. Attach the LP caution label (in the conversion kit bag) to the left side of the unit in the lower left corner.
6. Replace the top and front access covers.

⚠ WARNING After converting to LP, check combustion per the Start-up procedure in Section 10 of this manual. Failure to check and verify combustion could result in severe personal injury, death, or substantial property damage.

Figure 2-3 Installing Propane Orifice

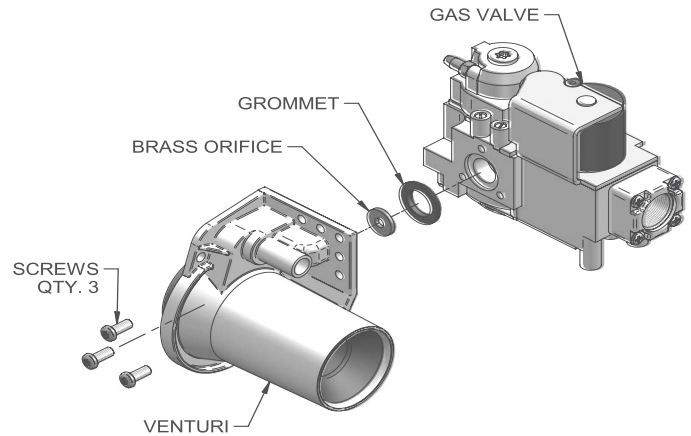

⚠ WARNING After converting to LP, check combustion per the Start-up procedure in Section 7 of this manual. Failure to check and verify combustion could result in severe personal injury, death, or substantial property damage.

Leveling the water heater

1. Set the water heater in place and check level.
 - a) Adjust legs if necessary to level the water heater, see FIG. 2-4 below.

Figure 2-4 Leveling Legs on the Water Heater

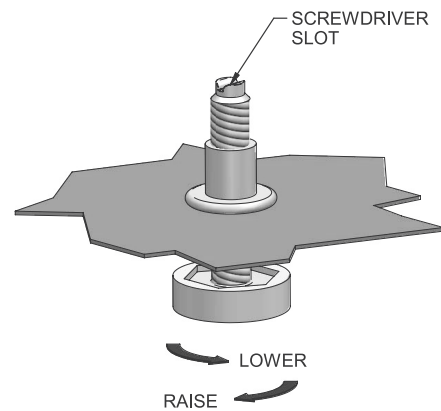

3 System piping

System water piping methods

Observe a minimum of 1/4 inch clearance around all un-insulated hot water pipes when openings around the pipes are not protected by non-combustible materials.

General piping information

Basic steps are listed below along with illustrations on the following pages (FIG.'s 3-5 thru 3-9), which will guide you through the installation of the outdoor water heater.

1. Connect the cold water supply to the inlet side of the water heater.
2. Connect the hot water supply to the outlet side of the water heater.
3. Install a backflow preventer on the cold feed make-up water line.
4. Install the factory supplied pump as shown in FIG.'s 3-5 thru 3-9. If pump is installed outdoors use pump cover, reference the *Pump Cover Installation* section on this page.
5. Install an expansion tank on the system supply. Consult the tank manufacturer's instruction for specific information relating to tank installation. Size the expansion tank for the required system volume and capacity.
6. Install a drain valve at the lowest point of the system.
7. This appliance is supplied with a relief valve sized in accordance with ASME Boiler and Pressure Vessel Code, Section IV ("Heating Boilers"). Pipe the discharge of the safety relief valve to a suitable drain to prevent injury in the event of pressure relief. Pipe the discharge to a drain. Provide piping that is the same size as the safety relief valve outlet. Never block the outlet of the safety relief valve.

Pump cover installation *reference FIG. 3-1 for pump cover installation)*

If the water heater was purchased with a pump, please follow the instructions below to install the pump and outdoor cover assembly. If a field supplied pump is used, ensure that it is installed per the manufacturer's specification in regard to indoor or outdoor location. An outdoor rated pump is recommended.

1. Locate the pump, pump cover assembly, flange kit and additional mounting nuts.
2. Before installing the pump, ensure the intended piping location allows room for the sheet metal cover assembly without interference.
3. Install the pump with the provided flanges and hardware.
4. Mount the pump cover base sheet metal aligning the holes for the piping and the bolts.
5. Using additional nuts, secure the sheet metal to the pump bolts.
6. Install the sheet metal top on the base with the provided screws (10x).

NOTICE

When connecting the unit to piping made of a different material, use of a dielectric fitting or a dielectric union conforming to ASSE 1079 is recommended to prevent corrosion and potential subsequent water leaks at or near the connection. Dielectric fittings may be required by local plumbing codes.

Figure 3-1 Pump Cover Installation

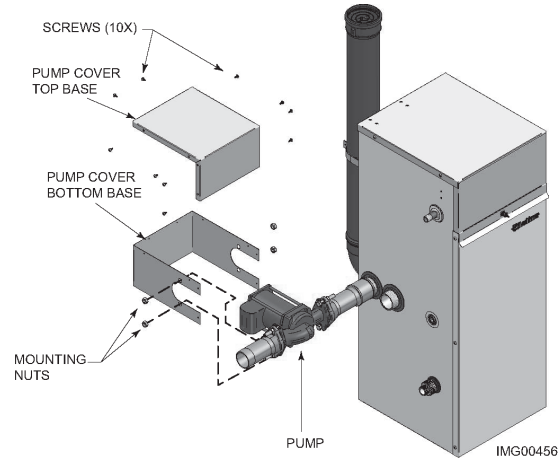

WARNING

The relief valve, tee and other necessary fittings are shipped in the install kit with the water heater and are to be field installed.

See the *piping illustrations included in this section, FIG.'s 3-5 thru 3-9 for suggested guidelines in piping the outdoor water heater.

NOTICE

*Please note that these illustrations are meant to show system piping concept only, the installer is responsible for all equipment and detailing required by local codes.

Flow switch and relief valve installation

Basic steps are listed below to guide you through the installation of the flow switch and relief valve provided with the unit.

1. Install the tee with the 3/4 inch fitting positioned vertically and on the top as shown in FIG. 3-2.
2. Install the relief valve into the 3/4 inch fitting of the tee installed in Step 1 (FIG. 3-2).
3. Install the close nipple on the downstream side of the temperature and pressure relief valve tee (FIG. 3-2).
4. Install the tee with the 1 inch fitting positioned vertically and on the top (FIG. 3-2).
5. Attach the paddle to the flow switch per the manufacturer's instructions. Reference Table 3A to select the correct paddle for the pipe size used (consult the manufacturer's instructions for a detailed explanation). **For Example:** If using a 1 1/4 inch pipe size (Models OAN201) select paddle #1.
6. Install the assembled flow switch into the 1 inch fitting of the tee installed in Step 4 (see FIG. 3-2).

NOTICE

Be sure to install flow switch so that the arrow on the flow switch is pointing in the direction of the flow (see FIG. 3-3).

3 System piping *(continued)*

Figure 3-2 Flow Switch and Relief Valve Installation

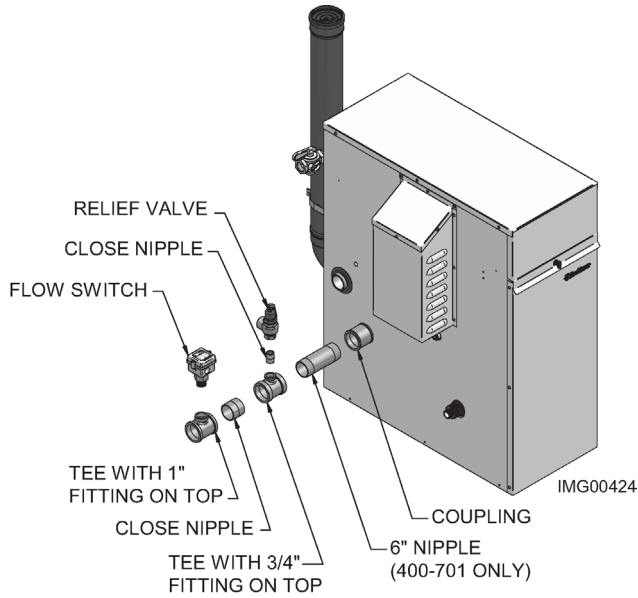

Flow switch adjustment

Refer to Table 3A for the proper setting of the sensitivity screw. For reference, the position of the screw prior to setting should be turned clockwise with a Phillips driver until it stops (FIG. 3-4). Proceed to turn the screw counterclockwise the amount of turns listed in Table 3A based on the model.

Consult the manufacturer's instructions for wiring the flow switch to your system.

Table 3A Paddle Size / Sensitivity Screw Adjustment

MODEL	PADDLE SIZE	SENSITIVITY SCREW ADJUSTMENT
Note: Paddles are included with the flow switch.		
201	#1	6 turns
286	#3	8¾ turns

NOTICE Turn the sensitivity screw clockwise to increase the flow rate required to activate the switch. Turn the sensitivity screw counterclockwise to decrease the flow rate required to activate the switch.

Figure 3-3 Flow Switch Adjustment

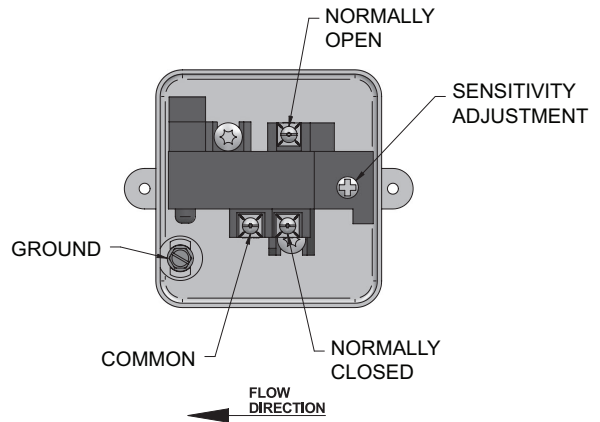

Scalding

This water heater can deliver scalding temperature water at any faucet in the system. Be careful whenever using hot water to avoid scalding injury. Certain appliances such as dishwashers and automatic clothes washers may require increased temperature water. By setting the thermostat on this water heater to obtain the increased temperature water required by these appliances, you may create the potential for scald injury. To protect against injury, you should install a mixing valve in the water system. This valve will reduce point of discharge temperature by mixing cold and hot water in branch supply lines. Such valves are available from the local plumbing supplier.

Figure 3-4 Scald Warning Label Located on the Appliance

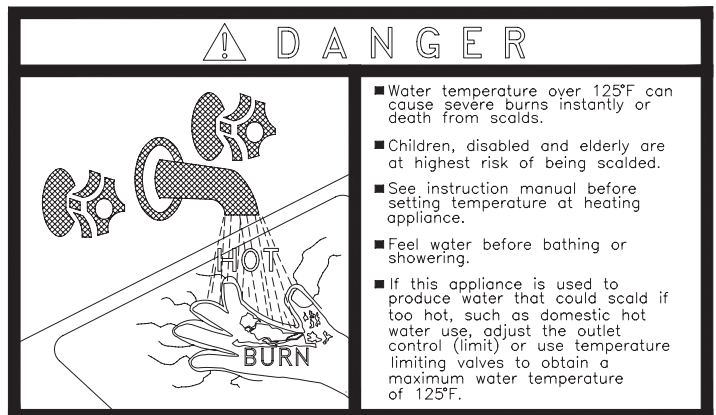

3 System piping

The following chart (Table 3B) details the relationship of water temperature and time with regard to scald injury and may be used as a guide in determining the safest water temperature for your applications.

Table 3B Approximate Time / Temperature Scald Chart

APPROXIMATE TIME / TEMPERATURE RELATIONSHIPS IN SCALDS	
120°F	More than 5 minutes
125°F	1 1/2 to 2 minutes
130°F	About 30 seconds
135°F	About 10 seconds
140°F	Less than 5 seconds
145°F	Less than 3 seconds
150°F	About 1 1/2 seconds
155°F	About 1 second

Water chemistry

NOTICE

The temperature rises and circulating pumps shown in Table 3C are selected based on the heating of potable water with a specified water chemistry. See Table 7A in Start-Up Section for recommendations.

Heating of high hardness and/or high total dissolved solids water may require a larger circulating pump, and a revised temperature rise specification based on the water chemistry of the water to be heated. See Table 7A in Start-Up Section for recommendations.

Water with a hardness of less than 5 grains per gallon will usually have a pH which can be aggressive and corrosive causing non-warrantable damage to the pump, and associated piping. Corrosion due to water chemistry generally shows up first in the hot water system because heated water increases the rate of corrosive chemical reactions.

Piping components

Water heater system piping:

Water heater system piping **MUST** be sized per the pipe requirements listed in FIG.'s 3-8 and 3-9. Reducing the pipe size can restrict the flow rate through the water heater, causing inadvertent high limit shutdowns and poor system performance.

Check valves:

Field supplied. Check valves are recommended for installation as shown in FIG.'s 3-5 thru 3-19.

Water heater isolation valves:

Field supplied. Full port ball valves are required. Failure to use full port ball valves could result in a restricted flow rate through the water heater.

Anti-scald mixing valve:

Field supplied. An anti-scald mixing valve is recommended when storing domestic hot water above 115°F.

Unions:

Field supplied. Recommended for unit serviceability.

Temperature and pressure relief valve:

Factory supplied on water heaters. The temperature and pressure relief valve is sized to ASME specifications. Storage tanks may require additional valves depending on local codes.

Tank sensor:

Lochinvar supplies a tank sensor. The tank sensor must be installed in the tapping provided in the lower 25% of the storage tank to achieve proper operation. As shipped from the factory, the tank sensor is in the literature package shipped with the unit. Placing the sensor in the tapping provided on the storage tank will improve temperature response and prevent short cycles of operation.

Strainer:

Field supplied. Required to help eliminate debris from causing damage to the heat exchanger. When installing in a pre-existing system, it is recommended to install a filter in the recirculation line capable of removing debris left in the system.

Building Recirculation Filter:

Field supplied as required (see Table 7A). When required, helps to eliminate debris from causing damage to the heat exchanger.

CAUTION

Check recirculation pump size to verify it is sized for filter addition and upsize if necessary.

Table 3C Water Heater Pump Applications / Typical Temperature Rise

Water Heater Pump Applications						
Model	*Pipe Size	Water Hardness	Grundfos	Flow Rate (GPM)	Loss (FT/HD)	Temp. Rise
201	1-1/4"	5 to 12 gpg	*UP 43-100 SF	21	22	18°F
		12 to 15 gpg	TP 40-160	28	38	13°F
286	2"	5 to 12 gpg	*UP 43-100 SF	30	23	18°F
		12 to 15 gpg	TP 40-160	38	36	14°F

*Denotes standard pump supplied with unit.

NOTICE

Pump selections and flow shown in Table 3C are based on 45 feet of piping, 4 - 90° elbows, and 2 - fully ported ball valves.

3 System piping *(continued)*

Figure 3-5 Single Heater - Single Tank

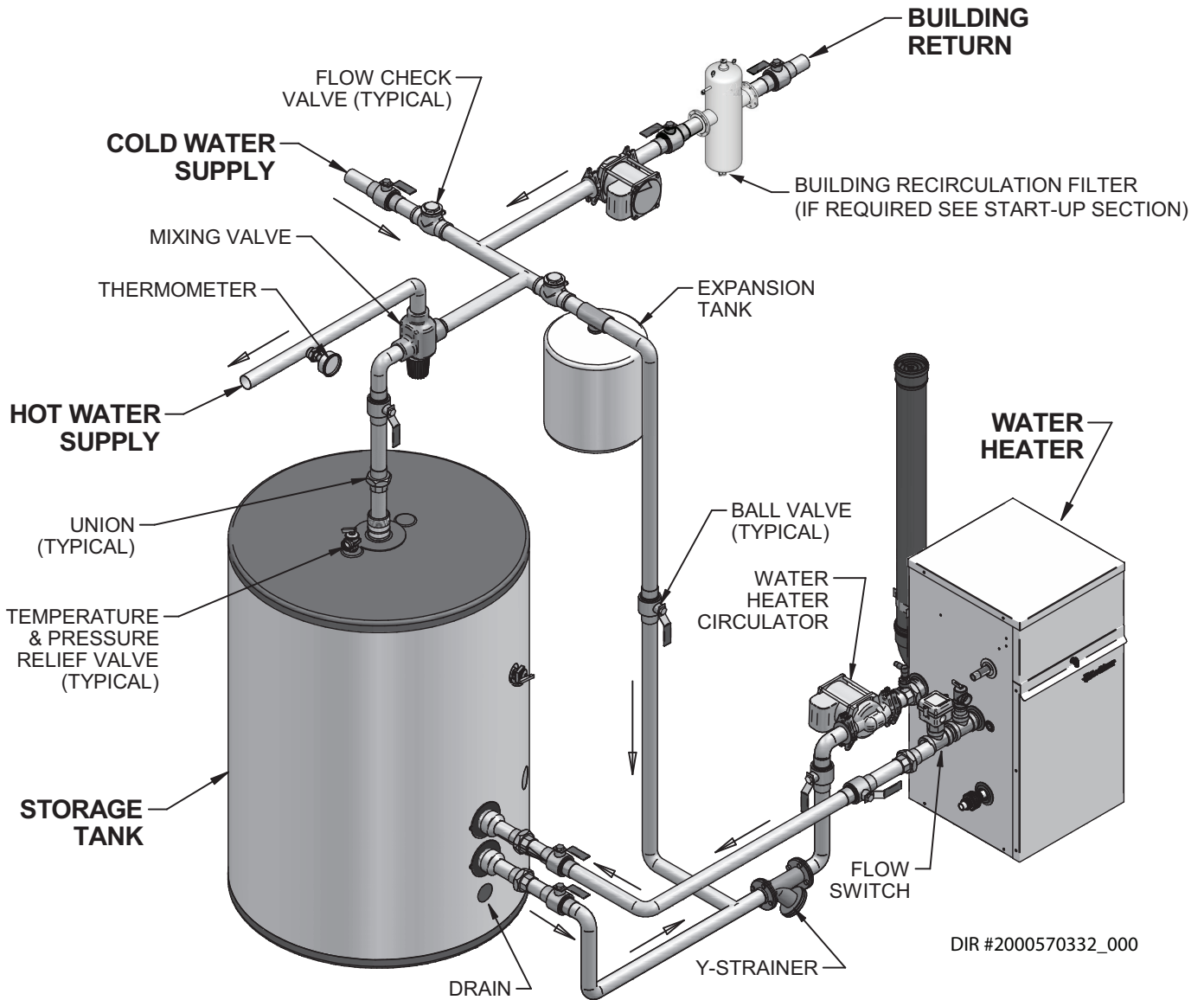

CAUTION

The piping will not support the weight of the water heater circulator pump. Do not attempt to support the weight of the water heater circulator pump with the piping or its accessories. Refer to the pump manufacturer's installation instructions. Failure to comply could result in severe personal injury, death, or substantial property damage.

NOTICE

Please note that these illustrations are meant to show system piping concept only, the installer is responsible for all equipment. The installer must follow all manufacturer's instructions for each system component. The installer is responsible for compliance with local codes.

Indoor tank shown for illustration purposes.

3 System piping

Figure 3-6 Single Heater - Single Tank (2 Temperature)

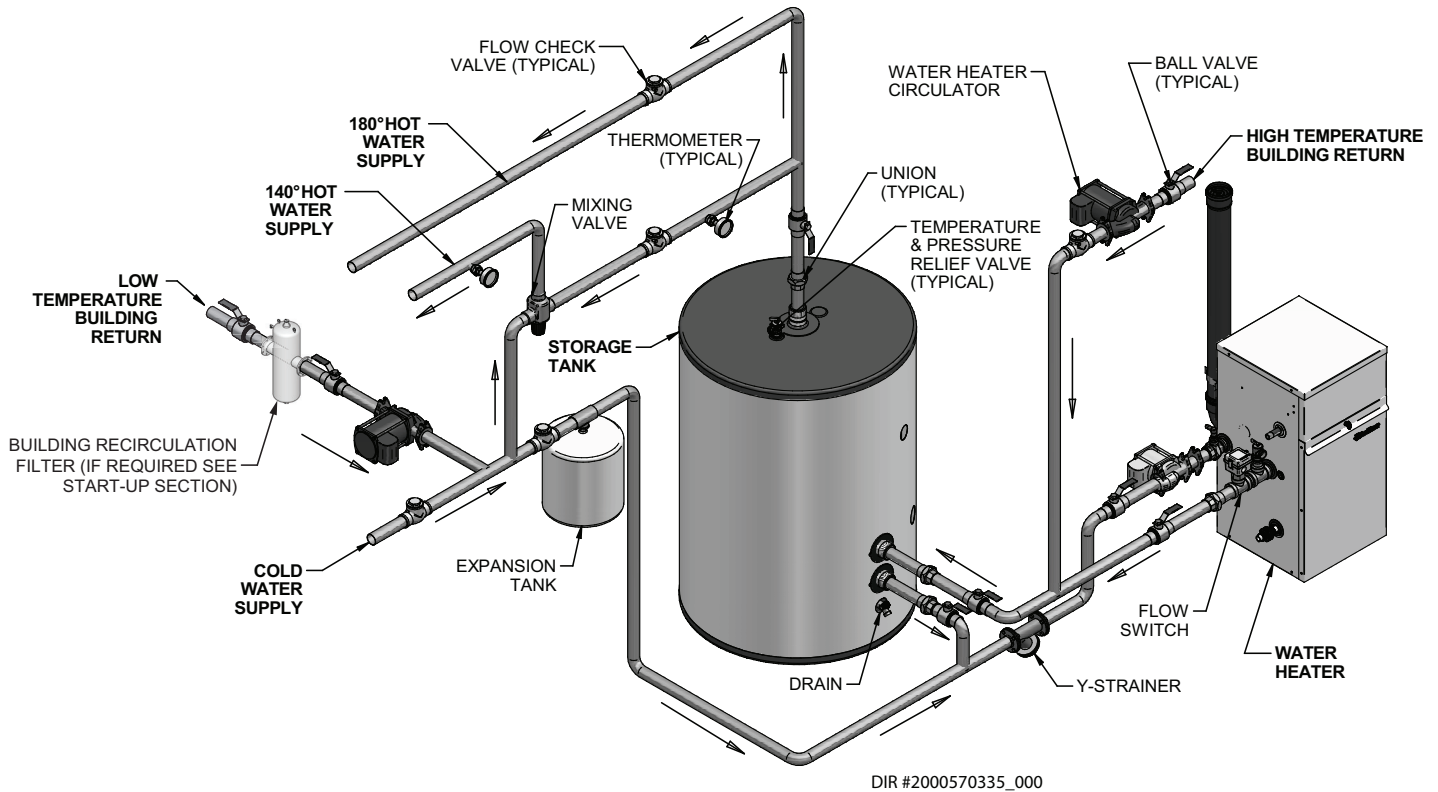

CAUTION The piping will not support the weight of the water heater circulator pump. Do not attempt to support the weight of the water heater circulator pump with the piping or its accessories. Refer to the pump manufacturer’s installation instructions. Failure to comply could result in severe personal injury, death, or substantial property damage.

NOTICE Please note that these illustrations are meant to show system piping concept only, the installer is responsible for all equipment. The installer must follow all manufacturer’s instructions for each system component. The installer is responsible for compliance with local codes.

Indoor tank shown for illustration purposes.

3 System piping *(continued)*

Figure 3-7 Single Heater - Double Tank

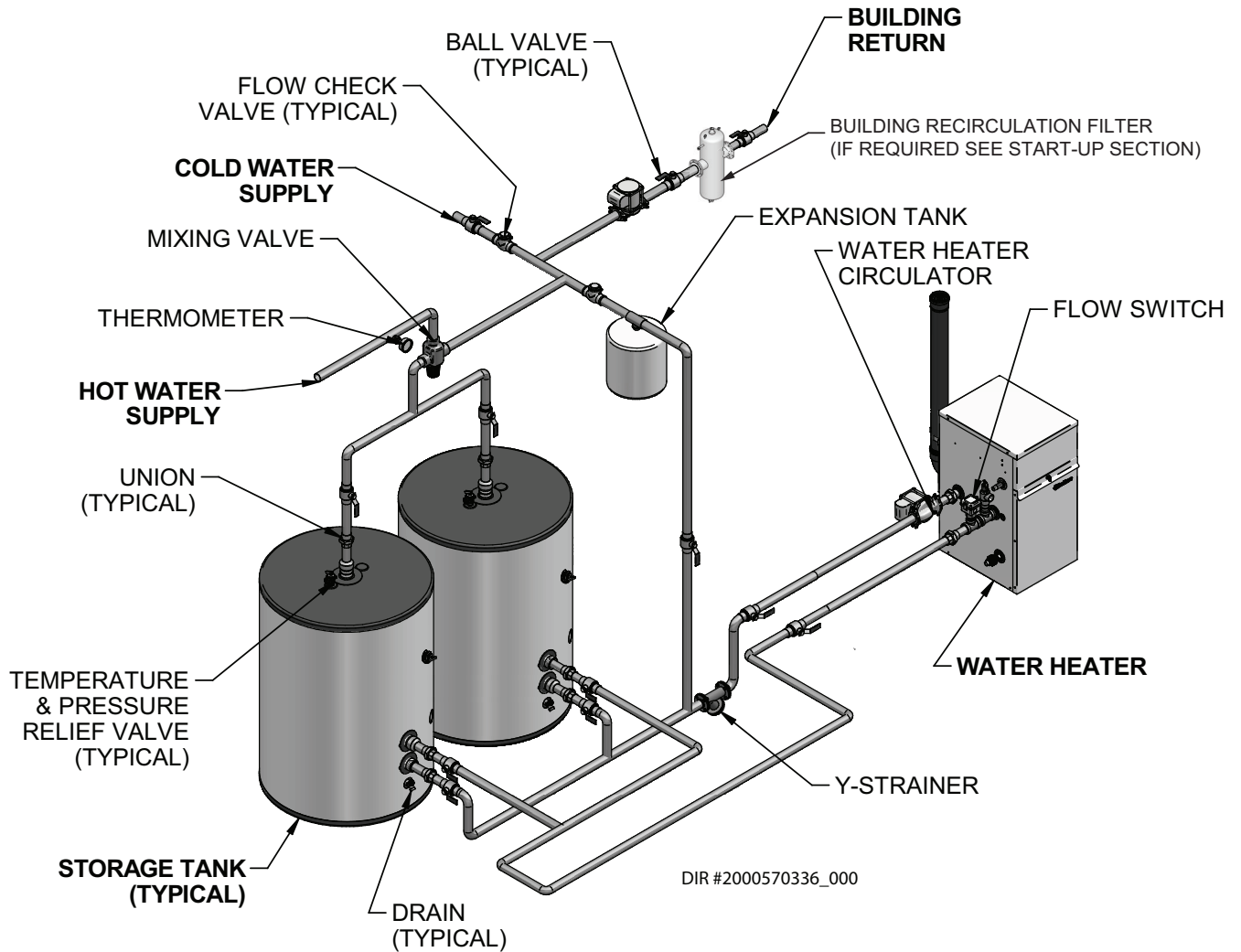

CAUTION The piping will not support the weight of the water heater circulator pump. Do not attempt to support the weight of the water heater circulator pump with the piping or its accessories. Refer to the pump manufacturer’s installation instructions. Failure to comply could result in severe personal injury, death, or substantial property damage.

NOTICE Please note that these illustrations are meant to show system piping concept only, the installer is responsible for all equipment. The installer must follow all manufacturer’s instructions for each system component. The installer is responsible for compliance with local codes.

Indoor tank shown for illustration purposes.

3 System piping

Figure 3-8 Double Heater - Single Tank

Model	Number of Units							Model	Number of Units						
	2	3	4	5	6	7	8		2	3	4	5	6	7	8
	Required Pipe Sizes in NPT with Standard Pump								Required Pipe Sizes in NPT with Upsized Pump						
201	2"	2"	2 1/2"	2 1/2"	3"	3"	4"	201	2"	2 1/2"	3"	3"	4"	4"	4"
286	2"	2 1/2"	3"	3"	4"	4"	4"	286	2 1/2"	3"	3"	4"	4"	4"	5"

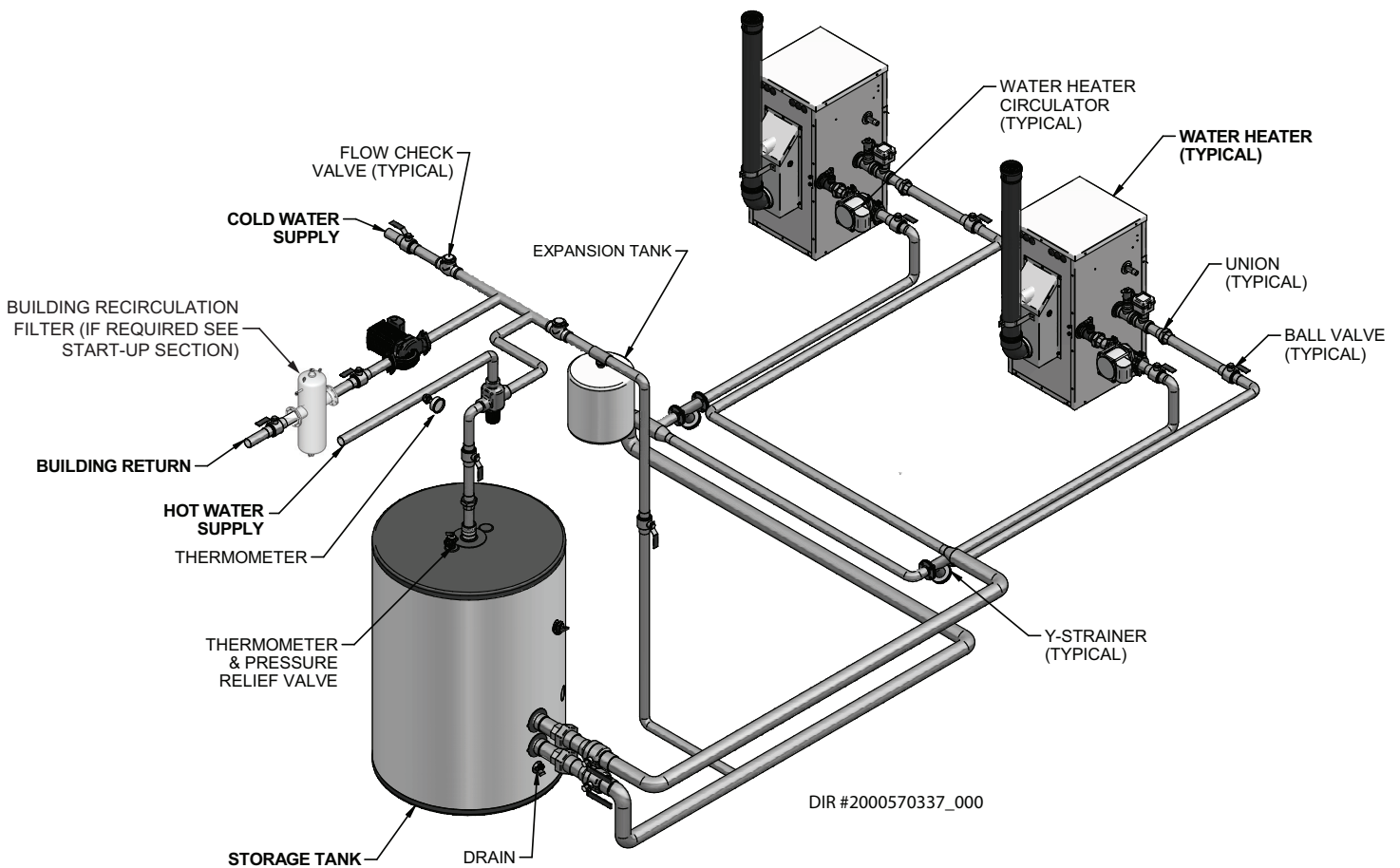

CAUTION

The piping will not support the weight of the water heater circulator pump. Do not attempt to support the weight of the water heater circulator pump with the piping or its accessories. Refer to the pump manufacturer's installation instructions. Failure to comply could result in severe personal injury, death, or substantial property damage.

NOTICE

Please note that these illustrations are meant to show system piping concept only, the installer is responsible for all equipment. The installer must follow all manufacturer's instructions for each system component. The installer is responsible for compliance with local codes.

Indoor tank shown for illustration purposes.

3 System piping *(continued)*

Figure 3-9 Double Heater - Double Tank

Model	Number of Units							Model	Number of Units						
	2	3	4	5	6	7	8		2	3	4	5	6	7	8
	Required Pipe Sizes in NPT with Standard Pump								Required Pipe Sizes in NPT with Upsized Pump						
201	2"	2"	2 1/2"	2 1/2"	3"	3"	4"	201	2"	2 1/2"	3"	3"	4"	4"	4"
286	2"	2 1/2"	3"	3"	4"	4"	4"	286	2 1/2"	3"	3"	4"	4"	4"	5"

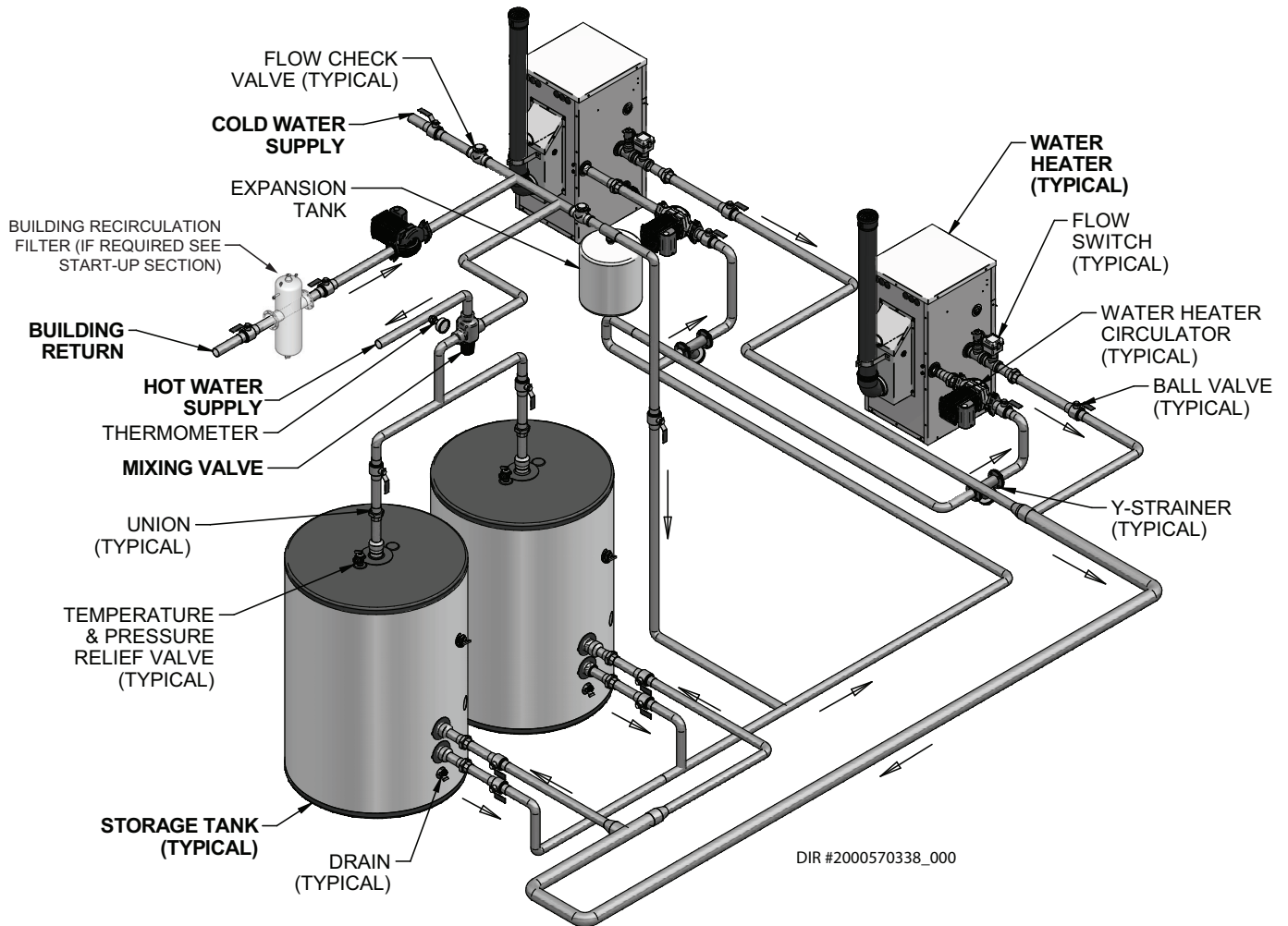

DIR #2000570338_000

CAUTION The piping will not support the weight of the water heater circulator pump. Do not attempt to support the weight of the water heater circulator pump with the piping or its accessories. Refer to the pump manufacturer’s installation instructions. Failure to comply could result in severe personal injury, death, or substantial property damage.

NOTICE Please note that these illustrations are meant to show system piping concept only, the installer is responsible for all equipment. The installer must follow all manufacturer’s instructions for each system component. The installer is responsible for compliance with local codes.

Indoor tank shown for illustration purposes.

4 Gas connections

Connecting gas supply piping

1. Remove the top access panel and refer to FIG.'s 4-1 and 4-2 to pipe gas to the water heater.
 - a. Install ground joint union for servicing, when required.
 - b. Install a manual shutoff valve in the gas supply piping outside water heater jacket when required by local codes or utility requirements.
2. Install sediment trap / drip leg.

Figure 4-1 Gas Supply Piping - Models 201

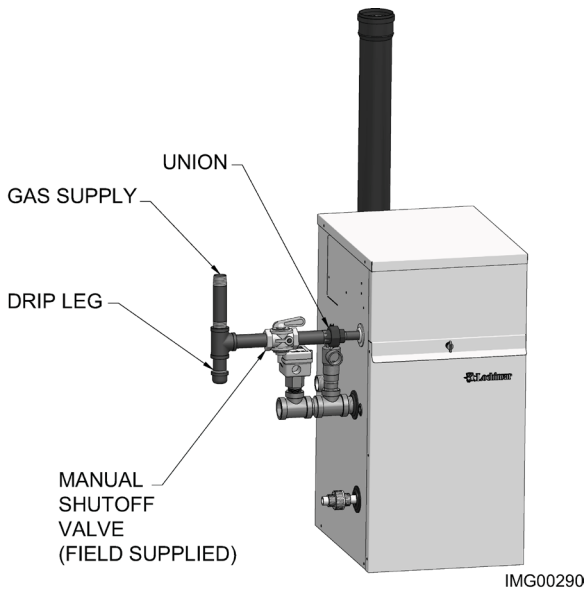

IMG00290

Figure 4-2 Gas Supply Piping - Models 286

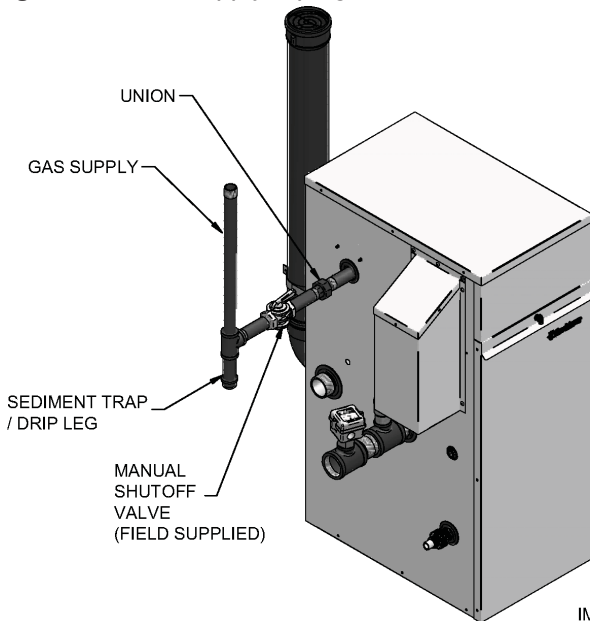

IMG00397

3. Support piping with hangers, not by the water heater or its accessories.

WARNING The gas valve and blower will not support the weight of the piping. Do not attempt to support the weight of the piping with the water heater or its accessories. Failure to comply could result in severe personal injury, death, or substantial property damage.

4. Purge all air from the gas supply piping.
5. Before placing the water heater in operation, check the water heater and its gas connection for leaks.
 - a. The appliance must be disconnected from the gas supply piping system during any pressure testing of that system at a test pressure in excess of 1/2 PSIG (3.5 kPa).
 - b. The appliance must be isolated from the gas supply piping system by closing a manual shutoff valve during any pressure testing of the gas supply piping system at test pressures equal to or less than 1/2 PSIG (3.5 kPa).
 - c. The appliance and its gas connection must be leak tested before placing it in operation.

WARNING Do not check for gas leaks with an open flame – use the bubble test. Failure to use the bubble test or check for gas leaks can cause severe personal injury, death, or substantial property damage.

6. Use pipe sealing compound compatible with propane gases. Apply sparingly only to male threads of the pipe joints so that pipe dope does not block gas flow.

WARNING Failure to apply pipe sealing compound as detailed in this manual can result in severe personal injury, death, or substantial property damage.

WARNING Outdoor Armor water heaters are typically shipped ready to fire on natural gas. Check the water heater rating plate to determine which fuel the water heater is set for. If set to natural gas, it may be converted to LP by installing an orifice or by making a gas valve adjustment (see pages 12 and 13). In order to operate on LP gas, an orifice **MUST BE** installed or a gas valve adjustment **MUST BE** made. Failure to comply could result in severe personal injury, death, or substantial property damage.

4 Gas connections *(continued)*

WARNING

Use two wrenches when tightening gas piping at water heater (FIG. 4-3), using one wrench to prevent the water heater gas line connection from turning. Failure to support the water heater gas connection pipe to prevent it from turning could damage gas line components.

Figure 4-3 Inlet Pipe with Backup Wrench

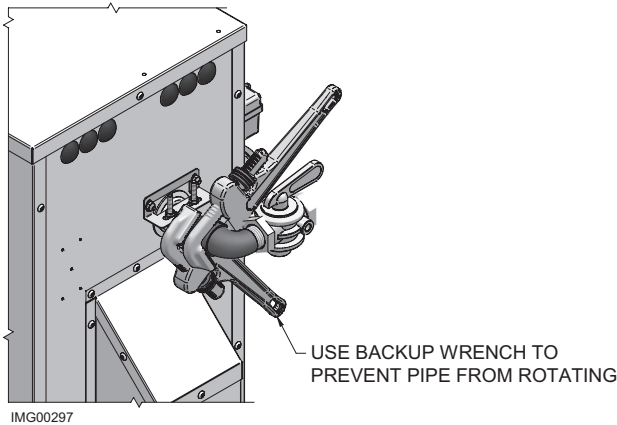

NOTICE

Maximum inlet gas pressure must not exceed the value specified. Minimum value listed is for the purposes of input adjustment.

Natural gas:

Pipe sizing for natural gas

1. Refer to Table 4A for pipe length and diameter. Based on rated water heater input (divide by 1,000 to obtain cubic feet per hour).
 - a. Table 4A is only for natural gas with specific gravity 0.60 inches, with a pressure drop through the gas piping of 0.30 inches w.c.
 - b. For additional gas pipe sizing information, refer to ANSI Z223.1 (or B149.1 for Canadian installations).

Natural gas supply pressure requirements

1. Pressure required at the gas valve inlet pressure port:
 - Maximum 14 inches w.c. with no flow (lockup) or with water heater on.
 - Minimum 4 inches w.c. with gas flowing (verify during water heater startup).
2. Install 100% lockup gas pressure regulator in supply line if inlet pressure can exceed 14 inches w.c. at any time. Adjust lockup regulator for 14 inches w.c. maximum.

Propane gas:

WARNING

Outdoor Armor water heaters are typically shipped ready to fire on natural gas. Check water heater rating plate to determine which fuel the water heater is set for. If set to natural gas, it may be converted to LP by installing an orifice or by making a gas valve adjustment (see pages 11 and 12). In order to operate on LP gas, an orifice **MUST BE** installed or a gas valve adjustment **MUST BE** made. Failure to comply could result in severe personal injury, death, or substantial property damage.

Pipe sizing for propane gas

1. Contact gas supplier to size pipes, tanks, and 100% lockup gas pressure regulator.

Propane supply pressure requirements

1. Adjust propane supply regulator provided by the gas supplier for 14 inches w.c. maximum pressure.
2. Pressure required at gas valve inlet pressure port:
 - Maximum 14 inches w.c. with no flow (lockup) or with water heater on.
 - Minimum 8 inches w.c. with gas flowing (verify during water heater startup).

WARNING

Ensure that the high gas pressure regulator is at least 6 - 10 feet upstream of the appliance.

4 Gas connections

Table 4A Natural Gas Pipe Size Chart

Capacity of Schedule 40 Metallic Pipe in Cubic Feet of Natural Gas Per Hour (based on .60 specific gravity, 0.30" w.c. pressure drop)														
Pipe Size (Inches)	Length of Pipe in Straight Feet													
	10	20	30	40	50	60	70	80	90	100	125	150	175	200/201
1/2	131	90	72	62	55	N/A	N/A	N/A	N/A	N/A	N/A	N/A	N/A	N/A
3/4	273	188	151	129	114	104	95	89	83	79	70	63	58	N/A
1	514	353	284	243	215	195	179	167	157	148	131	119	109	102
1 1/4	1,060	726	583	499	442	400	368	343	322	304	269	244	224	209
1 1/2	1,580	1,090	873	747	662	600	552	514	482	455	403	366	336	313
2	3,050	2,090	1,680	1,440	1,280	1,160	1,060	989	928	877	777	704	648	602
2 1/2	4,860	3,340	2,680	2,290	2,030	1,840	1,690	1,580	1,480	1,400	1,240	1,120	1,030	960
3	8,580	5,900	4,740	4,050	3,590	3,260	3,000	2,790	2,610	2,470	2,190	1,980	1,820	1,700
4	17,500	12,000	9,660	8,270	7,330	6,640	6,110	5,680	5,330	5,040	4,460	4,050	3,720	3,460

⚠ WARNING

Outdoor Armor water heaters are typically shipped ready to fire on natural gas. Check the water heater rating plate to determine which fuel the water heater is set for. If set to natural gas, it may be converted to LP by installing an orifice or by making a gas valve adjustment (see pages 11 and 12). In order to operate on LP gas, an orifice **MUST BE** installed or a gas valve adjustment **MUST BE** made. Failure to comply could result in severe personal injury, death, or substantial property damage.

Check inlet gas supply

NOTICE

CSA or UL listed flexible gas connections are acceptable, but you must exercise caution to ensure that the line has adequate capacity to allow your water heater to fire at full rate. Consult with local codes for proper installation or service procedures.

⚠ WARNING

DO NOT adjust or attempt to measure gas valve outlet pressure. The gas valve is factory-set for the correct outlet pressure. This setting is suitable for natural gas and propane, requiring no field adjustment. Attempting to alter or measure the gas valve outlet pressure could result in damage to the valve, causing potential severe personal injury, death, or substantial property damage.

The gas piping must be sized for the proper flow and length of pipe, to avoid excessive pressure drop. Both the gas meter and the gas regulator must be properly sized for the total gas load.

If you experience a pressure drop greater than 1 inch w.c., the meter, regulator, or gas line is undersized or in need of service. Perform the steps below when checking inlet gas supply:

1. Turn the main power switch to the "OFF" position.
2. Shut off gas supply at the manual gas valve in the gas piping to the appliance.
3. Loosen the set screw one (1) full turn from inside the pressure tap on top of the gas valve. Install a suitable 1/8" (3 mm) fitting (field supplied) for the manometer tubing. Place the tubing of the manometer over the tap once the set screw is loosened or the 1/8" (3 mm) fitting is installed (depending on model) as shown in FIG. 4-4 on page 23.
4. Slowly turn on the gas supply at the field installed manual gas valve.

5. Turn the power switch to the "ON" position.
6. Adjust the temperature set point on the control panel of the SMART SYSTEM control module to call for heat.
7. Observe the gas supply pressure as the burner fires at 100% of rated input. Percent of burner input will be displayed on the control panel.
8. Ensure inlet pressure is within specified range. Minimum and maximum gas supply pressures are specified in this section of the manual.
9. If gas supply pressure is within normal range and no adjustments are needed, proceed on to Step 11.
10. If the gas pressure is out of range, contact the gas utility, gas supplier, qualified installer or service agency to determine the necessary steps to provide proper gas pressure to the control.
11. Turn the power switch to the "OFF" position.
12. Shut off the gas supply at the manual gas valve in the gas piping to the appliance.
13. Remove the manometer from the pressure tap on top of the gas valve. Re-tighten the set screw inside the pressure tap.

⚠ WARNING

When re-tightening the set screw, be sure to tighten securely to prevent gas leaks.

Do not check for gas leaks with an open flame -- use the bubble test. Failure to use the bubble test or check for gas leaks can cause severe personal injury, death, or substantial property damage.

14. Turn on the gas supply at the manual gas valve.
15. Turn the power switch to the "ON" position.
16. Adjust the temperature set point on the control panel of the SMART SYSTEM control module to the desired water temperature so the appliance will call for heat.

4 Gas connections *(continued)*

- Check burner performance by cycling the system while you observe burner response. The burner should ignite promptly. Flame pattern should be stable. Turn system off and allow burner to cool, then cycle burner again to ensure proper ignition and flame characteristics.

Figure 4-4 Inlet Gas Supply Check

LOOSEN THE SET SCREW ONE(1) FULL TURN AND PLACE THE MANOMETER TUBING OVER THE PRESSURE TAP

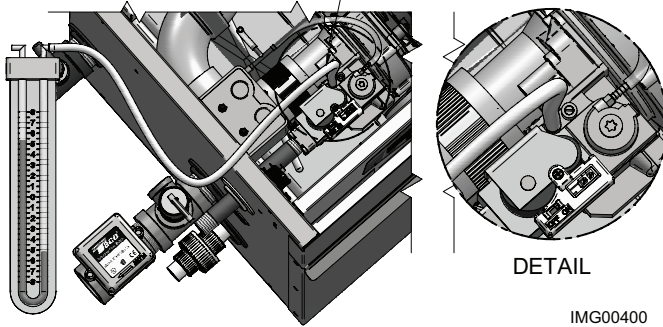

Gas pressure

The gas pressure must remain between 4 inches w.c. (natural), 8 inches w.c. (LP) minimum and 14 inches w.c. (natural and LP) maximum during stand-by (static) mode and while in operating (dynamic) mode. If an in-line regulator is used, it must be a minimum of 10 feet from the outdoor water heater. It is very important that the gas line is properly purged by the gas supplier or utility company. Failure to properly purge the lines or improper line sizing, will result in ignition failure.

The problem is especially noticeable in NEW LP installations and also in empty tank situations. This can also occur when a utility company shuts off service to an area to provide maintenance to their lines.

Gas valve replacement

The gas valve **MUST NOT** be replaced with a conventional gas valve under any circumstances. As an additional safety feature, this gas valve has a flanged connection to the venturi and blower.

WARNING Failure to follow all precautions could result in fire, explosion, or death!

WARNING DO NOT adjust gas valve outlet pressure. The gas valve is factory-set for the correct outlet pressure. This setting is suitable for natural gas and propane, requiring no field adjustment. Attempting to alter the gas valve outlet pressure could result in damage to the valve, causing potential severe personal injury, death, or substantial property damage.

5 Field wiring

⚠ WARNING ELECTRICAL SHOCK HAZARD – For your safety, turn off electrical power supply before making any electrical connections to avoid possible electric shock hazard. Failure to do so can cause severe personal injury or death.

NOTICE Wiring must be N.E.C. Class 1.

If original wiring as supplied with the water heater must be replaced, use only 105°C wire or equivalent.

The water heater must be electrically grounded as required by National Electrical Code ANSI/NFPA 70 – latest edition.

All wiring exterior to the appliance must be enclosed in approved conduit.

⚠ CAUTION Label all wires prior to disconnection when servicing controls. Wiring errors can cause improper and dangerous operation.

Figure 5-1 Line Voltage Field Wiring Connections - With and Without Contactor

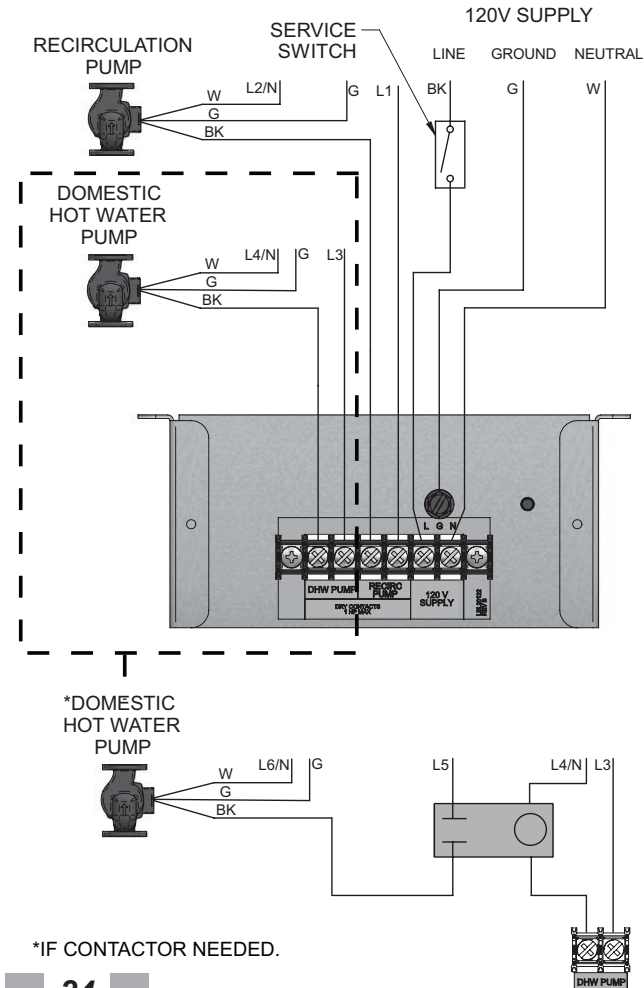

Installation must comply with:

1. National Electrical Code and any other national, state, provincial, or local codes, or regulations.

Line voltage connections

1. Connect 120 VAC power wiring to the line voltage terminal strip in the junction box, as shown in FIG. 5-1.
2. Provide and install a fused disconnect or service switch (15 amp recommended) as required by the code (see FIG. 5-1).
3. The DHW (water heater) pump is shipped loose on all Armor models. Wire the water heater pump as shown in FIG. 5-1.
4. The outdoor water heater is capable of controlling a building recirculation pump (field supplied). Wire the building recirculation pump as shown in FIG. 5-1.
5. Dry contacts are sized for 1 hp/120V or 2 hp/240V.

⚠ CAUTION If using a pump greater than these ratings, a field supplied contactor must be installed. If not installed, electrical failures and unexpected operation may occur. See FIG. 5-1 for wiring information.

Low voltage connections

1. Route all low voltage wires through the knockouts in the rear of the water heater, as shown in FIG. 5-2.
2. Connect low voltage wiring to low voltage connection board as shown in FIG. 5-3 on page 27 of this manual and the water heater wiring diagram.

Figure 5-2 Routing Field Wiring

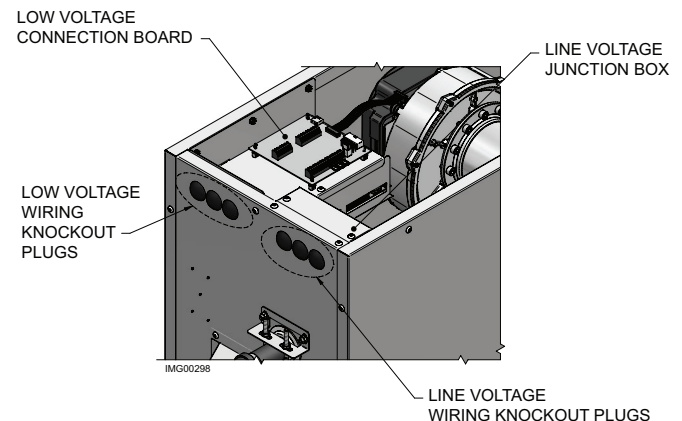

5 Field wiring *(continued)*

Tank thermostat

1. Connect the tank thermostats (isolated contact only) to the tank thermostat contacts as shown in FIG. 5-3.

Tank sensor

1. By installing a tank sensor, the SMART SYSTEM control can perform the tank thermostat function. The SMART SYSTEM control automatically detects the presence of this sensor and generates a DHW call for heat when the tank temperature drops below the programmed differential and finishes the call for heat when the tank temperature reaches above the programmed offset.
2. The tank sensor is the only sensor suitable for use with the SMART SYSTEM control. Connect the sensor leads to the Tank Sensor terminals on the Low Voltage Connection Board (FIG. 5-3).

High gas pressure switch

If a switch is provided to detect excessive gas pressure, remove the jumper wire from the terminals on the connection board, and then connect them to its normally closed contacts (FIG. 5-3).

Low gas pressure switch

1. If a switch is provided to detect low gas pressure, remove the jumper wire from the terminals on the connection board and connect them to its normally open contacts (FIG. 5-3).
2. If both a high and low gas pressure switch are used, connect their respective contacts in series, and connect them to the terminals on the connection board (FIG. 5-3).

NOTICE

See *Section 4 - Gas Connections* for a detailed explanation regarding high and low gas pressure switch operation.

Flow switch

1. A flow switch is used to guarantee flow through the water heater before allowing it to fire. The flow switch must be installed at the water heater outlet.
2. Connect these terminals to the normally open contacts on the flow switch (FIG. 5-3).

Rate output

This output provides a 0 - 10V signal that is proportional to the firing rate of the water heater. This may be used by a BMS system to monitor the actual rate of the water heater.

ModBus

When the optional ModBus interface module is installed, the RS-485 ModBus cable is connected to these terminals. Use shielded, 2-wire twisted pair cable. If desired, the shield can be connected to ground by installing a jumper wire between terminals 1 and 3 on connector X5 on the optional ModBus interface module.

Water heater Building Management System (BMS)

1. An external control may be connected to control either the firing rate or the set point of the water heater. If the external control uses a set of contacts to enable the water heater, connect the contacts to the Tank Thermostat terminals. Otherwise, the SMART SYSTEM control will be enabled by the 0-10V signal.
2. Make sure the (-) terminal is connected to the (-) or common output terminal of the external control, and the (+) terminal is connected to the (+) or 0 - 10 VDC terminal of the external control. Make sure the (-) voltage is not below ground.

5 Field wiring

Runtime contacts

The SMART SYSTEM control closes a set of dry contacts whenever the burner is running. This is typically used by Building Management Systems to verify that the water heater is responding to a call for heat.

Alarm contacts

The SMART SYSTEM control closes another set of contacts whenever the water heater is locked out or the power is turned off. This can be used to turn on an alarm, or signal a Building Management System that the water heater is down.

Wiring of the cascade

When wiring the water heaters for Cascade operation, select one water heater as the Leader water heater. The remaining water heaters will be designated as Members. See page 36 “Configuration of the Cascade” for a detailed explanation of this procedure.

Connect the tank sensor to the Leader water heater. For the Cascade system to work properly the tank sensor must be installed. The tank sensor should be wired to the low voltage connection board at the terminals marked for the tank sensor (see FIG. 5-3). The Leader control will use the water temperature at the tank sensor to control the operation of the Cascade.

Communication between the Leader water heater and the Member water heaters is accomplished by using shielded, 2-wire twisted pair communication cable. Connect one of the twisted pair wires to Cascade terminal A on each of the Low Voltage Connection boards, and the other wire of the twisted pair to Cascade terminal B on each of the Low Voltage Connection Boards. Connect the shield wires to one of the shield terminals on the Low Voltage Connection Boards (FIG. 5-3). If more than two water heaters are on the Cascade, daisy chain the wiring from the Cascade terminals on the second water heater to the Cascade terminals on the third water heater, then from the third to the fourth, and so on. The connections between heaters can be made in any order, regardless of the addresses of the water heaters. Try to keep each cable as short as possible.

5 Field wiring *(continued)*

Figure 5-3 Low Voltage Field Wiring Connections

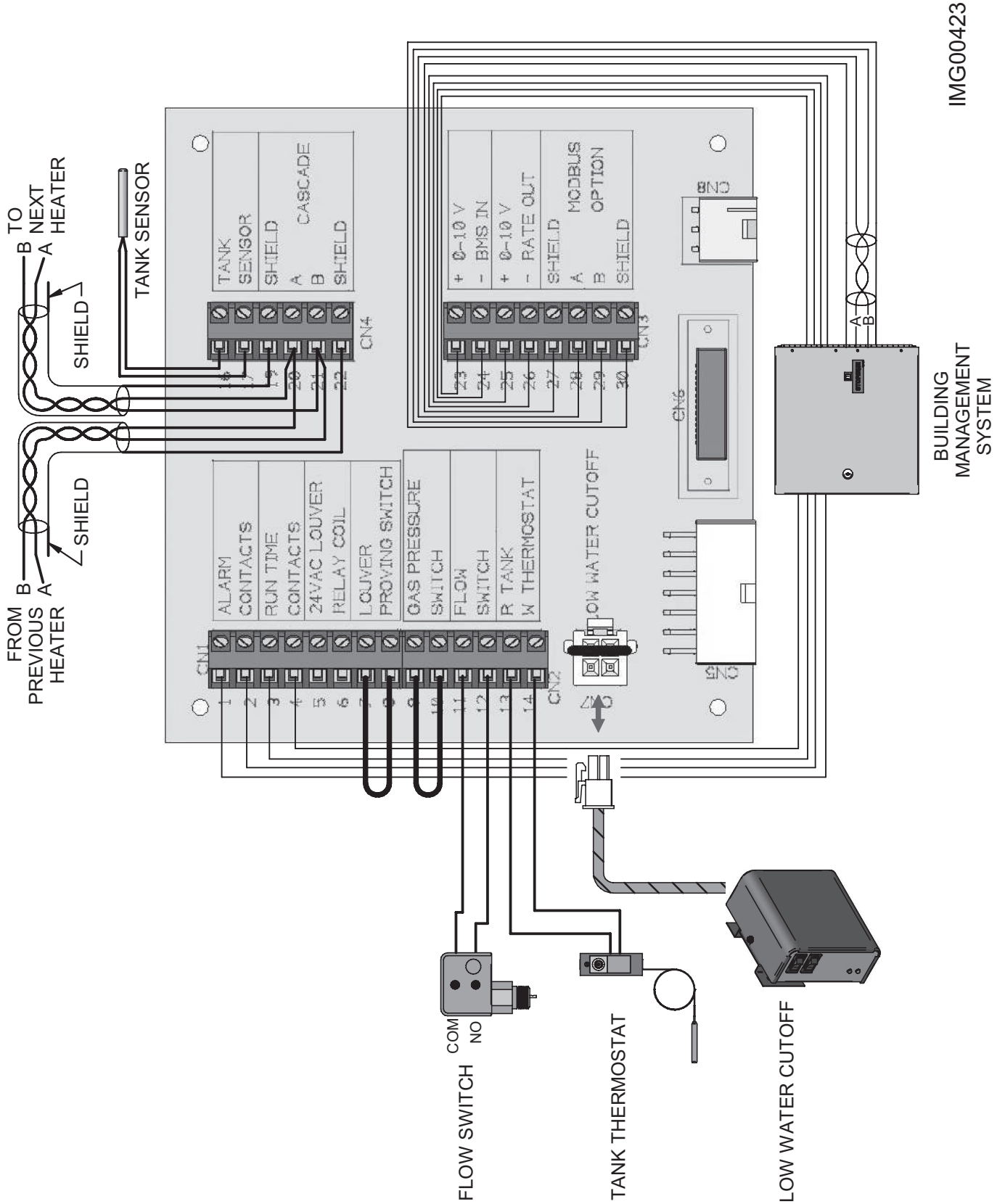

IMG00423

BUILDING MANAGEMENT SYSTEM

6 Condensate disposal

Condensate drain

1. This water heater is a high efficiency appliance that produces condensate.
2. The side of the water heater has a 1/2 inch PVC union for connection of a 1/2 inch PVC pipe (FIG. 6-1).
3. Slope condensate tubing down and away from the water heater into a drain or condensate neutralizing filter. Condensate from the outdoor water heater will be slightly acidic (typically with a pH from 3 to 5). Install a neutralizing filter if required by local codes.

A Neutralizer Kit (FIG. 6-1) is available from the factory.

4. Install the 1/2 inch PVC elbow (field supplied) as shown in FIG. 6-1.
5. Do not expose condensate line to freezing temperatures. Precautions should be taken to protect the condensate management and disposal system during extended periods of outdoor temperatures below 32°F.
6. Use only plastic tubing or piping as a condensate drain line (FIG. 6-1).

NOTICE

Use materials approved by the authority having jurisdiction. In the absence of other authority, PVC and CPVC pipe must comply with ASTM D1785 or D2845. Cement and primer must comply with ASME D2564 or F493.

NOTICE

To allow for proper drainage on large horizontal runs, a second line vent may be required and tubing size may need to increase to 1 inch.

The condensate line must remain unobstructed, allowing free flow of condensate. If condensate is allowed to freeze in the line or if the line is obstructed in any other manner, condensate can exit from the water heater tee, resulting in potential water damage to property.

7. A condensate removal pump is required if the water heater is below the drain. When installing a condensate pump, select one approved for use with condensing water heaters and furnaces. The pump should have an overflow switch to prevent property damage from condensate spillage. The switch should be wired in series with the blocked drain switch inside the water heater (see FIG. 7-1 on page 29).

Figure 6-1 Condensate Disposal

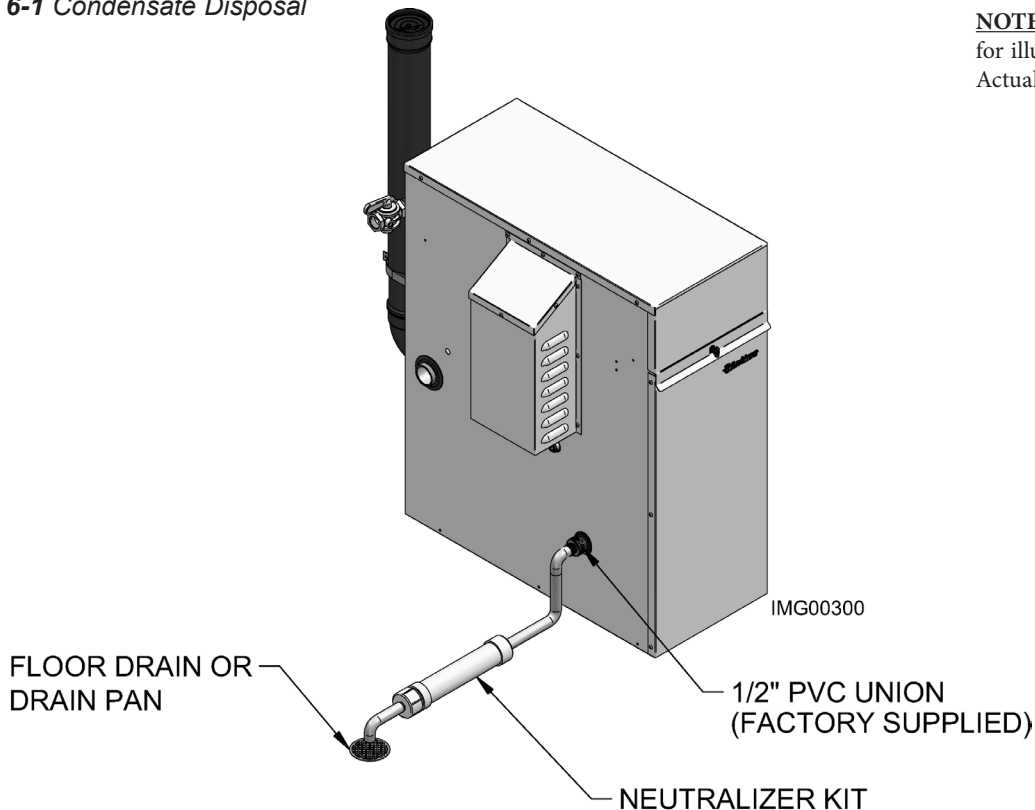

NOTE: Neutralizer shown for illustrative purposes only. Actual neutralizer may vary.

7 Start-up

Check/control water chemistry

NOTICE

Conduct water quality testing prior to installing the appliance. Various solutions are available to adjust water quality.

See the following table for properly operating the water heater with the appropriate water chemistry. Good water quality will help extend the life of the appliance by reducing the effects of scale buildup and corrosion.

Table 7A Water Chemistry

WATER CHEMISTRY		
Specification	Range	Requirement
Hardness	< 5 gpg	Follow recommendations detailed below (See Notice 3)
	5 to 12 gpg	Use Table 3C for pump recommendation
	12 to 15 gpg	Use Table 3C for pump recommendation
	> 15 gpg	Water softening system required (See Notice 4)
Dissolved Solids	< 350 ppm	Hardness level must be met
pH Level	6.5 to 8.5	Acceptable range
Chloride	< 150 ppm	Acceptable range

NOTICE

- Do not use the water heater to directly heat swimming pool or spa water.
- At initial fill and during water heater start-up and testing, check system thoroughly for any leaks. Repair all leaks before proceeding further.
- When water hardness levels are less than 5 gpg or 85.5 mg/l, the following is recommended:
 - Flush and clean existing water heating system prior to installation.
 - Inspect and, if necessary, replace the anodes in any existing tanks.
 - Install a Y-strainer on the inlet of each water heater as detailed in Section 3.
 - Limit the run time of the hot water recirculation loop.
 - Filter the hot water recirculation loop to a level of 10 microns. CAUTION: Check recirculation pump size to verify it is sized for filter addition and upsize if necessary.
- When water softener is required, a Template Assisted Crystallization system is recommended.

Check for gas leaks

WARNING

Before starting the water heater, and during initial operation, smell near the floor and around the water heater for gas odorant or any unusual odor. Remove the top access panel and smell the interior of the water heater enclosure. Do not proceed with startup if there is any indication of a gas leak. Use an approved leak detection solution. Repair any leaks at once.

WARNING

DO NOT adjust gas valve outlet pressure. The gas valve is factory set for the correct outlet pressure. This setting is suitable for natural gas and propane, requiring no field adjustment. Attempting to alter the gas valve outlet pressure could result in damage to the valve, causing potential severe personal injury, death, or substantial property damage.

WARNING

Propane water heaters only – Your propane supplier mixes an odorant with the propane to make its presence detectable. In some instances, the odorant can fade, and the gas may no longer have an odor. Before startup (and periodically thereafter), have the propane supplier verify the correct odorant level in the gas.

Inspect/fill condensate system

Inspect/check condensate lines and fittings

- Inspect the condensate drain line, condensate PVC fittings and condensate trap.

Fill condensate trap with water

- Remove the PVC cap retaining screw from the PVC cap (FIG. 7-1).
- Remove the 2 inch PVC cap with the switch located at the top of the trap (FIG. 7-1).
- Fill with fresh water until the water begins to pour out of the drain.
- Replace the cap. Press the cap onto the trap until the cap makes contact with the drain.
- Replace the retaining screw.

WARNING

The condensate trap (FIG. 7-1) must be filled with water during all times of water heater operation to avoid flue gas emission from the condensate drain line. Failure to fill the trap could result in severe personal injury or death.

Figure 7-1 Condensate Trap

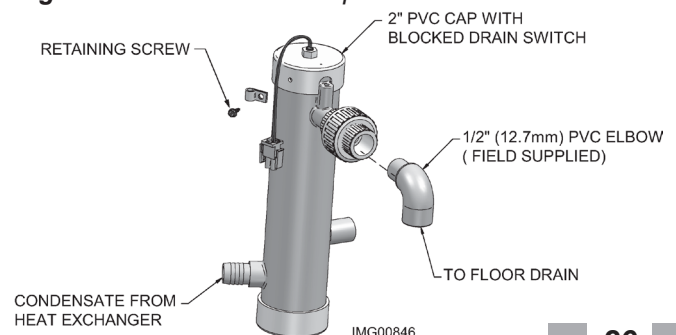

7 Start-up

Final checks before starting the water heater

- ❑ Read the Outdoor Armor Water Heater Service Manual to familiarize yourself with SMART SYSTEM control module operation. Read this manual, pages 33 and 34 for proper steps to start the water heater.
- ❑ Verify the water heater and system are full of water and all system components are correctly set for operation.
- ❑ Verify the preparation procedures of Section 7, page 31 has been completed.
- ❑ Fill the vent condensate trap with water (removing the retaining screw in order to remove the 2 inch PVC cap with the switch located at the top of the trap). Replace the cap. Press the cap onto the trap until the cap makes contact with the drain. Replace the retaining screw.
- ❑ Verify electrical connections are correct and securely attached.

Start the water heater

1. Read and follow the Operating instructions in FIG. 7-2, pages 31.

If water heater does not start correctly

1. Check for loose connections, blown fuse or service switch off?
2. Is water heater water temperature above 200°F?
3. Is tank thermostat or tank set point set below tank temperature?
4. Is gas turned on at meter or water heater?
5. Is incoming gas pressure less than 4 inches w.c.?

If none of the above corrects the problem, refer to the *Troubleshooting Section* of the Outdoor Armor Water Heater Service Manual.

Check system and water heater

❑ Check water piping

1. Check system piping for leaks. If found, shut down the water heater and repair immediately. (See WARNINGS on pages 31 and 32 (startup) regarding failure to repair leaks.)
2. Check Delta T. Reference Section 3 - *System Piping* on page 16 for more information regarding Delta T.
3. Vent any remaining air from the system using manual vents. Air in the system will interfere with circulation and cause heat distribution problems and noise.

❑ Check vent piping and air piping

1. Check for gastight seal at every connection, seam of air piping, and vent piping.

⚠ WARNING Venting system must be sealed gastight to prevent flue gas spillage and carbon monoxide emissions, which will result in severe personal injury or death.

❑ Check gas piping

1. Check around the water heater for gas odor following the procedure on page 22 of this manual (*Connecting Gas Supply Piping*).

⚠ WARNING If you discover evidence of any gas leak, shut down the water heater at once. Find the leak source with a bubble test and repair immediately. Do not start the water heater again until corrected. Failure to comply could result in severe personal injury, death, or substantial property damage.

❑ Propane water heaters – verify conversion

1. Verify propane conversion has been completed per the Propane Conversion instructions.

⚠ WARNING DO NOT adjust gas valve outlet pressure. The gas valve is factory-set for the correct outlet pressure. This setting is suitable for natural gas and propane, requiring no field adjustment. Attempting to alter the gas valve outlet pressure could result in damage to the valve, causing potential severe personal injury, death, or substantial property damage.

⚠ WARNING Outdoor Armor water heaters are typically shipped ready to fire on natural gas. Check water heater rating plate to determine which fuel the water heater is set for. If set to natural gas, it may be converted to LP by installing an orifice or by making a gas valve adjustment (see pages 11 and 12). In order to operate on LP gas, an orifice **MUST BE** installed or a gas valve adjustment **MUST BE** made. Failure to comply could result in severe personal injury, death, or substantial property damage.

Check flame and combustion

1. Turn the main power off to the water heater by placing the “On/Off” switch in the OFF position.
2. Remove the flue temperature sensor from the flue pipe connection. **Note:** Combustion measurements will be made at this point.
3. Turn the main power on to the water heater by placing the “On/Off” switch in the ON position.

7 Start-up *(continued)*

Figure 7-2 Operating Instructions

FOR YOUR SAFETY READ BEFORE OPERATING

WARNING: If you do not follow these instructions exactly, a fire or explosion may result causing property damage, personal injury, or loss of life.

- | | |
|---|---|
| <p>A. This appliance does not have a pilot. It is equipped with an ignition device which automatically lights the burner. Do not try to light the burner by hand.</p> <p>B. BEFORE OPERATING smell all around the appliance area for gas. Be sure to smell next to the floor because some gas is heavier than air and will settle on the floor.</p> <p>WHAT TO DO IF YOU SMELL GAS</p> <ul style="list-style-type: none"> • Do not try to light any appliance. • Do not touch any electric switch; do not use any phone in your building. | <ul style="list-style-type: none"> • Immediately call your gas supplier from a neighbor's phone. Follow the gas supplier's instructions. • If you cannot reach your gas supplier, call the fire department. <p>C. Use only your hand to move the gas control switch. Never use tools. If the switch will not move by hand, don't try to repair it, call a qualified service technician. Force or attempted repair may result in a fire or explosion.</p> <p>D. Do not use this appliance if any part has been under water. Immediately call a qualified service technician to inspect the appliance and to replace any part of the control system and any gas control which has been under water.</p> |
|---|---|

OPERATING INSTRUCTIONS

- | | |
|--|---|
| <ol style="list-style-type: none"> 1. STOP! Read the safety information above on this label. 2. Set the thermostat to lowest setting. 3. Turn off all electric power to the appliance. 4. This appliance is equipped with an ignition device which automatically lights the burner. Do not try to light the burner by hand. 5. Remove front door. 6. Move switch to the "OFF" position. 7. Wait five (5) minutes to clear out any gas. If you then smell gas, STOP! Follow "B" in the safety information above this label. If you don't smell gas, go to next step. | <ol style="list-style-type: none"> 8. Move the switch to the "ON" position. 9. Install front door. 10. Turn on all electric power to appliance. 11. Set thermostat to desired setting. 12. If the appliance will not operate, follow the instructions "To Turn Off Gas To Appliance" and call your service technician or gas supplier. |
|--|---|

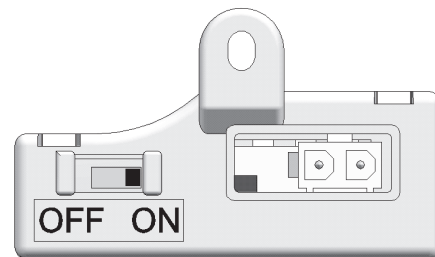

TO TURN OFF GAS TO APPLIANCE

- | | |
|---|---|
| <ol style="list-style-type: none"> 1. Set the thermostat to lowest setting. 2. Turn off all electric power to the appliance if service is to be performed. 3. Remove front door. | <ol style="list-style-type: none"> 4. Move the switch to the "OFF" position. 5. Install front door. |
|---|---|

7 Start-up *(continued)*

Check flame and combustion *(continued)*

4. Place the water heater into the active position by pressing the RIGHT SELECT [ON] key (FIG. 8-1, page 38).
5. Locate the pinhole button below the RESET button on the display board (FIG. 8-1). Insert a thin wire (such as a paper clip) into the hole and press the button once and hold for 5 seconds to place the water heater into Service Mode. In Service Mode the water heater will fire at ignition speed and will then modulate up to full fire.
6. Insert the probe from a combustion analyzer into the flue outlet.
7. Once the water heater has modulated up to full fire, measure the combustion. The values should be in the range listed in Table 7A below. The CO levels should be less than 150 ppm for a properly installed unit.

If the combustion is not within the specified range, reference the *Troubleshooting Section* of the Outdoor Armor Water Heater Service Manual for possible causes and corrective actions.

Table 7A Flue Products Chart

Natural Gas		Propane	
CO ₂	O ₂	CO ₂	O ₂
8.0% - 10%	3.0% - 6.5%	9.0% - 11%	4.1% - 6.9%

8. Once the combustion analysis is complete, test the safety shutoff device by turning the manual shutoff valve to the OFF position and ensuring that the water heater shuts down and registers an alarm. Open the manual shutoff valve and reset the control.
9. Turn the main power off to the water heater.
10. Place the water heater back into normal operation.

Set water heater operation

Set tank set point temperature

NOTICE

Please note that the brackets ([]) denote screen status.

The NAVIGATION dial may be used during normal operation to adjust the tank set point temperature.

1. From the Status Screen press the NAVIGATION dial.
2. Press the NAVIGATION dial then rotate the NAVIGATION dial to adjust the temperature.
3. Once the desired temperature is displayed, press the RIGHT SELECT [SAVE] key.
4. Press the RIGHT SELECT [HOME] key to upload the changes.
5. If the RIGHT SELECT [SAVE] key is not pressed, the new settings will be discarded.

Verify WHR circulator mode

When the tank thermostat or tank sensor calls for heat, the SMART SYSTEM control will turn on the water heater pump. When the DHW call for heat ends, the water heater pump will continue to run for a period of time. This pump delay is set at the factory to 60 seconds. If a shorter or longer delay is desired, the appropriate parameter in the control must be changed. See the Outdoor Armor Water Heater Service Manual for a detailed explanation of this procedure.

7 Start-up

Set clock

NOTICE

Please note that the brackets ([]) denote screen status.

The SMART SYSTEM control has a built-in clock that it uses for its night setback feature and for logging events. This clock must be set when the water heater is installed, and anytime the water heater has been powered off for more than 4 hours. Use the following procedure to set the clock:

1. Press and hold the LEFT SELECT [MENU] key for at least 5 seconds.
2. The display changes to read [PASSWORD], with four (4) zeros below it.
3. Press the RIGHT SELECT [SAVE] key.
4. The display will then show a menu with the time and date and temperature unit.
5. Press the NAVIGATION dial twice.
6. Turn the NAVIGATION dial to adjust the hours. Press the NAVIGATION dial.
7. Turn the NAVIGATION dial to adjust the minutes. Press the NAVIGATION dial.
8. Turn the NAVIGATION dial to adjust the month. Press the NAVIGATION dial.
9. Turn the NAVIGATION dial to adjust the date. Press the NAVIGATION dial.
10. Turn the NAVIGATION dial to adjust the year. Press the RIGHT SELECT [SAVE] key.
11. Press the RIGHT SELECT [HOME] key.

NOTICE

The internal clock does not adjust for Daylight Savings Time and therefore, will require a manual adjustment.

The clock is automatically updated whenever a PC is connected and the Win Pro-Installer program is started.

Configuration of the cascade

NOTICE

Please note that the brackets ([]) denote screen status.

When installed in a Cascade system, the individual controls must be programmed for cascade operation. This is accomplished by accessing the control parameters.

Press the [MENU] key for at least five (5) seconds. Input the Installer code as described in the Outdoor Armor Service Manual. Once the control parameters have been accessed, use the NAVIGATION dial to select the Control Mode parameters. Press the NAVIGATION dial to access these parameters.

Rotate the NAVIGATION dial to select the parameter "Cascade Address". Press the NAVIGATION dial to access this parameter. Each appliance in the Cascade system must be programmed with its own address. The water heater designated as the Leader will have an address of 0. The remaining water heaters in the Cascade will be Members and have addresses from 1 - 7. Rotate the NAVIGATION dial to select the appropriate address. Press the RIGHT SELECT [SAVE] key.

Press the RIGHT SELECT [HOME] key to upload the address into the control. Repeat this procedure for all water heaters in the Cascade, designating the Leader control and the Member controls.

Note: A tank sensor must be installed when operating outdoor water heaters in Cascade.

8 Operating information

General

How the water heater operates

The outdoor water heater uses an advanced stainless steel heat exchanger and electronic control module that allows fully condensing operation. The blower pulls in air and pushes flue products out of the water heater through the heat exchanger and flue piping. The control module regulates blower speed to control the water heater firing rate. The gas valve senses the amount of air flowing into the water heater and allows only the right amount of gas to flow.

Control inputs and outputs

Tank thermostat / tank sensor

Either of these inputs will tell the water heater to provide heat to the water tank. If a tank sensor is connected, the SMART SYSTEM control will ignore the tank thermostat.

0 - 10VDC input (set point or power)

The outdoor water heater can be controlled by a Building Management System (BMS) using a 0 - 10 VDC signal. The control can be configured by the installer to use this signal to either control set point or firing rate. This signal can be sent to the heater through ModBus as well.

Temperature control

Modulation

The outdoor water heater is capable of modulating its firing rate from a minimum of 20% to a maximum of 100%. The firing rate is dictated by the hot water draw and various other temperature limitations.

Night setback

The controller may be programmed to reduce the DHW set point during certain times each week. Seven different start and stop times may be programmed for the DHW setback.

Flame current support

To prevent nuisance shutdowns when the water heater is firing at minimum rates, the control will increase fan speed when the flame signal drops too low.

Protection features

Outlet temperature, flue temperature, and temperature rise limiting

The outlet temperature is monitored by the water heater outlet temperature sensor. When the outlet temperature exceeds 185°F, the unit will reduce the fan speed. If the outlet water temperature exceeds 195°F the control will shut the unit down until it cools off.

The control module monitors the flue temperature by a sensor located in the flue exhaust. If the flue temperature exceeds 215°F the control will reduce the maximum fan speed. If the flue temperature exceeds 240°F the control will shut the unit down. The unit will restart automatically once the flue temperature drops 25°F and the minimum off time has expired.

The control monitors the temperature difference between the inlet and the outlet sensor. If the control determines the temperature rise is too high, it will either reduce the firing rate or shut down the unit as appropriate.

The unit will restart automatically once the temperature difference has dropped below the allowable rise and the minimum off time has expired.

Freeze protection

DO NOT install the water heater in a location likely to freeze.

The following integral feature of the SMART SYSTEM control module provides some protection for the water heater.

- The SMART SYSTEM control module provides freeze-up protection as follows when the water heater water temperature drops below 45°F:
- Below 45°F, the water heater pump operates constantly.
- Below 37°F, the water heater turns on.
- The water heater and pump will turn off if water heater water temperature rises above 45°F.



CAUTION

This feature of the SMART SYSTEM control module does not eliminate the possibility of freezing. The installation must still use recognized design, installation and maintenance practice to prevent freeze potential for the water heater.

8 Operating information

Monitor external limits

Connections are provided on the connection board for external limits such as a flow switch and gas pressure switches. The SMART SYSTEM will shut off the burner and inhibit relighting whenever any of these external limits open.

Runtime and alarm outputs

The water heater provides dry contacts for indicating when the water heater is running, and when it is unable to operate.

Runtime and cycle counting

The control uses a timer to monitor the total hours of burner operation. The timer monitors the time the water heater is firing.

The control uses two (2) ignition counters to monitor the amount of water heater cycles. The first counter counts all ignitions of the control. The second counter counts only ignition attempts that have failed.

Service reminder

The control can be programmed for service reminder notification. This notification will become active when either a set amount of time has expired, or a set amount of running hours or cycles has expired (all adjustable by the installer). The display will show a Maintenance Required screen. The installer's name and phone number can be programmed into the control. This information will appear on the Maintenance Required screen. The service reminder notification can be reset or disabled by the installer.

The time dependent feature has been disabled by the manufacturer. To enable this feature change the parameter to the desired time interval, reference the Outdoor Armor Service Manual for details regarding parameters.

Error logging

The control will hold in memory the last 10 lockouts as well as the last 10 blockings. The date and time of the occurrence will be recorded as well. Only the 10 most current occurrences of each will be held in memory.

Water heater temperature regulation

Operating temperature (target)

The SMART SYSTEM control module senses water temperature and regulates water heater firing and firing rate to achieve a target temperature. The target temperature can be set between 60°F and 190°F.

High limit operations

The outdoor water heater is equipped with a fixed automatic reset high limit and an adjustable manual reset high limit. The automatic reset high limit has a set point of 200°F and the manual reset high limit has a maximum set point of 210°F.

When the outlet temperature exceeds 200°F, the automatic high limit action occurs. The water heater shuts down until the outlet water temperature cools below 190°F, and a 60 second timer has expired. If the outlet temperature continues to increase, the manual reset high limit action will occur at 210°F.

High limit test procedure

NOTICE

Please note that the brackets ([]) denote screen status.

1. Turn ON the main power to the water heater by placing the ON/OFF switch in the ON position.
2. From the Status Screen, press the NAVIGATION dial to access the Set Points Screen.
3. Press the LEFT SELECT (LIMITS) key.
4. Select the manual reset high limit (MRHL) by rotating the NAVIGATION dial counterclockwise, then press the NAVIGATION dial.
5. Decrease the set point of the MRHL to below the current outlet temperature (or to its minimum setting, whichever is higher) by turning the NAVIGATION dial counterclockwise.
6. Press the RIGHT SELECT [SAVE] key.
7. Press the RIGHT SELECT [HOME] key. The new parameter will upload to the control.
8. If the current outlet temperature is above the new MRHL set point, the MRHL will function causing water heater lockout. If this occurs, skip to Step 11.
9. If the current outlet temperature is below the new MRHL set point, locate the pinhole (SERVICE button) below the RESET button on the display board. Insert a thin probe (such as a paper clip) into the hole and press the button continuously for five (5) seconds to place the water heater into Service Mode. In Service Mode, the water heater will fire at ignition speed and will then modulate up to full fire.
10. Once the outlet temperature rises up to the MRHL set point, the MRHL will function, causing the water heater to shut down and lock out.
11. Repeat Steps 2, 3 and 4.
12. Set the MRHL to the appropriate set point by turning the NAVIGATION dial clockwise.
13. Repeat Steps 6 and 7.
14. Press the RESET button to clear the lockout.
15. If needed, press the RIGHT SELECT [STOP] key to exit Service Mode.

Low water cutoff protection

1. The SMART SYSTEM control module uses temperature sensing of both supply and return areas of the heat exchanger. If the flow rate is too low or the outlet temperature too high, the control module modulates and shuts the water heater down. This ensures water heater shutdown in the event of low water or low flow conditions.
2. Some codes and jurisdiction may accept these integral features of the control in lieu of requiring an additional limit control or low water cutoff. Consult local jurisdiction to determine. A low water cutoff is available from the factory (100173773).

8 Operating information *(continued)*

Cascade

When multiple water heaters are installed, they can be wired together in a cascade sequence. A maximum of eight water heaters can be controlled from a single control. In this application one water heater would be designated as the Leader control and all others would be designated as Member controls. The Leader control can be programmed to use Lead/Lag or Efficiency Optimization control methods.

Once the Leader water heater receives a call for heat from a tank sensor, BMS or ModBus, the control will determine what the set point will be. A fixed temperature set point can be programmed into the control. See page 35 of this manual to program the set point.

If the water temperature at the tank is less than the set point - differential, then the control will initiate a call for heat on the Cascade (see the Outdoor Armor Water Heater Service Manual for an explanation of the differential). The Leader will energize the lead water heater on the Cascade. For a new startup this will be the Leader water heater.

Sequence of the cascade

To equalize the runtime of all water heaters on the Cascade, the firing sequence will automatically be changed at set intervals.

For the first 24 hours after initializing the Cascade, the sequence will be changed every hour. After that the sequence will be changed once every 24 hours. The switching on/off sequence will be as follows:

TIME	SWITCHING ON SEQUENCE
Start	L-M1-M2-M3-M4-M5-M6-M7
+ 1 hour	M1-M2-M3-M4-M5-M6-M7-L
+ 2 hours	M2-M3-M4-M5-M6-M7-L-M1

If a water heater locks out, it will automatically be given the lowest priority for the rest of that 24 hour period.

Night Setback operation with cascade

Night Setback operation of the water heaters within the Cascade is available. Programming of the Night Setback will be done through the Leader water heater. Refer to the Outdoor Armor Water Heater Service manual for information regarding Night Setback.

Access modes

User

The user can adjust tank target temperatures by pressing the NAVIGATION dial when “↓SETPOINTS” is flashing at the bottom of the display. The date, time, and the temperature units can also be changed (see page 36).

Installer

Most parameters are available only to the installer, accessible by entering the installer password, see the Outdoor Armor Water Heater Service Manual.

Saving parameters *(reference the Parameter Table in the Outdoor Armor Water Heater Service Manual)*

NOTICE

Please note that the brackets ([]) denote screen status.

To save parameters and exit programming:

Press the RIGHT SELECT [SAVE] key and then press the RIGHT SELECT [HOME] key.

















To enter a parameter and continue programming:

Press the RIGHT SELECT [SAVE] key 1 time to return to the parameter listings; press again to return to the menu listings. Remember to press the RIGHT SELECT [HOME] key when finished programming in order to save the changes made.

See the Outdoor Armor Water Heater Service Manual for a detailed description of parameters and access modes.

8 Operating information

Sequence of operation

OPERATION	DISPLAY
1. The control will turn on the water heater pump (always ON except in Night Setback). The flow switch and/or LWCO must close.	START  TANK: 119°F(125) MENU  SCREEN SHDN
2. Air pressure switch and blocked drain switch must close.	START  TANK: 119°F(125) MENU  SCREEN SHDN
3. The control starts a 15 second prepurge cycle.	PRE-PURGE  TANK: 119°F(125) MENU  SCREEN SHDN
4. The control starts a 4 second trial for ignition by firing the spark electrode and opening the gas valve.	IGNITION  TANK: 119°F(125) MENU  SCREEN SHDN
5. If flame is not detected within 1 second after the sparking ends, the control will perform a 10 second post-purge, then start another prepurge cycle and try to light the burner again. The control will perform a total of 4 attempts before locking out.	POST-PURGE  TANK: 119°F(125) MENU  SCREEN SHDN
6. If flame is detected, it holds the firing rate steady for 5 seconds to let the flame stabilize, then it begins to modulate the firing rate based on a set point or some other command (such as a 0-10V BMS signal).	42%   TANK: 119°F(125) MENU  SCREEN SHDN
7. Once the call for heat is satisfied, the control will turn off the burner. The blower will continue to run during a 10 second postpurge.	POST-PURGE TANK: 128°F(125) MENU  SCREEN SHDN
8. The water heater pump will continue to run for its respective pump delay time before turning off. A 60 second anti-cycle period will start, which will delay any new call for heat until it times out.	BLOCKED ANTI-CYCLING TANK: 128°F(125) MENU  SCREEN SHDN
9. In Standby, ready to start a new cycle.	STANDBY TANK: 128°F(125) MENU  SETPOINT SHDN

8 Operating information *(continued)*



Outdoor Armor water heater control module

Use the control panel (FIG. 8-1) to set temperatures, operating conditions, and monitor water heater operation.

Figure 8-1 Control Panel

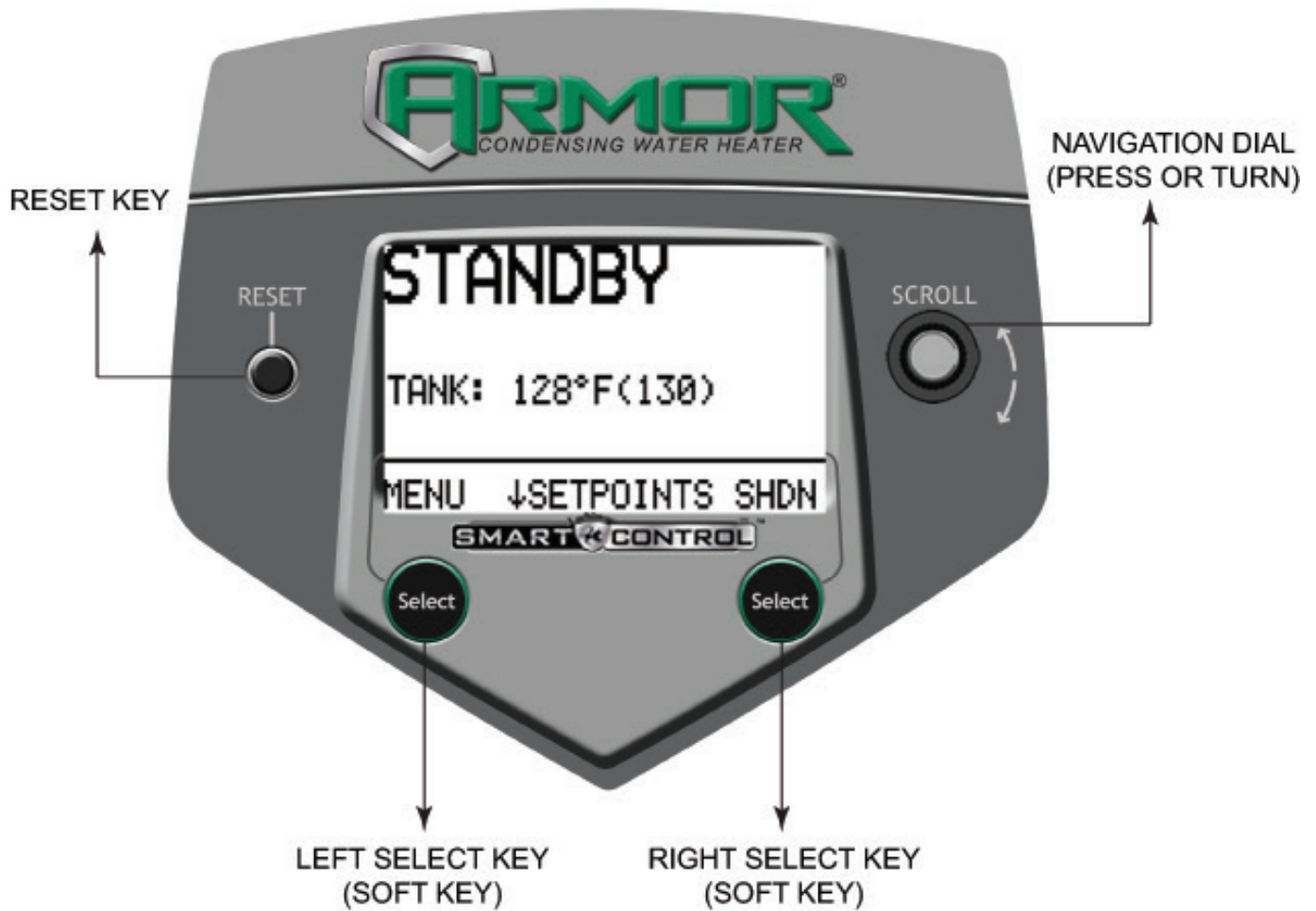

The information on the bottom of the display shows the functions of the two SELECT keys (on either corner), and the NAVIGATION dial (in the center):

- MENU = Left SELECT Key
- SETPOINTS = NAVIGATION Dial - Pressing Down
- SHDN = Right SELECT Key

8 Operating information

Figure 8-2 Status Display Screen

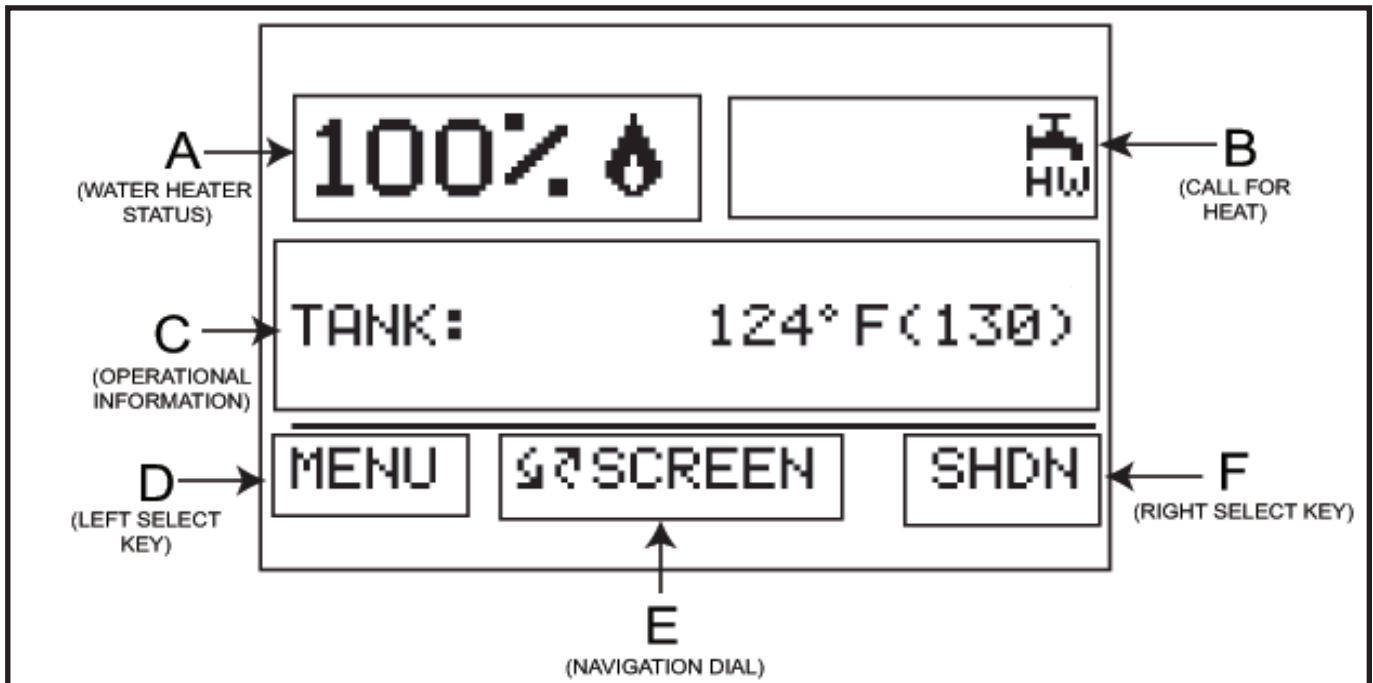

Status Display Screens

Section	Display	Description
A (Water heater Status Bar)	STANDBY	The unit has not received a call for heat from a remote thermostat nor has it received a call for heat from a DHW thermostat.
	START	The unit has begun a burn cycle and is checking all safety circuits.
	PREPURGE	The unit has initiated a 10 second purge period on a call for heat.
	IGNITION	The unit has begun a 4 second spark period to ignite the main burner.
	%	The unit has fired and is running at the displayed percentage.
	POSTPURGE	The call for heat has been satisfied and the unit runs the fan for an additional 10 seconds to clear the combustion chamber and vent system of residual flue products.
	SHUTDOWN	The unit has been placed in the OFF position.
	SETPOINT MET	The controlled temperature has exceeded its set point and its offset.
	BLOCKED	The unit has detected a condition that has temporarily interrupted the current call for heat.
B (Call for Heat Indicators)		The tank thermostat or sensor has a call for heat.
		The unit is being controlled by a 0 - 10V BMS signal.
		The member unit is supplying heat while in Cascade Mode.

8 Operating information *(continued)*

Status Display Screens <i>(cont'd)</i>		
Section	Display	Description
C (Operational Information)	TANK:	The temperature read by the tank sensor (if connected).
	INLET TEMP:	The temperature read at the inlet to the heat exchanger.
	OUTLET TEMP:	The temperature read at the outlet of the heat exchanger.
	DELTA T:	The temperature difference between the inlet and the outlet of the heat exchanger.
	FLUE TEMP:	The temperature read by the flue sensor.
	FLAME CURRENT:	The current measured by the flame sense circuit.
	FAN SPEED:	The speed of the combustion blower.
	SYSTEM PUMP:	The status of the recirculation pump output.
	DHW PUMP:	The status of the DHW pump output.
	BMS VOLTAGE:	The voltage received from a BMS system.
	RATE OUTPUT:	A 0 - 10V signal indicating the firing rate of the water heater.
	DHW RUN HOURS:	The total hours of operation in the DHW Mode.
	DHW CYCLES:	The total burner cycles in the DHW Mode.
	LAST 10 FAULTS NO:	The last 10 lockouts.
D (LEFT SELECT key function)	MENU	Press and hold the LEFT SELECT key for 5 seconds to enter the Menu Screen.
	EXIT	Press the LEFT SELECT key to exit the current screen or setting.
	YES	Press the LEFT SELECT key to confirm that the water heater needs to shutdown.
	LIMITS	Press the LEFT SELECT key to enter the screen that allows you to adjust the limit settings.
	HOME	Press the LEFT SELECT key to return to the Status Screen and upload parameter changes.

8 Operating information

Status Display Screens <i>(cont'd)</i>		
Section	Display	Description
E (NAVIGATION Dial Function)	↻ SCREEN	Turning the NAVIGATION dial will select the next or previous Status Screen.
	↓ NEXT	Pressing the NAVIGATION dial will show the next fault, NSB (Night Setback) trigger, or ramp delay setting.
	↓ SELECT	Pressing the NAVIGATION dial will select the setting indicated by the cursor.
	↓ SETPOINTS	Pressing the NAVIGATION dial will display the Set Points Screen.
	↻ SCROLL	Turning the NAVIGATION dial will move the cursor up or down.
	↻ ADJUST	Turning the NAVIGATION dial will increase or decrease the current setting.
F (RIGHT SELECT key function)	SHDN	Press the RIGHT SELECT key to turn the water heater OFF.
	ON	Press the RIGHT SELECT key to turn the water heater ON.
	NO	Press the RIGHT SELECT key to cancel the shutdown operation.
	SAVE	Press the RIGHT SELECT key to save the current change.
	HOME	Press the RIGHT SELECT key to return to the Status Screen and upload parameter changes.

9 Maintenance

Maintenance and annual startup

Table 9A Service and Maintenance Schedules

Service technician (see the following pages for instructions)		Owner maintenance	
ANNUAL START-UP	<p>General:</p> <ul style="list-style-type: none"> • Address reported problems • Inspect interior; clean and vacuum if necessary; • Clean condensate trap and fill with fresh water • Check for leaks (water, gas, flue, condensate) • Verify • Flue and air lines in good condition and sealed tight • Check system water pressure/system piping/expansion tank • Check control settings • Check ignition and flame sense electrodes (sand off any deposits; clean and reposition) • Check wiring and connections • Perform start-up checkout and performance verification per Section 7 of this manual. • Flame inspection (stable, uniform) • Flame signal (at least 10 microamps at high fire) • Clean the heat exchanger if flue temperature is more than 54°F above return water temperature. • Check Delta T (Temperature Rise) <p>If combustion or performance indicate need:</p> <ul style="list-style-type: none"> • Clean heat exchanger • Remove and clean burner using compressed air only • Clean the blower wheel 	Daily	<ul style="list-style-type: none"> • Check water heater area
		Monthly	<ul style="list-style-type: none"> • Check air and vent termination screens • Check relief valve • Check condensate drain system • Check automatic air vents • Check Delta T (Temperature Rise) • Remove debris from Y-strainer per manufacturer's instructions • Check building recirculation filter (if filter required) • Check and clean any debris or obstruction from bird screens (if equipped)
		Every 6 months	<ul style="list-style-type: none"> • Check water heater piping (gas and water) for leaks • Operate relief valve • Check water chemistry

9 Maintenance

⚠ WARNING

Follow the service and maintenance procedures given throughout this manual and in component literature shipped with the water heater. Failure to perform the service and maintenance could result in damage to the water heater or system. Failure to follow the directions in this manual and component literature could result in severe personal injury, death, or substantial property damage.

⚠ WARNING

The water heater should be inspected annually only by a qualified service technician. In addition, the maintenance and care of the water heater designated in Table 9A and explained on the following pages must be performed to assure maximum water heater efficiency and reliability. Failure to service and maintain the water heater and system could result in equipment failure.

⚠ WARNING

Electrical shock hazard – Turn off power to the water heater before any service operation on the water heater except as noted otherwise in this instruction manual. Failure to turn off electrical power could result in electrical shock, causing severe personal injury or death.

Address reported problems

1. Inspect any problems reported by the owner and correct before proceeding.

Inspect water heater area

1. Verify that water heater area is free of any combustible materials, gasoline and other flammable vapors and liquids.
2. Verify that air opening area is free of any of the contaminants listed in *Section 1 - Determine Water Heater Location*. If any of these are present in the water heater intake air vicinity, they must be removed.

Inspect water heater interior

1. Remove the front access cover and inspect the interior of the water heater.
2. Vacuum any sediment from inside the water heater and components. Remove any obstructions.

Clean condensate trap

1. Inspect the condensate drain line, condensate PVC fittings, and condensate trap.
2. Remove the PVC cap retaining screw from the PVC cap (FIG. 9-1).
3. Remove the 2 inch PVC cap with the switch located at the top of the trap (FIG. 9-1).
4. Remove any sediment in the trap.
5. Fill with fresh water until the water begins to pour out of the drain.
6. Replace the cap. Press the cap onto the trap until the cap makes contact with the drain.
7. Replace the retaining screw.

Figure 9-1 Condensate Trap

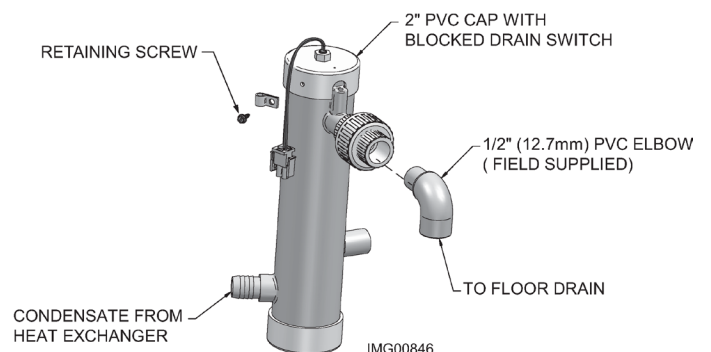

⚠ WARNING

The condensate trap must be filled with water during all times of water heater operation to avoid flue gas emission from the condensate drain line. Failure to fill the trap could result in severe personal injury or death.

Check all piping for leaks

⚠ WARNING

Eliminate all system or water heater leaks. Leaking water may cause severe property damage.

1. Inspect all water and gas piping and verify to be leak free.
2. Look for signs of leaking lines and correct any problems found.
3. Check gas line using the procedure found in *Section 4 - Gas Connections*.

Flue vent system and air piping

1. Visually inspect the entire flue gas venting system and air piping for blockage, deterioration or leakage. Repair any joints that show signs of leakage. Verify that the air inlet pipe internal to the appliance is connected and properly sealed.
2. Verify that water heater vent discharge and air intake are clean and free of obstructions.

9 Maintenance *(continued)*

⚠ WARNING Failure to inspect for the above conditions and have them repaired can result in severe personal injury or death.

Check water system

1. Verify all system components are correctly installed and operational.
2. Check the cold fill pressure for the system. Verify it is correct (must be a minimum of 12 PSI).
3. Watch the system pressure as the water heater heats up (during testing) to ensure pressure does not rise too high. Excessive pressure rise indicates expansion tank sizing or performance problem.
4. Inspect automatic air vents and air separators. Remove air vent caps and briefly push valve to flush vent. Replace caps. Make sure vents do not leak. Replace any leaking vents.

Check expansion tank

1. Expansion tanks provide space for water to move in and out as the heating system water expands due to temperature increase or contracts as the water cools. Tanks may be open, closed or diaphragm or bladder type. See *Section 3 - System Piping* for suggested best location of expansion tanks and air eliminators.

Check water heater relief valve

1. Inspect the relief valve and lift the lever to verify flow. Before operating any relief valve, ensure that it is piped with its discharge in a safe area to avoid severe scald potential. Read *Section 3 - System Piping* before proceeding further.

⚠ WARNING Safety relief valves should be re-inspected **AT LEAST ONCE EVERY THREE YEARS**, by a licensed plumbing contractor or authorized inspection agency, to ensure that the product has not been affected by corrosive water conditions and to ensure that the valve and discharge line have not been altered or tampered with illegally. Certain naturally occurring conditions may corrode the valve or its components over time, rendering the valve inoperative. Such conditions are not detectable unless the valve and its components are physically removed and inspected. This inspection must only be conducted by a plumbing contractor or authorized inspection agency – not by the owner. Failure to re-inspect the water heater relief valve as directed could result in unsafe pressure buildup, which can result in severe personal injury, death, or substantial property damage.

⚠ WARNING Following installation, the valve lever must be operated **AT LEAST ONCE A YEAR** to ensure that waterways are clear. Certain naturally occurring mineral deposits may adhere to the valve, rendering it inoperative. When manually operating the lever, water will discharge and precautions must be taken to avoid contact with hot water and to avoid water damage. Before operating lever, check to see that a discharge line is connected to this valve directing the flow of hot water from the valve to a proper place of disposal. Otherwise severe personal injury may result. If no water flows, valve is inoperative. Shut down the water heater until a new relief valve has been installed.

2. After following the above warning directions, if the relief valve weeps or will not seat properly, replace the relief valve. Ensure that the reason for relief valve weeping is the valve and not over-pressurization of the system due to expansion tank waterlogging or undersizing.

Inspect ignition and flame sense electrodes

1. Remove the ignition and flame sense electrodes from the water heater heat exchanger access cover.
2. Remove any deposits accumulated on the ignition/flame sense electrode using sandpaper. If the electrodes cannot be cleaned satisfactorily, replace with new ones.
3. Replace ignition/flame sense electrode, making sure gasket is in good condition and correctly positioned.

Check ignition ground wiring

1. Inspect water heater ground wire from the heat exchanger access cover to ground terminal strip.
2. Verify all wiring is in good condition and securely attached.
3. Check ground continuity of wiring using continuity meter.
4. Replace ground wires if ground continuity is not satisfactory.

Check all water heater wiring

1. Inspect all water heater wiring, making sure wires are in good condition and securely attached.

Check control settings

1. Set the SMART SYSTEM control module display to Parameter Mode and check all settings. See Section 1 of the Outdoor Armor Service Manual. Adjust settings if necessary. See Section 1 of the Outdoor Armor Service Manual for adjustment procedures.
2. Check settings of external limit controls (if any) and adjust if necessary.

9 Maintenance

Perform start-up and checks

1. Start water heater and perform checks and tests specified in *Section 7 - Start-up*.
2. Verify cold fill pressure is correct and that operating pressure does not go too high.

Check burner flame

1. Inspect flame through observation window.
2. If the flame is unsatisfactory at either high fire or low fire, turn off water heater and allow water heater to cool down. Remove the burner and clean it thoroughly using a vacuum cleaner or compressed air. Do not use compressed air to clean burner if performed inside a building.
3. Remove the burner, reference FIG. 9-2 below.
4. When replacing the burner, ensure gasket is in good condition and positioned correctly (FIG. 9-2).

Figure 9-2 Burner Assembly

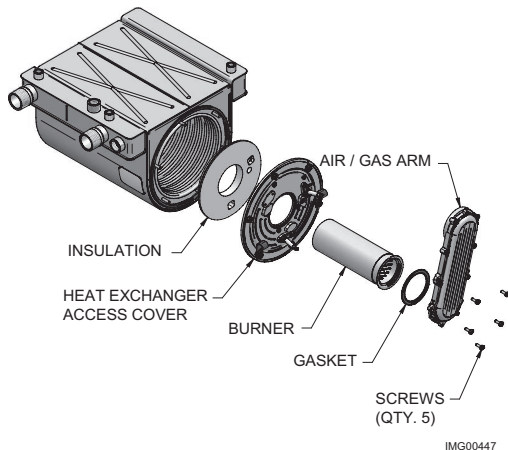

Check flame signal

1. At high fire the flame signal shown on the display should be at least 10 microamps.
2. A lower flame signal may indicate a fouled or damaged flame sense electrode. If cleaning the flame sense electrode does not improve, ground wiring is in good condition, and ground continuity is satisfactory, replace the flame sense electrode.
3. See Section 3 - Troubleshooting in the Outdoor Armor Service Manual for other procedures to deal with low flame signal.

Review with owner

1. Emphasize the need to perform the maintenance schedule specified in this manual.
2. Remind the owner of the need to call a licensed contractor should the water heater or system exhibit any unusual behavior.

3. Remind the owner to follow the proper shutdown procedure and to schedule an annual start-up.

Cleaning heat exchanger

For recommended materials; including brush, appropriate extension(s), refractory cover, and detailed instructions see Table 9B - Heat Exchanger Cleaning Kits.

1. Shut down water heater:
 - Follow the “To Turn Off Gas to Appliance” instructions for the water heater in *Section 7 - Startup*.
2. Allow time for the water heater to cool to ambient temperature if it has been firing.
3. Remove the nuts securing the heat exchanger access cover to the heat exchanger and set aside.
4. Remove the heat exchanger access cover, burner, and gas/air arm assembly.

WARNING The water heater contains ceramic fiber materials. Use care when handling these materials per instructions in the Service Manual. Failure to comply could result in severe personal injury.

5. Remove the condensate hose from the heat exchanger end. Connect a field supplied 3/4" diameter hose to a drain pan. Using field supplied means, cover the refractory in the back of the combustion chamber of the heat exchanger.
6. Use a vacuum cleaner to remove any accumulation on the water heater heating surfaces. Do not use any solvent.
7. Brush the heat exchanger while dry using a nylon bristle brush. **Caution:** DO NOT use a metal brush. Re-vacuum the heat exchanger.
8. Finish cleaning using a clean cloth dampened with warm water. Rinse out debris with a low pressure water supply.
9. Allow the heat exchanger to thoroughly dry.
10. Remove the field supplied rear refractory cover from the back of the combustion chamber of the heat exchanger and reassemble.
11. Close isolation valves on piping to isolate water heater from system. Attach a hose to the water heater drain and flush water heater thoroughly with clean water by using purging valves to allow water to flow through the water make-up line to the water heater.
12. Perform start-up and check-out procedures in the Check Flame and Combustion - *Section 7 - Startup* on pages 32 and 35 of this manual.
13. Replace the access cover and restore water heater to operation.

9 Maintenance *(continued)*

Table 9B Heat Exchanger Cleaning Kits

Model	Kit Number	Part Number	Component Description
201 - 286	100157627	100208804	Rear Refractory Cover
		100208309*	Nylon 4" Wheel Brush*
		100162566	3mm Allen Wrench
		100208311	1/4" x 24" Drill Extension

CAUTION

* Do NOT use a metal brush. Only use the kit provided brush or an equivalent replacement nylon brush.

Figure 9-3 Rope Gasket - Heat Exchanger Door

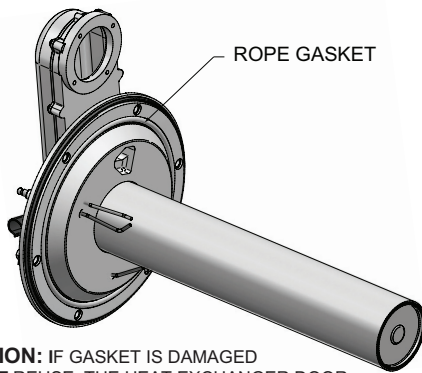

CAUTION: IF GASKET IS DAMAGED DO NOT REUSE, THE HEAT EXCHANGER DOOR MUST BE REPLACED.

NOTICE

Rope gasket is intended for sealing combustion (see FIG. 9-3). If gasket is damaged DO NOT reuse, the heat exchanger door must be replaced. Consult factory for replacement heat exchanger door (kit 100173794 and 100173799).

Check Delta T

1. Check Delta T. Reference *Section 3 - System Piping* on page 16 for more information regarding Delta T.

Oiled bearing circulators

1. The circulator shipped with the outdoor water heater is water-lubricated. No oiling is required.
2. Check other circulators in the system. Oil any circulators requiring oil, following circulator manufacturer's instructions. Over-oiling will damage the circulator.

10 Diagrams

Figure 10-1 Ladder Diagram

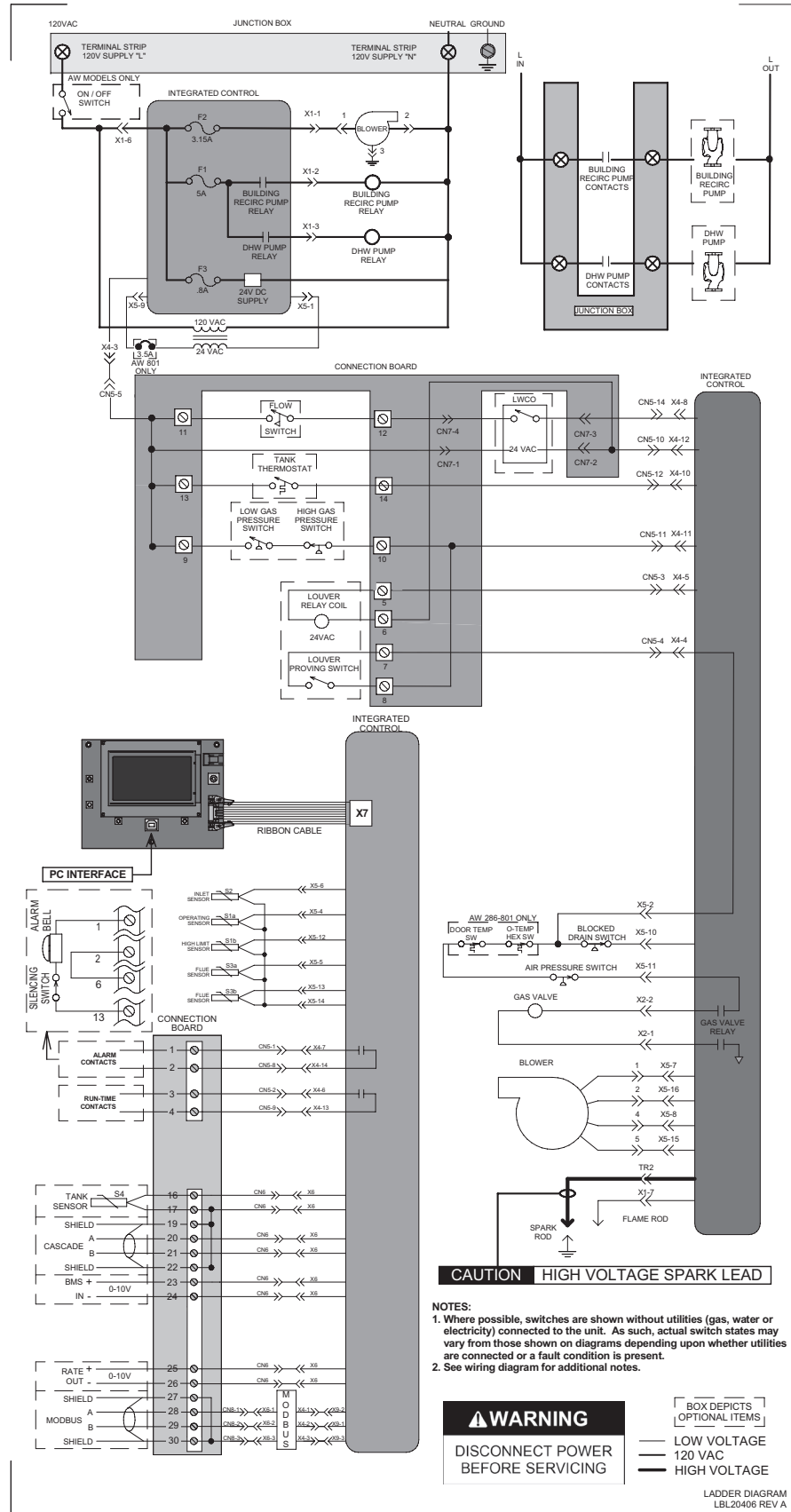

10 Diagrams (continued)

Figure 10-2 Wiring Diagram

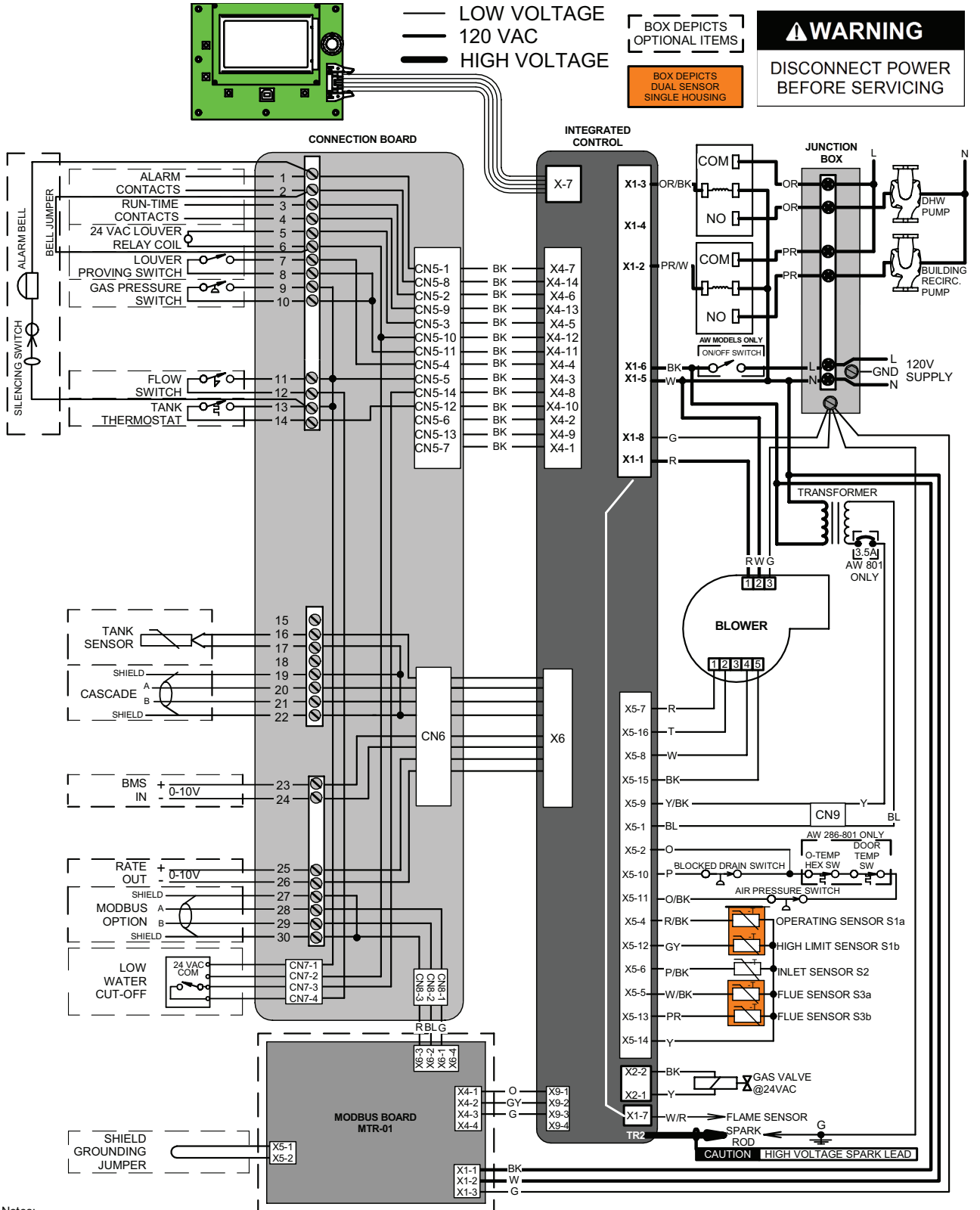

- Notes:
1. All wiring must be installed in accordance with: local, state, provincial and national code requirements per either N.E.C. in USA or C.S.A. in Canada.
 2. If any original equipment wire as supplied with the appliance must be replaced, it must be replaced with wire having same wire gauge (AWG) and rated for a minimum of 105°C. Exceptions: Replacement high voltage spark lead and ribbon cables must be purchased from the factory. Use of a non-approved spark lead or ribbon cables can lead to operational problems which could result in non-repairable damage to the integrated controller or other components.
 3. Actual connector block locations may vary from those shown on diagrams. Refer to actual components for proper connector block locations when using

NOTES

Revision Notes: Revision A (ECO #C10942) initial release.

Revision B (ECO #C11235) reflects updates made to the freezing conditions warnings.

Revision C (ECO C12102) reflects the addition of condensate kit option information for areas that may reach below 32°F as well as a warning not to install OA 400 in these areas and Table 1A on page 8.

Revision D (ECO #C12692) reflects changes made to the wiring and ladder diagrams to match the diagrams used on the Armor Wall Mount (pages 49 and 50).

Revision E (ECO #C12972) reflects the addition of the CSA Low Lead Content logo.

Revision F (ECO #C14411) reflects condensate trap changes (R6594), changes made to Table 4A - Gas Piping Chart on page 23 (R6621), and the addition of the corrosive contaminant warning on pages 3 and 9 (R06313),

Revision G (ECO #C15251) reflects the addition of the burner door temperature switch updates (R6322).

Revision H (ECO C16461) reflects the update of piping diagrams on pages 16 - 20 to illustrate new check valve locations.

Revision I (ECO #C16894) reflects the removal of temperature and pressure gauge information on page 44 (ECR R07715), the update of water content in the Ratings table on page 7 (ECR R07744) and the regulation of pressure drop information on pages 22 and 23.

Revision K (PCP# 3000002702 / CN# 500003259) reflects an update to the wiring diagram on page 50.

Revision L (PCP# 3000005143 / CN# 500006666) reflects the addition of clearance information on page 9.

Revision M (PCP# 3000008814 / CN# 500008824) reflects changes in the water chemistry information on pages 16-21, 31, and 45.

Revision N (PCP #3000010783 / CN #500010520) reflects an update to the low water flow requirement information on pages 16 and 37.

Revision P (PCP #3000010953 / CN #500010523) reflects an update to Table 3C on page 16.

Revision R (PCP #3000027357 / CN #500017568) reflects an update to table 3C on page 16.

Revision T (PCP #3000028700 / CN #500018325) reflects the addition of the optional field supplied contactor on page 26.

Revision U (PCP #3000030779 / CN #500020179) reflects an update to the piping diagrams, Table 7A, Table 9A, and the addition of the building recirculation filter on page 16.

Revision V (PCP #3000031681 / CN #500020790) reflects an update to the ratings table on page 7.

Revision W (PCP #3000038559 / CN #500026649) reflects an update to the water heater sensor material number.

Revision X (PCP #3000043534 / CN #500031265) reflects an update to the monthly maintenance schedule.

Revision Y (PCP #3000049033 / CN #500036140) Adding 201 Model.

Revision AA (PCP #3000056106 / CN #500042631) reflects the removal of discontinued models.

Revision AB (PCP #3000060820 / CN #500046810) reflects the addition of a dielectric notice on page 12.

Revision AC (PCP #3000071552 / CN #500056891) reflects removing obsolete models.