

COMMERCIAL WATER HEATER



OUTDOOR CONDENSING GAS MODELS

2 MODELS FROM 201,000 TO 285,000 BTU/HR

96% THERMAL EFFICIENCY

5:1 TURNDOWN

WEATHER RESISTANT JACKET FOR OUTDOOR
INSTALLATION

OPERATING CONTROL WITH A BUILT-IN
CASCADING SEQUENCER

 **SMART SYSTEM™**



DESIGNED ★ ENGINEERED ★ ASSEMBLED

USA



Lochinvar®
HIGH EFFICIENCY BOILERS & WATER HEATERS

DIMENSIONS AND SPECIFICATIONS

**MODELS:
OAN 201-286**

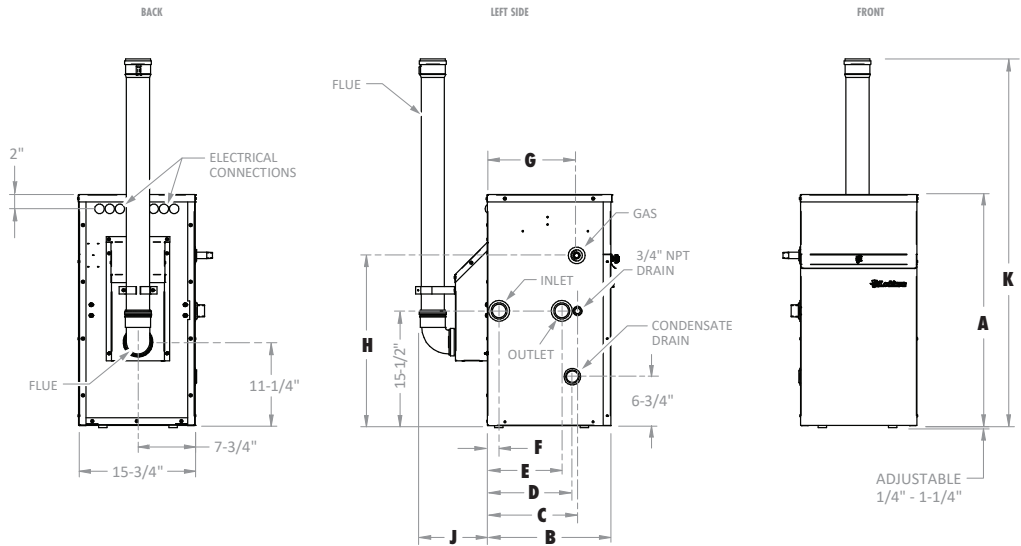

OUTDOOR ARMOR			DIMENSIONS AND SPECIFICATIONS											Gas Conn.	Water Conn.	Vent Size	Ship Wt. (lbs.)
Model Number	Btu/Hr. Input	GPH @ 100° Rise	A	B	C	D	E	F	G	H	J	K					
OAN201PM	201,000	232	31-1/4"	20-1/4"	16-1/2"	15-3/4"	14-1/2"	5-1/4"	16-1/2"	23"	9-1/4"	49-3/4"	1/2"	1-1/4"	3"	181	
OAN286PM	285,000	332	42-1/2"	17-3/4"	13-1/4"	13-1/2"	6-1/4"	2-1/2"	14"	35-3/4"	9-1/4"	52"	3/4"	2"	4"	236	

Notes: Outdoor installation only. All information subject to change. Change "N" to "L" for LP gas models.

AHRI Certified Models

OUTDOOR STANDARD FEATURES

- › AHRI Certified 96% Thermal Efficiency
- › SMART SYSTEM™ Operating Control
- › Modulating Burner with 5:1 Turndown
 - Direct-Spark Ignition
 - Low NOx Operation
 - Sealed Combustion
 - Low Gas Pressure Operation
- › Stainless Steel Heat Exchanger
 - All Welded Construction, Gasketless Design
 - 160 psi Working Pressure
- › Outdoor Rated Vent System
 - UV Resistant Polypropylene
 - Natural to L.P. Conversion Kit
 - Stainless Steel Circulating Pump and Pump Cover
 - On/Off Switch
 - Flow Switch
 - ASME Temperature & Pressure Relief Valve -150 PSI
 - Adjustable Leveling Legs
 - Tank Sensor
 - Adjustable High Limit w/ Manual Reset
 - Automatic Reset High Limit
 - Condensate Trap
 - Zero Clearances to Combustible Material
 - 5 Year Limited Warranty (See Warranty for Details)
 - 1 Year Parts Warranty (See Warranty for Details)

SMART SYSTEM FEATURES

- › SMART SYSTEM Digital Operating Control
 - Multi Color Graphic LCD Display
- › Built-in Cascading Sequencer for up to 8 Water Heaters
 - Lead Lag
 - Efficiency Optimization

- › Building Management System Integration
 - Modbus Communication (Optional)
 - 0-10 VDC Input to Control Modulation or Set point
 - 0-10 VDC Modulation Rate Output
 - 0-10 VDC Input to Enable/Disable call for heat
- Access to BMS Settings Through Graphic LCD Display
- Low Water Flow Safety Control & Indication
- Inlet & Outlet Temperature Sensors & Readout
- Flue Temperature Sensor
- Water Heater Pump Control
- Pump Delay with Freeze Protection
- Pump Exercise
- Night Setback
- Building Recirculation loop Pump Control*
- Night Setback of Building Recirculation Loop*
- Time Clock
- › Maintenance Reminder
 - Ability to program contact name & number into display
- › High Voltage Terminal Strip
 - › 120 VAC / 60 Hertz / 1 Phase Power Supply
 - › Pump Control Contacts
 - › Water Heater Pump Control Contacts
 - › Building Recirculation Pump Control Contacts
- › Low Voltage Terminal Strip
 - 24 VAC Auxiliary Device Relay
 - Auxiliary Proving Switch Contacts
 - Flow Switch Contacts
 - Alarm on Any Failure Contacts
 - Runtime Contacts
 - Tank Sensor Contacts

- Cascade Contacts
- 0-10 VDC BMS External Control Contact
- 0-10 VDC Boiler Rate Output Contacts

OPTIONAL EQUIPMENT

- Alarm on Any Failure
- Condensate Neutralization Kit
- Modbus Communications
- BMS Gateway to LON or BacNet
- Freeze Protection Kit (Condensate Trap)

*Exclusive to Lochinvar

For technical information call 800-722-2101. Lochinvar, LLC reserves the right to make product changes or improvements without prior notice.



Lochinvar, LLC
300 Maddox Simpson Parkway
Lebanon, Tennessee 37090
P: 615.889.8900 / F: 615.547.1000

[f](#) [in](#) [v](#) [o](#) [i](#) [s](#) [t](#) [a](#) [r](#) [c](#) [o](#) [m](#) Lochinvar.com

