



COMMERCIAL GAS TANKLESS WATER HEATER

Introducing Lochinvar's® XCalibur® condensing commercial gas tankless water heater, delivering high efficiency, on-demand performance with the flexibility to install in practically any commercial setting. With a 96% Thermal Efficiency, a 0.95 Uniform Energy Factor (UEF), and Ultra-Low NOx emissions, the XCalibur commercial tankless heater lowers operating costs while satisfying environmental standards.

CONDENSING GAS MODELS

FEATURES:

HEAVY DUTY STAINLESS-STEEL HEAT EXCHANGER DESIGN

- Single stainless steel, heavy-duty heat exchanger design eliminates most internal welds and improves overall reliability
- More resilient to scale buildup and corrosion

PERFORMANCE & EFFICIENCY

- 199,000 BTU/h
- 9,000 BTU min. input
- 22:1 Turndown Ratio
- Max Flow Rate 10.5 GPM; 0.4 GPM activation; 0.26 GPM for continuous fire
- 0.95 UEF, ENERGY STAR® certified
- 96% Thermal Efficiency
- Temperature range 100 F (38°C) - 185°F (85°C); Default 140 F (60°C)
- Ultra Low NOx – Complies with SCAQMD Rule 1146.2*

ULTIMATE FLEXIBILITY EASE OF INSTALLATION

- Universal indoor or outdoor installation; Outdoor Vent Cap Kit sold separately

- Field convertible from Natural Gas to Liquid Propane, kit included
- 1/2" Gas Line or larger
- Exhaust venting, 2" PVC up to 75' (23 m); 3" PVC up to 150' (45.7 m)
- Cat. IV venting may be used
- Flexible venting with PVC, CPVC, Polypropylene, or ABS Pipe (solid core only)
- Common vent up to 12 units
- Outdoor rated power cord standard on every unit
- Cascade up to 32 units with single cable per heater, cable included
- Wi-Fi and Building Maintenance System (BMS) connectivity (accessory modules sold separately)
- Optional X3 Scale Prevention Technology (cartridge sold separately)

WARRANTY

- 8-year limited warranty on heat exchanger in commercial applications
- 5-year limited warranty on all parts in commercial applications

*Ultra Low NOx – Complies with SCAQMD Rule 1146.2 and other air quality management districts with similar NG NOx emission requirements of 14 ng/l or 20 ppm. Complies with SJVAPCD Rule 4308 and other air quality management districts with similar LP NOx emission requirements of 77 ppm.



Optional Outdoor Vent Cap Kit sold separately

XCALIBUR CONDENSING COMMERCIAL TANKLESS

		LCTH-199M
Installation Type		Indoor / Outdoor*
X3® Scale Prevention Technology		Optional Accessory
Thermal Efficiency		96%
Uniform Energy Factor (UEF)		0.95
Gas Consumption Input	Min. BTU/H	9,000
	Max. BTU/H	199,000
Fuel Type		Natural Gas (Field Convertible to Liquid Propane, Kit Included)
Heat Exchanger		Stainless Steel
Maximum GPM**		10.5 GPM
Activation GPM		0.4 GPM
Continuous Fire GPM		0.26 GPM
Water Pressure Min. - Max.		15 - 150 PSI (0.1 - 1 MPa); 40 PSI Recommended for Maximum Flow
Supply Gas Pressure (NG)	Min. in W.C. (kPa)	3.5 (0.9)
	Max. in W.C. (kPa)	10.5 (2.6)
Supply Gas Pressure (LP)	Min. in W.C. (kPa)	8.0 (2)
	Max. in W.C. (kPa)	13.0 (3.2)
Hot/Cold Connections		3/4" NPT
Gas Connection		1/2" NPT
Temperature Settings Min. - Max.		100°F (38°C) - 185°F (85°C); Default 140°F (60°C)
Ignition System		Electronic Ignition
Power Supply		120V, 60Hz, <5A
Sound Level		50.3 dB**
Elevation		Certified from Sea Level to 10,100' (3,078.5 m)
Freeze Protection*		- 5°F (-21°C)
Venting - Exhaust, Intake	Type	Power Direct Vent
	Size, Max Run	2", 75' (5.08 cm, 22.9 m); 3", 150' (7.6 cm, 45.7 m)
	Material	Cat. IV; PVC, CPVC, Polypropylene (Solid Core Only), Power Vent
Dimensions - Unit	Height***	33.8" (85.9 cm); with optional X3 cartridge 41.8" (106.2 cm)
	Width	16.5" (42 cm)
	Depth	16.1" (41 cm)
	Weight	102 lb. (46.3 kg)
Dimensions - Shipping****	Height	20.8" (52.7 cm)
	Width	22.3" (56.5 cm)
	Depth	40" (101.6 cm)
	Weight	117 lb. (53.1 kg)

Energy Star® certified.

* Universal install; outdoor installation requires outdoor vent cap kit (Part No. 100369060) sold separately

** Current numbers based on factory settings

***Height with required Bypass cartridge installed. From flue collar to cartridge base.

****Packaged and shipped on unit back.

+Internal freeze protection for heater only; both Bypass cartridge and X3 cartridge require anti-freeze kits sold separately

Included with Heater: Manual, Wall Mounting Bracket and Hardware, Vent Port Screws, Cascading Cable, Fuel Conversion Kit, Bird Screens

CONDENSING COMMERCIAL TANKLESS DIMENSIONS

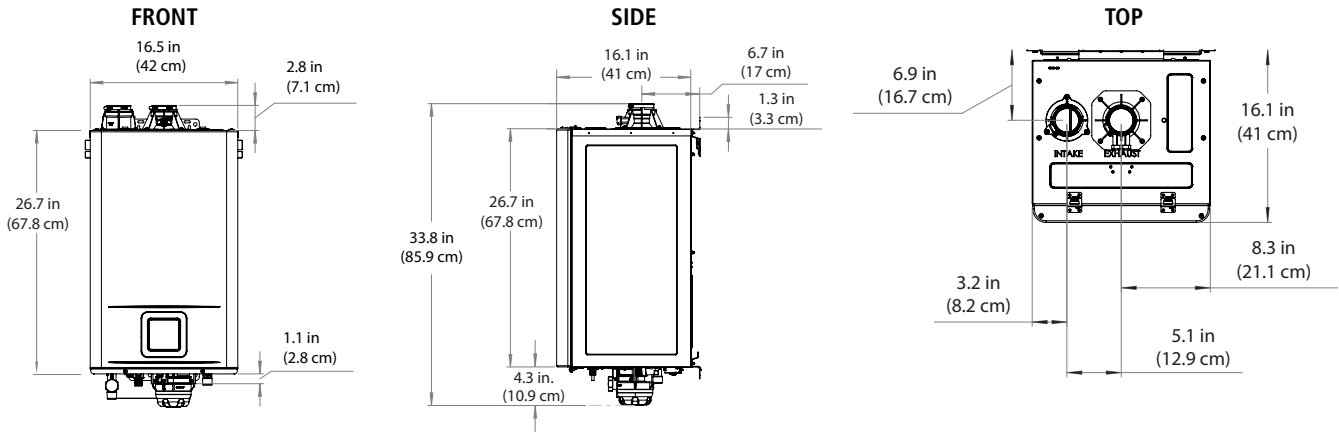

FRONT (SHOWN WITH OPT. X3 CARTRIDGE)

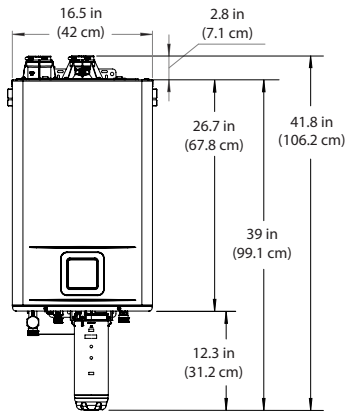

BOTTOM

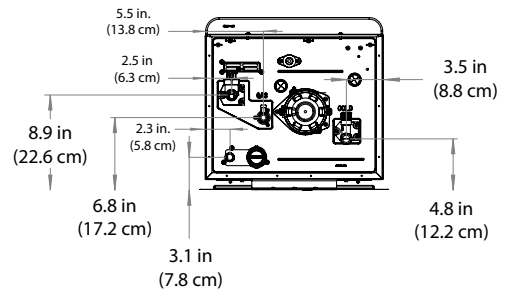



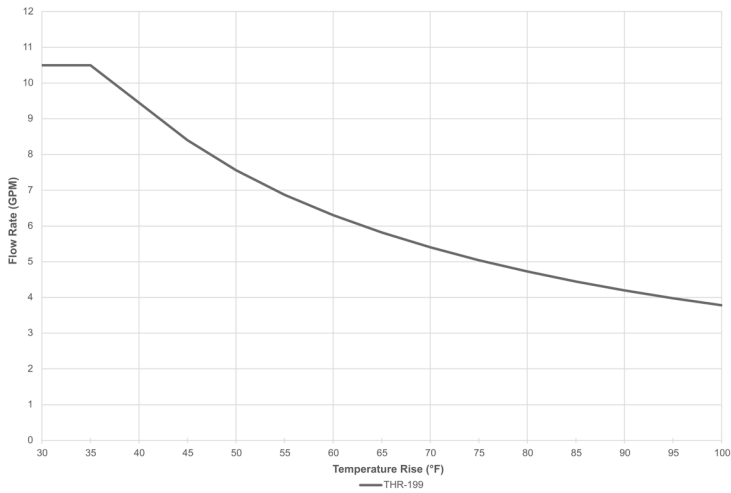



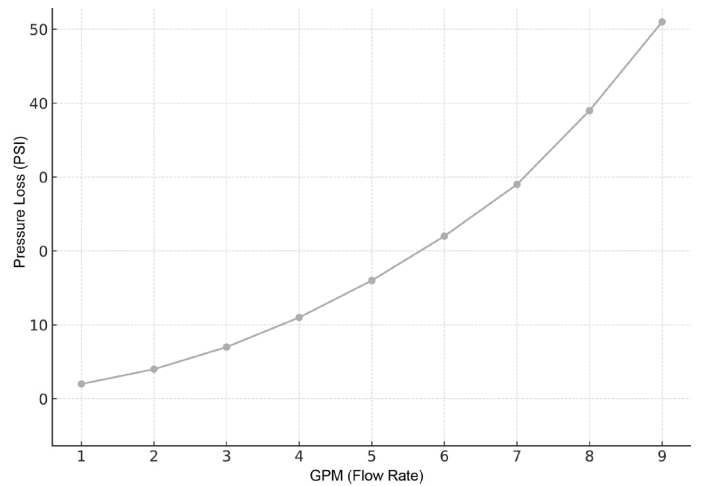

FLOW RATE CAPACITY

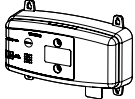
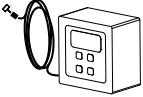
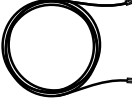
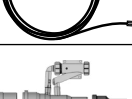
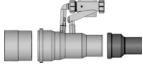

PRESSURE LOSS

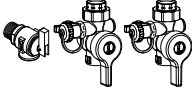

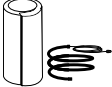
CONDENSING COMMERCIAL TANKLESS OPTIONAL ACCESSORIES

Item		Description
Wi-Fi Module Kit 100371922		Wi-Fi Module for electronically connecting tankless water heaters to the internet and adapter to connect to the water heater. <ul style="list-style-type: none"> • Module (1x) • Cable (1x) • Adapter (1x)
Remote Temperature Controller 100402144		Remote Temperature Controller with 10' (3 m) cable.
Communication Cable - 10' (3 m) 100377341		Replacement Communication Cable for Remote Temperature Controller or WIFI Module, or On-Demand Receiver, 10' (3 m).
Communication Cable - 32' (10 m) 100377342		Extended Communication Cable for Remote Temperature Controller or WIFI Module, or On-Demand Receiver, 32' (10 m).
Non-Return Vent Adapter Kit. 100402142		For common vent installations only.
Bypass Freeze Protection (M Models) 100371918		Bypass Freeze Protection can add an extra layer of freeze protection to external Bypass cartridge. Cartridge not protected by heater's internal freeze protection.
Pipe Cover 100374697		Pipe Cover protects plumbing connections to the heater while improving the appearance of the installation. Affixes to bottom of heater.
Neutralizer Assembly Kit 100112159		Neutralizer Assembly neutralizes the condensate (acidic water) that forms in the heat exchanger of the water heater. It connects to the condensate drain port of the water heater by using connectors included with the neutralizer kit.
Outdoor Vent Cap Kit 100369060		Vent cap kit and accessories for installing the tankless heater outdoors. Kit contains: <ul style="list-style-type: none"> • Vent Cap (1x) • User Interface Overlay (1x)
Isolation Valve Kit with Pressure Relief Valve 100112156		Isolation Valve supports routine maintenance and allows for draining and flushing the heater; whereas, the Pressure Relief Valve, as the name implies, serves to limit internal pressure in the system. Not necessary for X3 models. Check local codes for applicability.
X3 Cartridge 100368986		Can be installed to add an additional layer of scale prevention in extreme hard water conditions. Suitable for use in commercial applications where return water temperature does not exceed 120°F (49°C).
X3 Freeze Protection (X3 Models) 100325654		X3 Cartridge Freeze Protection can add an extra layer of freeze protection to external SCM cartridge. Cartridge not protected by heater's internal freeze protection.
Cross Over Valve Kit 100327167		For plumbing systems without a dedicated return line necessary for recirculation system functionality. Install at the faucet furthest from the hot water heater.
Product Preserver Anti-Scale System (PP-AS20) 100291509 Replacement Cartridge (PP-AS20R) 100291510		Can be installed on the cold water line upstream of the tankless heater to add an additional layer of scale prevention.

XCALIBUR CONDENSING COMMERCIAL TANKLESS SPECIFICATIONS

The fully modulating, on-demand, condensing gas fired tankless water heater(s) shall be Lochinvar model LCTH-199M, having a maximum input rating of 199,000 Btu/h and available in Natural Gas or field convertible to LP.

The heater shall provide a 96% thermal efficiency. The heater shall have a 22:1 turndown ratio capable of delivering a maximum flow rate of 10.5 GPM, with an activation flow rate of 0.4 GPM and continuous-fire capability at 0.26 GPM. The heater shall provide an output temperature range of 100°F – 185°F. The heater shall have ¾ in. male NPT water connections and ½” gas connections. The inlet gas supply pressures shall be 3.5 in. WC (min.) up to 10.5 in. WC (max) for NG and 8.0 in. WC (min.) up to 13 in. WC (max.) for LP. The operating water pressure range shall be 15-150 psi, with 40 psi recommended for maximum flow capability.

The water heater shall be suitable for installation in either indoor or outdoor locations when equipped with the manufacturer's Outdoor Vent Cap Kit. The heater(s) shall operate using 120 V / 60 Hz power source and include outdoor rated power cord. The heater(s) shall incorporate an onboard electronic control system providing temperature adjustment, safety monitoring, ignition control, system diagnostics, and communication for cascading. The heater(s) shall be capable of cascading up to 32 units using the supplied communication cable with single-cable daisy-chain connectivity. Optional Wi-fi and Building Management System modules shall be available for remote monitoring and control. The heater(s) shall include factory-installed sensors for water temperature, flow rate, combustion safety, and exhaust monitoring. Internal components shall include an electronic ignition system, stainless-steel burners, modulating gas valve, and the required high-limit temperature protections.

The indoor heater(s) shall be vented with 2” or 3” diameter Category IV vent pipe, PVC, CPVC, or Polypropylene with a length not to exceed 75 ft. (equivalent) for 2” vent or 150 ft. (equivalent) for 3” vent, terminating horizontally or vertically. Each 90-degree elbow counts as 5 feet of vent length, and each 45-degree elbow counts as 2.5 feet (maximum of 5 elbows).

The heater models are design certified by CSA according to ANSI Z21.10.3 · CSA 4.3, approved for sale in the United States, ENERGY STAR® qualified, has a minimum uniform energy factor (UEF) of 0.95, meets the energy efficiency requirements of the U. S. Department of Energy and ASHRAE 90.1, complies with SCAQMD Rule 1146.2 and other air quality districts with similar requirements for low NOx emissions of 14 ng/l or 20 ppm, and shall be certified to NSF 5 standards.

For technical information call 800-722-2101. Lochinvar, LLC reserves the right to make product changes or improvements without prior notice.



Lochinvar, LLC
300 Maddox Simpson Parkway
Lebanon, Tennessee 37090
P: 615.889.8900 / F: 615.547.1000

    Lochinvar.com

 CSA/ANSI Z21.10.3 · CSA 4.3



Complies with
SCAQMD
Rule 1146.2
California and Texas

