

Main Control Panel

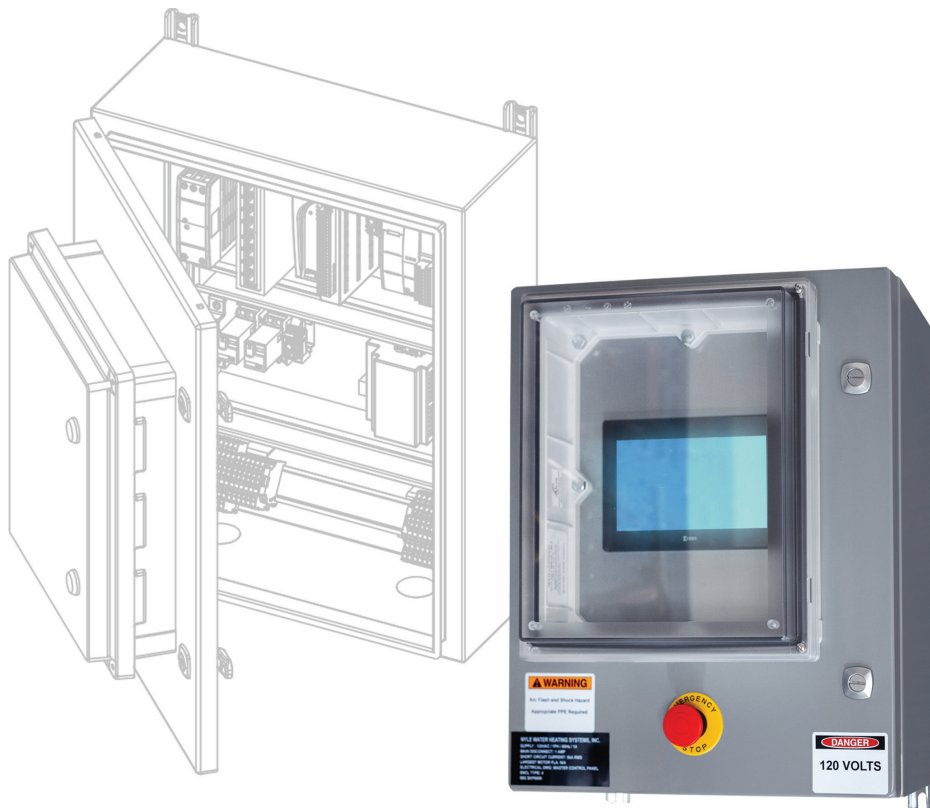

A Controller for Lochinvar Commercial Heat Pump Water Heaters

For Control Panels produced from 3/13/26 to:

IM-MCP-NWS-L260303

Installation Manual

Contents

Introduction	3	Power Wiring	8
Safety Information	3	Control Wiring	10
Precautions.....	3	Control Wiring Installation.....	10
Grounding Instructions	3	Field Wiring Control Points	11
General Description	4	Single-Pass Tank Sensors for MCPs.....	12
Purpose	4	Multi-Pass Tank Sensors for MCPs	13
Usage	4	Configuration	14
Controls and Electrical.....	4	BMS Installation and Configuration	
Electrical and Operational Specifications	5	(MCP-G Only)	14
Physical Specifications and Clearances	6	Configuration Prep and Login.....	14
Before Ordering Your MCP	7	Network Settings	15
Control Panel Installation	7	Protonode Configuration.....	15
Required Tools and Materials	7	Points List.....	16
Rough-In Checklist	7	BMS Testing	18
Transportation, Placement, Mounting.....	7	Pre-Startup Checklist	19
		Placement and Physical Checks	19
		Electrical Checks	19
		Final Checks.....	19
		Troubleshooting	20
		Limited Warranty	21

Introduction

Thank you for your purchase of a Main Control Panel from Lochinvar. The control panel is intended to synchronize the operation, interface, and staging of up to six Lochinvar commercial heat pump water heaters, allowing multiple heat pumps to work together to service larger domestic water loads.

This refreshed model has enhanced capabilities for controlling both Single and Multi-pass domestic hot water systems, and is suitable for all MHP heat pump water heaters. It is available with and without an optional BMS Gateway, for integration into BACnet[®] systems via IP or MSTP

Safety Information

The proper installation, use and servicing of this control panel is extremely important to your safety and the safety of others.

Many safety-related messages and instructions have been provided in this manual and on your own control panel to warn you and others of a potential injury hazard. Read and obey all safety messages and instructions throughout this manual. It is very important that the meaning of each safety message is understood by you and others who install, use, or service this control panel.



This is the safety alert symbol. It is used to alert you to potential personal injury hazards. Obey all safety messages that follow this symbol to avoid possible injury or death.

DANGER

Ensure control power is OFF at the control panel when wiring accessories to the unit to prevent injury or death due to electrical shock.

WARNING

To prevent inductive power transfer, do not run sensor or communication wiring in parallel with any wires carrying 120v or greater voltage power. If this is unavoidable, use shielded wire or conduit for sensor wiring.

Precautions

If the unit is exposed to the following, do not operate until all corrective steps have been made by a qualified service agency.

- Fire
- Damage
- Exposure of internal components to water

Grounding Instructions

This control panel must be grounded in accordance with the National Electrical Code and/or local codes. These must be followed in all cases. Failure to ground this control panel properly may cause erratic system operation. This control panel must be connected to a grounded metal, permanent wiring system; or an equipment grounding conductor must be run with the circuit conductors and connected to the equipment grounding terminal or lead on the control panel.

General Description

Purpose

Main Control Panels (MCPs) are central controllers that synchronize the operation of up to six attached commercial heat pump water heaters, for use in commercial domestic hot water systems.

Usage

Main Control Panels are installed as external controls to the controlled heat pumps. The MCP can then provide a central interface to control the attached heat pumps, and will monitor tank conditions to direct the staging and operation of the heat pumps for commercial domestic hot water heating, in either single-pass or multi-pass systems.

MCPs are NOT intended for space heat applications, or for heat pumps produced by companies other than Lochinvar, Inc.

Controls and Electrical

Main Control Panels require single phase, 120v power, direct wired. In addition, tank sensors are required for operation, also directly wired to the MCP. Control devices may wire to the MCP as well for specific applications. Heat pumps are connected to the MCP by ethernet cable.

MCP-G units are MODBUS and BACnet[®] capable using the included BMS Gateway, ready to be integrated into BMS systems by 3rd party integrators using BACnet/IP and BACnet MSTP protocols.

All MCP units are certified to UL508A.

For more information:

During the installation and commissioning of MCPs, it will be necessary to refer to individual heat pump manuals and tank sensor manuals for specifics on programming and placement.

Electrical and Operational Specifications

Electrical Specifications

Voltage	120/1/60
Rated Current (RLA)	1 Amp
Minimum Circuit Ampacity (MCA)	1 Amp
Maximum Overcurrent Protection (MOCP)	15 Amps
Short Circuit Current Rating (SCCR)	5 kA

Operational Specifications

Max Connected Heat Pumps	6
Maximum Connected Sensors	4x 10k NTC
Booster Pump Relay Outputs	2x 120v
Pump Relay Max Current	15 Amps VAC
Booster Pump Analog Output	1x 4-20mA or 0-10v
Booster Pump Stages	6 (Multi-pass only)

BMS Specifications (MCP-G Only)

BMS Connection Types	BACnet IP, BACnet MSTP
Baud	9600, 19200, 38400, 57600, 768000, 115200

Physical Specifications and Clearances

Physical Specifications and Ratings	
Ambient Operating Temperature	14-120 Deg. F
Ambient Operating Humidity	10-90 RH
Dimensions (in.)	16" W x 20" H x 11½" D
Weight	40 lb.
NEMA Class	4
Certifications	UL508A

Dimensions and Clearances

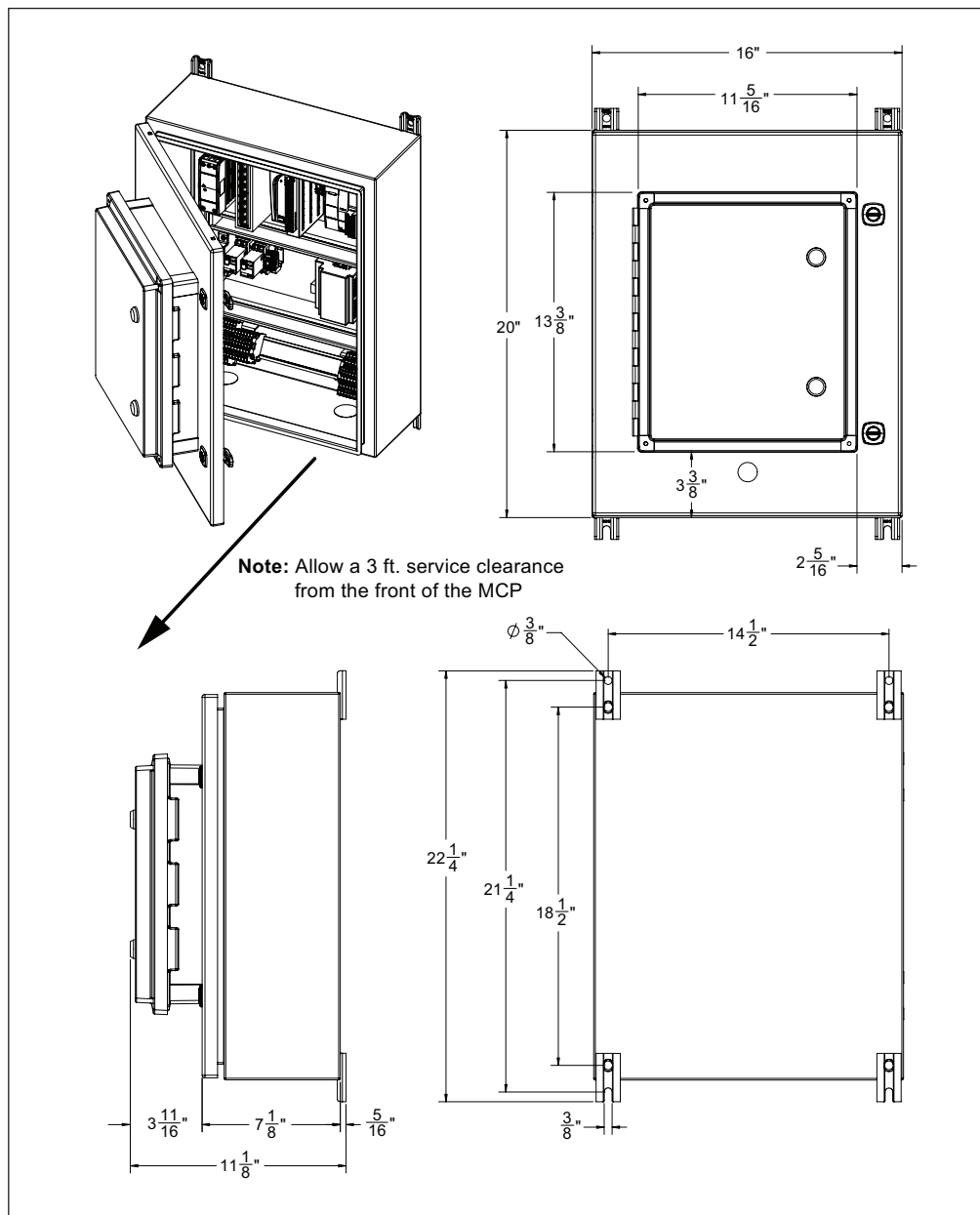

Before Ordering Your MCP

Please ensure you are ordering the correct MCP for your project!

If integration into a Building Management System (BMS) is required, please order the MCP-G variant. This avoids the need to add a BMS gateway to each individual heat pump.

If you need to control more than six individual heat pumps, consider the “Large Array” Main Control Panel (MCP-LA). Review that product’s documentation for applicability to your project.

Control Panel Installation

Required Tools and Materials

In addition to all standard tools and material required for any electrical installation and to mount the control panel, some of the other specialty tools required to support this installation include:

1. Heat transfer compound such as Honeywell part number 107408 or equivalent.
2. Electrical switch lockout devices - used to secure disconnect switches/breaker panels while servicing.
3. Electronic thermometer with range of 10°F - 210°F (-12°C - 100°C) including:
 - Sensors capable of measuring surface temperatures on water piping
4. Volt-Ohm Multimeter - capable of measuring:
 - AC Voltage up to 600 VAC
 - DC Voltage up to 24 VDC
 - Ohms up to 2,000,000 ohms
 - Continuity
 - Amperage up to 200 amps

Rough-In Checklist

Infrastructure must sometimes be installed prior to the installation of the unit. Items to consider for “rough-In” installation include:

- Ethernet cables between the control panel and all connected heat pump locations.
- Primary 120v power wiring.
- Control wires for attached devices and sensors.
- Site prep for mounting the MCP.

Please refer to the appropriate sections of the manual for the specific details associated with each item.

Transportation, Placement, Mounting

IMPORTANT!

Do not remove, cover, or deface any permanent instructions, wiring diagrams, labels, or the rating labels present on the unit. These are important for installation and service.

When Transporting the Control Panel:

1. Transport the unit with care appropriate to prevent damage to electronic devices.
2. Do not expose the panel to condensing conditions, extreme heat or extreme cold.

Placement considerations for the control panel:

- Ensure the location meets all requirements for ambient temperature, structural support, unit dimensions, operational and service clearances. See physical specifications to confirm.
- Mounting location must be structurally stable.
- Mounting location should be easily accessible for visual inspection and for regular service.
- Mounting location should ideally allow for protection from the elements during service work, which may require ladders or opening the control panel door.
- Mounting location should avoid generating temperature extremes in the panel, such as rooftop mounting in very hot environments in direct sunlight.

Mounting the Control Panel

The control panel has four anchor points to mount to a wall or vertical support structure. Use appropriate anchors or bolts to attach the panel to the mounting surface. See the dimensional drawings for the MCP to prepare properly for mounting bolt spacing and placement.

Control panels can be surface mounted directly on suitably sound wall surfaces. However, using a secondary mounting system such as unistrut can allow for improved airflow behind the unit. This can reduce risks of condensation corrosion or heat buildup in the control panel. When possible, Lochinvar recommends using spacers or mounting systems behind the control panel.

Always mount the control panel in the correct orientation. Do not mount the panel inverted or rotated from its normal orientation.

Power Wiring

WARNING

Improper handling of unit electrical power can result in immediate equipment damage, fires, injury, and death. Ensure only qualified personnel interact with main power lines. Never work while power is live; use all possible safety precautions and perform all work in accordance with appropriate local codes, National Electric Code, and/or CSA regulations.

Main Control Panels are voltage-specific, and require proper planning to provide the electrical support appropriate to each unit. Please be sure to refer to the product's electrical specifications, project documentation, and the requirements and installation instructions below.

Power Requirements:

1. Voltage is above 100v.
2. Power is clean, reliable, and well grounded.
3. Wire and breakers are appropriately sized for the load.
4. Wire and breakers are properly specified for the environment they are installed in.
5. Backup generators should include line conditioning suitable for running electronics.
6. Follow manufacturer's torque specifications for all power wire equipment by others.

Power Wiring Installation

Electricians must create their own entry points into the MCP. There are two points that require creation of an access hole, both marked with “Knock Out Hole Here” stickers. All holes should be weather tight when installation is completed.

Figure 1: Open Electrical Control Panel and Locate the Knockout Holes

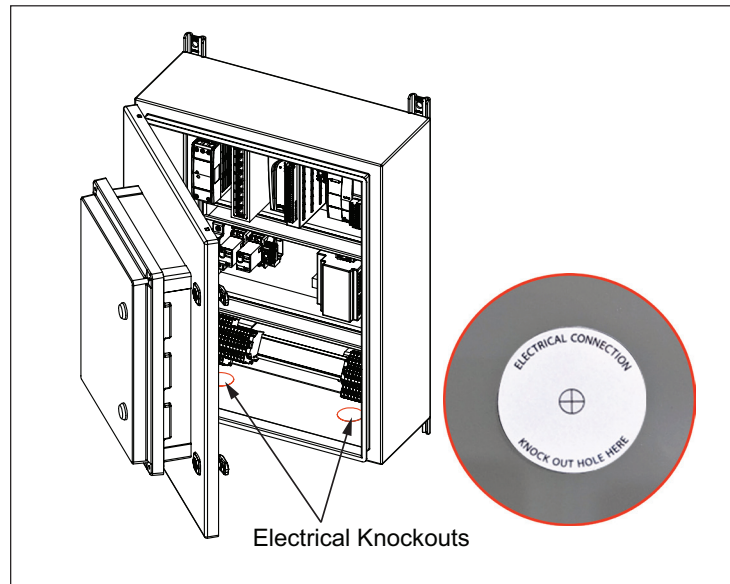

1. Ensure the control panel is powered down when making electrical connections.
2. Open the panel enclosure.
3. Create a power wire access point on the MCP: typically, following the knockout sticker guidance on the inside bottom face of the enclosure is recommended.
4. Run conduit to/through the knockouts with appropriate, weather-tight connections, and pull wire into the enclosure.
5. Make the final power wire and ground wire connections in accordance with the power wiring diagram. Use 0.5Nm of torque on wire terminals in the heat pump.
6. Tug test the new connections, and then close the electrical enclosure. It is now safe to restore power to the control panel.

Figure 2: Power Wire Connections

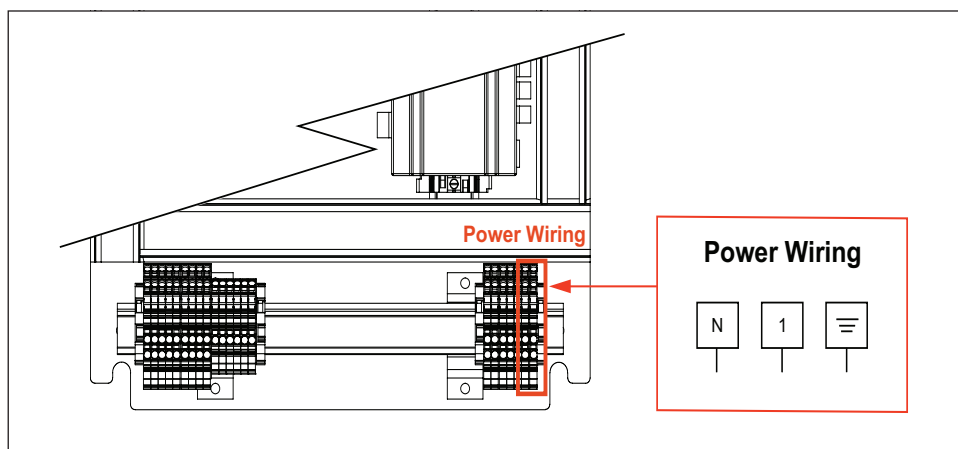

Control Wiring

Main Control Panels have several contact points for field wiring of external controls.

Lochinvar recommends running enough conductors to use all available contacts if the installation site would make wire retrofits challenging, even if those contacts are not intended for use during the initial installation. This allows changes and reconfiguration to happen seamlessly in the future. Additional conductors to allow for wire breakage, and/or the addition of future accessories, is also recommended.

The following drawing and notes provide a quick reference of the available contacts in the control panel, and what they are used for. For more advanced configuration guidance, see the Configuration section of this manual and/or instructions for any relevant accessories.

All control wiring should follow best practices, local codes and regulations, and NEC/CSA guidelines.

Do not steal power from powered contacts for external devices. Follow all ratings and wire types for the contacts detailed below.

Control Wiring Installation

1. Ensure the control panel is powered down when making electrical connections.
2. Open the panel enclosure.
3. Create a control wire access point on the MCP: typically, following the knockout sticker guidance on the inside bottom face of the enclosure is recommended.
4. Run all external sensor wires and/or control wiring for field accessories through the access point, using a weather tight connection method.
5. Once in the enclosure, wires can be attached to their target terminals. See [Figure 3](#) below for specific wiring connections.
6. Tug test the new connections, and then close the electrical enclosure. It is now safe to restore power to the control panel.

CAUTION

Contacts labeled “Dry” are intended to switch power from external sources. **DO NOT APPLY EXTERNAL POWER** to any contact that is not “Dry”. Equipment damage and system failure can result from applying power to a powered contact. Follow all power specs for each contact.

Figure 3: Control Wiring Connections

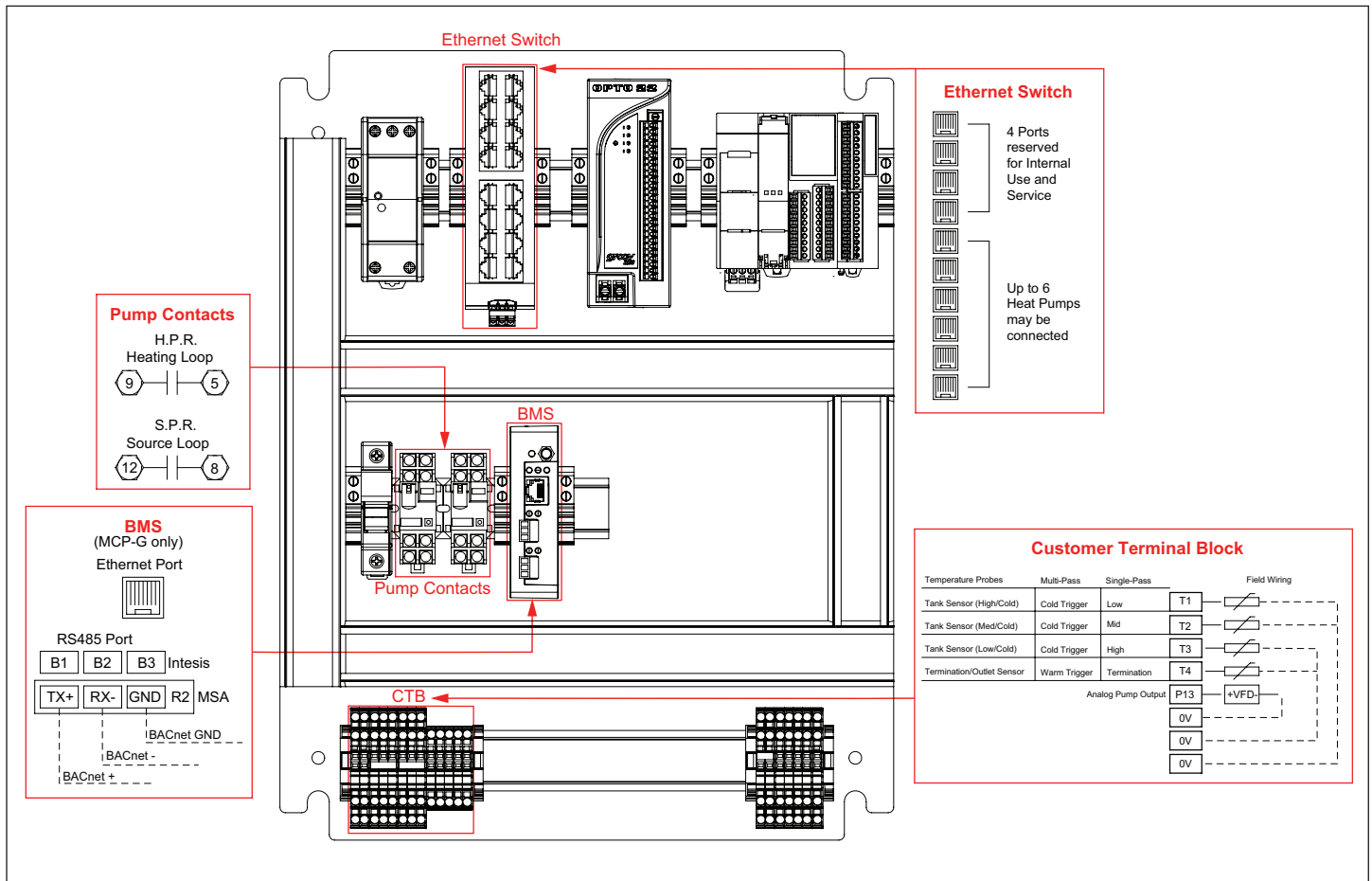

Field Wiring Control Points

Analog Pump Output: These terminals output a 0-10v or 4-20ma signal to control modulating equipment, such as an external circulator, in response to current staging demands.

BMS (MCP-G Only): The Ethernet or Serial connection used to connect to building automation systems.

Ethernet: Ethernet is used for connecting to all attached heat pumps. Each heat pump to be controlled needs to be connected to the ethernet switch. No more than six heat pumps can be connected in this way.

Pump Contacts (HPR and SPR): These dry sets of contacts close when the system is operating for a heat demand. They are intended to trigger control devices such as valves or pumps on the heating side (HPR) of the system, or the source loop side (SPR) for water source heat pumps.

Tank Sensor terminals (T1-T3): These sensor inputs allow the MCP to monitor and control the tank temperatures. Take care that the tank sensors are installed in accordance with the sensor diagrams appropriate to the type of heat pump in use, single- or multi-pass. Tank sensor behavior changes in different modes of operation. See Tank Sensor detail sections following this section.

Outlet/Termination Sensor (T4): Sensor input for single-pass demand termination, or multi-pass “Minimum Outlet” trigger in multi-tank applications. In single-tank multi-pass applications, this sensor is a “Warm Trigger” sensor. See Tank Sensor detail sections following this section.

Table 1: MCP Control Wiring Specifications

Contact	Location	Terminals		Wire Type	Power
Analog Pump Output	Analog	P13	0v	Stranded/Shielded	4-20ma
BMS ¹	RX-	TX+	G	Stranded/Shielded	Variable
Ethernet ²	(Note 2)	-	-	CAT-5 or CAT-6	-
Pump Contact HPR	Relay	9	5	Any	Dry ³
Pump Contact SPR	Relay	12	8	Any	Dry ³
Tank Sensor (High/Cold) ⁴	Analog	T1	0v	Stranded/Shielded	24Vdc
Tank Sensor (Med/Cold) ⁴	Analog	T2	0v	Stranded/Shielded	24Vdc
Tank Sensor (Low/Cold) ⁴	Analog	T3	0v	Stranded/Shielded	24Vdc
Termination/Outlet Sensor ⁴	Analog	T4	0v	Stranded/Shielded	24Vdc

Notes:

- ¹ For MCP-G Only.
- ² Ethernet Port on BMS for BACnet IP, and on switch for heat pump connections.
- ³ All Relay contacts are rated for 15A/250VAC, or 6A/28VDC max.
- ⁴ Sensor outputs vary by mode of operation. See tank sensor sections for details.

Single-Pass Tank Sensors for MCPs

Main Control Panels on single-pass DHW systems use a total of 2 or 3 tank sensors to determine how many heat pumps, or “stages”, to call to satisfy a heat demand. In addition, one pipe mounted sensor is used to terminate the demand.

Sensor placement must consider the “cold cycle volume” of all heat pumps that may run when a given sensor is triggered. This means that sensors must be placed so that at least that much water volume exists between the tank sensor in question, and the termination sensor. If a sensor will call 2 heat pumps, you will need double the “cold cycle volume” of the heat pump model in use.

For more specific information about single-pass systems, cycle volumes, and tank sensor installation, please refer to the installation manuals for your specific heat pumps, and the tank sensor installation manual.

The number of single-pass heat pumps that run for each sensor is dependent on the total number of heat pumps connected to the MCP. Stages will trigger as follows for each tank sensor:

Low Sensor: This will trigger a single stage (heat pump).

Mid Sensor: This will trigger 50% of available heat pumps, rounded up.

High Sensor: This will trigger the Max Stage Count (configurable) number of heat pumps.

Termination Sensor: After the tank sensors satisfy, the demand will continue until the termination sensor senses water at or above the cut in/cut out temperature.

Figure 4: Single-pass, Multiple Heat Pumps with Central Controller

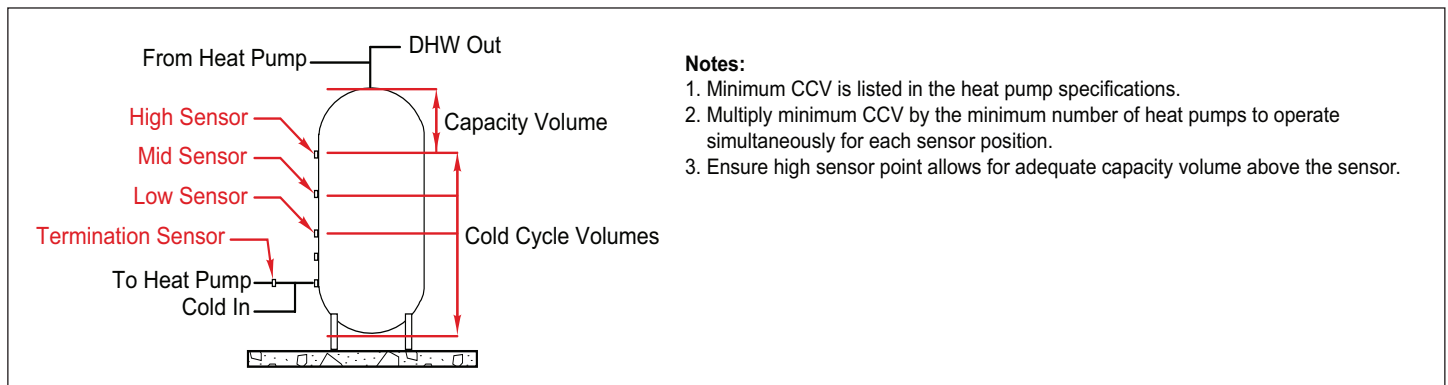

Notes:

- 1. Minimum CCV is listed in the heat pump specifications.
- 2. Multiply minimum CCV by the minimum number of heat pumps to operate simultaneously for each sensor position.
- 3. Ensure high sensor point allows for adequate capacity volume above the sensor.

Multi-Pass Tank Sensors for MCPs

Main Control Panels on multi-pass systems are set up one of two ways, depending on whether the heat pumps are serving a single tank, or multiple tanks in parallel.

On a single tank, two sensors are used: a cold trigger sensor, and a warm trigger sensor. The cold trigger sensor is positioned so there is at least the “cold cycle volume” of water between the sensor and the heat pump outlet pipe on the tank, and the warm trigger sensor is positioned so there is at least the “warm cycle volume” of water between the sensor and the heat pump outlet pipe.

On multiple-tank arrays, multiple cold trigger sensors can be used, up to a maximum of three, one in each tank. One outlet sensor is then mounted on the pipe serving hot water to the mixing valve, which will trigger a maximum stage demand if necessary.

For more specific information about multi-pass systems, cycle volumes, and tank sensor installation, please refer to the installation manuals for your specific heat pumps, and the tank sensor installation manual.

Staging in multi-pass systems is activated on time and temperature, and sensors participate in this process differently:

Cold Trigger Sensor(s): If a cold trigger sensor activates, one heat pump will run, with more heat pumps triggering over time if the sensed temperature doesn’t rise. When any cold trigger sensor is satisfied, all demands end.

Warm Trigger Sensor: If a warm trigger sensor activates, one heat pump will run. More heat pumps will trigger over time if the cold trigger sensor temperature doesn’t rise. Demands will continue until any cold trigger sensor satisfies.

Min Outlet Temperature Sensor: When a minimum outlet temperature sensor triggers, the Maximum Stage Count (configurable) number of heat pumps will run immediately.

Figure 5: Multi-pass, Single Tank Sensor Locations

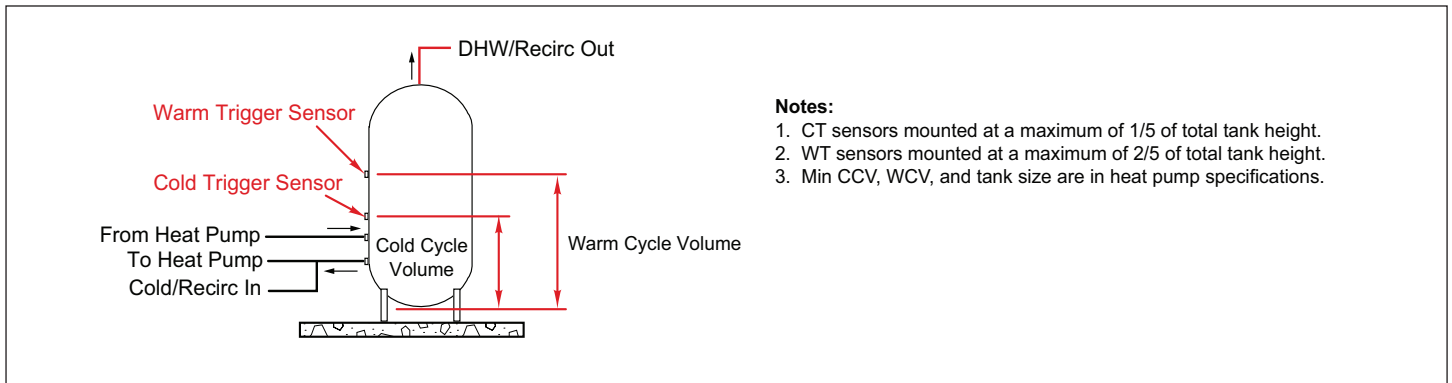
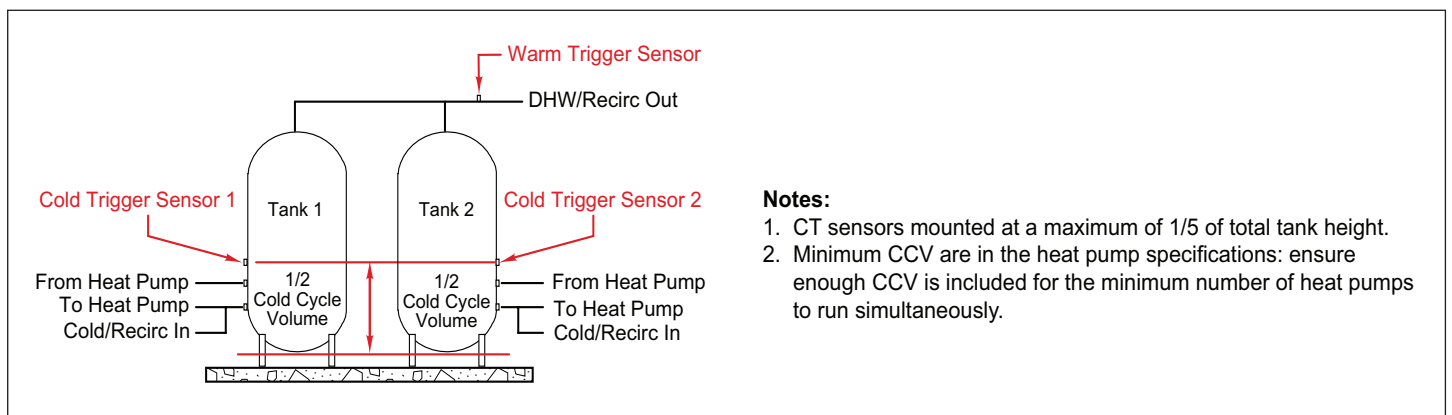

Figure 6: Multi-pass, Multiple Tanks with Central Controller



Configuration

Configuring the MCP will require active main power for the control panel, as well as on all attached heat pumps.

CAUTION

Note that while activating the main power for programming is safe, turning compressor operation “on” at this stage is not. **Complete your heat pumps’ Pre-Startup Checklist before pressing the “on” button in the control interface on any attached heat pumps!** Operating the heat pump compressor before all checks have been performed can result in severe equipment damage or major component failure.

IMPORTANT!

MCP configuration is specific to the software version installed on the control panel. A Programming and Operation Manual (POM) is included with your MCP for the software version installed in the factory; however, software can be updated on installed hardware, and software is updated and improved regularly, so the installed software on the MCP may not always match the version shipped with the controller. ALWAYS check the currently installed software version before configuration, and ensure you are using the POM for the correct software.

BMS Installation and Configuration (MCP-G Only)

WARNING

DO NOT connect the heat pump to the building network prior to gateway configuration! This will potentially overwrite the default IP address of the gateway and make finding the gateway on the network more difficult. If this occurs, it may be necessary to find the gateway on the network using the MAC address on the gateway label.

Configuration Prep and Login

1. Power up the controller, and allow it to finish its startup, before attempting to configure the BMS gateway. After startup is completed, connect a laptop directly to the gateway, using the ethernet port on the gateway. This component is shown in the “field wiring control points” diagram in the “control wiring” section of this manual, for reference.
2. Open a web browser and connect directly to <https://192.168.1.24>
 - a. You may get a “Web Server Security Unconfigured” message. It is ok to proceed with HTTPS from that warning message.
 - b. You may get a “Your Connection is not Private” message. If so, click “Advanced”, and click “proceed to 192.168.1.24 (unsafe)”.
3. Login to the gateway web interface. Username is “admin”. Password is written on the gateway’s label, and is also available via QR code on the gateway. It may be necessary to temporarily unseat the gateway from the DIN rail to read the label.
4. On the first login, the security mode will need to be set. “Basic HTTP” or “HTTPS with own trusted certificate” is recommended.

After selecting a mode, you will get a “redirecting” message, and then the Field server GUI should open.

Network Settings

1. To configure network settings, on the GUI landing page, click on the “Settings” tab. Within “Settings”, click on the “Network” tab.
 - a. On the first connection, you will get a warning message that you are about to leave the registration process. Click “Exit Registration”.
2. You should now see a page with “ETH 1” and “Routing” tabs. Click the “Routing” tab.
 - a. Select the default connection in the first row of the table.
 - b. Click the “Add Rule Button” to add a new row.
 - c. Set a new Destination Network, Netmask, and Gateway IP Address as needed.
 - d. Set the priority for each connection from 1 (highest) to 255 (lowest).
 - e. Click the “Save” button.
3. Now click the “ETH 1” tab to access the ethernet settings.

Be advised, if IP addresses are changed, you will need to reconnect to the gateway via your browser using the new IP address before you can continue with configuration settings! Only proceed once ready to connect to the building’s network.

4. DHCP to automatically accept IP settings can be enabled here, or IP settings can be manually configured.
 - a. For manual configuration, set IP Address, Netmask, Default Gateway, and Domain Name Server.
 - b. If the gateway will be connected to a router, the gateway MUST set the “Gateway” field to the IP address of the router.
5. Click “Save” to activate the settings changes.

Protonode Configuration

To configure the protonode, start from the “Device List” page in the GUI and click “Settings”.

1. Choose “Configuration”, and click the “Profiles Configuration” Button. Set the “protocol_select” field
 - a. Set to 1 for BACnet IP.
 - b. Set to 2 for BACnet MSTP.
 - c. Set to 3 for BACnet MSTP (Single Node).
 - d. Hit “submit” after entering the correct value.

Selecting a protocol will change the list of visible parameters to only parameters applicable to your protocol.

2. Set the remaining parameters according to the needs of your network and BMS system. Press “submit” to save each value.

Table 2: Configuration Parameters for BMS Gateway

Parameter	Protocol	Values	Description
protocol_select	All	1,2,3	Protocol Selector: set to 1: BACnet IP. 2: BACnet MSTP. 3: BACnet MSTP (single node).
mod_baud_rate	All	9600-19200-38400-57600	Set to the Modbus RTU baud rate required.
mod_parity	All	None,Even,Odd	Set to the Modbus parity required (Factory Set)
mod_data_bits	All	7,8	Set to the Modbus data bits required (Factory Set)
mod_stop_bits	All	1,2	Set to the Modbus stop bits required (Factory Set)
network_nr	1, 3	1 - 65535	Sets the BACnet network number for the gateway.
node_offset	1, 3	0 - 4194303	Sets the BACnet device instance (Device address plus offset).
bac_ip_port	1	1 - 65535	Set to the BACnet IP port required for the gateway.
bac_cov_option	ALL	enable, disable	Enables or Disables COVs for the BACnet application
bac_bbmd_option	1	BBMD, -	Enables or Disables BBMD for the BACnet application
bac_virt_nodes	1, 3	No, Yes	No: single heat pump on gateway. Yes: multiple heat pumps on gateway.
bac_device_id	2	1 - 4194303	Sets this BACnet device instance
bac_mac_addr	2, 3	1 - 127	Sets the BACnet MSTP MAC address
bac_baud_rate	2, 3	9600-19200-38400-76800	Sets the BACnet MSTP Baud Rate
bac_max_master	2, 3	1 - 127	Sets the BACnet MSTP max master
bac_max_info_fr	2, 3	1 - 65535	Sets max number of frames before token must be passed

3. Connect the gateway to the building network.
4. Reconnect to the new gateway IP address with your web browser, if necessary. Verify communications in accordance with the “Testing” instructions in the next section.
5. The gateway should now allow for building management system integration. Points lists for your equipment is available in a following subsection of this manual.

Points List

Following is the list of available points on the MCP-G for integration with BACnet BMS systems. Points for up to six attached heat pumps are available, in addition to the central control parameters.

Table 3: Relevant Data Points for MCP-G: Writable Values

Profile Description	Profile Name	Description of Operation
Cycle State	Cycle	Set to 1 to enable operation, 0 to disable operation.
Leaving Water Setpoint (SP) / (DR)	Lw_Set	Target leaving water temperature for single-pass operation (Deg F)
Cut-In/Out Setpoint (SP)	Cut_in_out_set	Activation/Termination temperature for single-pass operation (Deg F)
Temperature Setpoint Tank	Tank_Set	Target tank temperature (Deg F)
Cold Setpoint / Shed (DR)	Cold_Set	Activation temperature for cold sensor in multi-pass operation (Deg F)
Hot Setpoint (MP) / Loadup (DR)	Hot_Set	Activation temperature for warm sensor in multi-pass operation (Deg F)

Table 4: Relevant Data Points for MCP-G: Read-Only Values

Profile Description	Profile Name	Description of Operation
Control Mode (Local/BMS)	Display_Lock	0= Local Control. 1= BMS Control
Pump Speed	Pump_Status	0-100% readout for variable speed pump outputs.
System Cycle Status	Cycle_Status	Whether MCP-G is currently on or off
System Status (Idle / Active / Others)	System_Status	Whether heat demand is active or idle
System Alarms (MCP Generated)	System_Alarm	Communication Fault, Probe Fault, Ambient (out of operating range) faults.
Number of Installed Units	Installed_Units	The number of heat pumps the MCP is configured to operate.
Number of Units Currently Running	Running_Units	The number of heat pumps currently in active demand status.
Tank Probe 1	TankProbe1	Cold Trigger 1 (Multi-pass) / Low Sensor (Single-pass)
Tank Probe 2	TankProbe2	Cold Trigger 2 (Multi-pass) / Mid Sensor (Single-pass)
Tank Probe 3	TankProbe3	Cold Trigger 3 (Multi-pass) / High Sensor (Single-pass)
Tank Probe 4	TankProbe4	Termination sensor for single-pass operation. Warm trigger or Min Outlet sensor for multi-pass. (Deg F.)
Alarm Number Unit 1	UnitAlarm1	Alarm Status of Heat Pump 1
Alarm Number Unit 2	UnitAlarm2	Alarm Status of Heat Pump 2
Alarm Number Unit 3	UnitAlarm3	Alarm Status of Heat Pump 3
Alarm Number Unit 4	UnitAlarm4	Alarm Status of Heat Pump 4
Alarm Number Unit 5	UnitAlarm5	Alarm Status of Heat Pump 5
Alarm Number Unit 6	UnitAlarm6	Alarm Status of Heat Pump 6
Compressor Run Hours1	CompressorRunHRS1	Cumulative Run Hours for Heat Pump 1
Compressor Run Hours2	CompressorRunHRS2	Cumulative Run Hours for Heat Pump 2
Compressor Run Hours3	CompressorRunHRS3	Cumulative Run Hours for Heat Pump 3
Compressor Run Hours4	CompressorRunHRS4	Cumulative Run Hours for Heat Pump 4
Compressor Run Hours5	CompressorRunHRS5	Cumulative Run Hours for Heat Pump 5
Compressor Run Hours6	CompressorRunHRS6	Cumulative Run Hours for Heat Pump 6

BMS Testing

Good practice will include thorough verification that values reported by the heat pump match the values received in the BMS system. Ideally, this would include monitoring through an active heat demand and comparing BMS reported values to heat pump reported values.

In addition, system communication can be checked. For serial connections, check that the TX and RX LEDs are rapidly flashing.

You can also log into the field server GUI with a web browser, as in the “configuration” section. From there, clicking on “Diagnostics and Debugging”, and then on “connections”, shows you a table of communication connections. The “errors” column would indicate if there are errors requiring additional troubleshooting.

Communication errors are usually caused by:

- Baud rate, parity, data bits or stop bits set incorrectly
- Device addresses incorrect
- Wiring problems
- Device not listed in the Web Configurator
- IP Addressing incorrect.

If communication errors cannot be troubleshot, a “Diagnostic Capture” can be taken and emailed to the factory for assistance.

1. Connect to the field server GUI with your web browser
2. Click on “Diagnostics”
3. Select “Full Diagnostic”
4. Set the capture time period
5. Click start. When the capture period is finished, a download button will appear.
6. Download the capture
7. Email the capture to the factory, along with any supporting information needed to describe your problem.

Pre-Startup Checklist

The following checklist is provided for reference, to assist in preparing for the eventual startup of the equipment. Please contact your manufacturer's representative **MORE THAN ONE MONTH** from your intended startup date. The following checklist items will be reviewed for compliance before a final startup is scheduled with a factory authorized commissioning agent.

This list is Pre-Startup items specific to the MCP. Heat pumps have their own pre-startup checklists. Refer to the heat pump documentation during any pre-startup review.

CAUTION

Heat pump startups may only occur with a factory authorized commissioning agent. Do not start the heat pump before the authorized agent is on site and ready to assist, or you may void your warranty and cause equipment damage or failure.

Placement and Physical Checks

- MCP is level, stable, and securely mounted.
- MCP has appropriate service clearance, and the access panel is not obstructed by pipes, wires, or other obstacles.

Electrical Checks

- Main power wires are securely attached to the MCP and active.
- All control and communication wires are securely attached, and connected equipment is in place and ready to operate.

Final Checks

- All configuration settings are checked and correct.
- All panels and enclosures are securely closed and affixed.

Troubleshooting

Please use the following lists of startup issues, alerts and faults to assist with the diagnosis and troubleshooting of some common problems. More detailed information on alarms and other diagnostic and troubleshooting terms is available in the Programming and Operation Manual for the software version on your MCP.

In the rare event that major components end up damaged or defective, you MUST obtain assistance and approval from your rep or from Lochinvar to authorize warranty replacement, BEFORE the components are removed from service.

Problem	Check
Display Screen is Dark	Main power is active at breaker and input terminals.
	Power Supply is providing 24v power.
	Control screen is receiving power.
Configuration options don't match manual	MCP software version matches "Configuration" section in manual.
Any Heat Pumps are not visible on MCP Display	Heat pumps are set to "External" mode.
	Ethernet between HPs and MCP is good.
	Ethernet switch is on and connected to Rio.
	MCP is configured to correct number of HP's.
Heat Pumps are visible on MCP but show "Disconnected"	Heat pumps are not in initial power up phase.
	Ethernet between HPs and MCP is good.
	Ethernet switch is on and connected to Rio.
	Heat pumps are "on".
One heat pump runs, but MCP won't stage on additional heat pumps	"Max Stages" is set to high enough value.
	Tank Sensors are wired to correct terminals.
	Tank Sensors are reading correct values.
	Mix and Staging interval has been met (multi-pass only).
	Staging temp has been met (multi-pass only).
	All heat pumps show "Connected".
Heat Pumps are short cycling	LWT Set and Cut-In/Out are far enough apart (Single-pass).
	Tank Set and Trigger temps are far enough apart (Multi-pass).
Heat Pump(s) will not reach target LWT (Single-pass)	Heat pumps are configured for Single-pass.
	MCP is configured for Single-pass.
	Target LWT on MCP is set correctly.

Limited Warranty

Commercial Heat Pump Water Heater System Control Panel

1 Year Limited Warranty

Effective

For **ONE (1) YEAR**, Lochinvar® LLC warrants the commercial heat pump system control panel against failure due to defects in materials or workmanship. All Parts are warranted for **ONE (1) year** from the date of manufacture. This limited warranty is in effect when the control panel is installed within the United States or Canada, provided it remains at its original place of installation.

Warranty coverage begins on the date of installation OR 60 days after the date of manufacture if installation cannot be verified. **Note:** *The date of manufacture can be determined using the Serial Number, located on the silver rating label.* The system control panel must bear the original rating label which has not been altered, defaced, or removed, except as required by Lochinvar.

What is Covered

In the event of a defect in materials or workmanship appearing during the limited warranty period, Lochinvar will repair, or at our discretion, replace any defective part covered under this limited warranty. Any replacement part will be warranted only for the unexpired portion of the original limited warranty period.

If an identical model is no longer available due to a change in law, regulation, or standard, Lochinvar will replace the product with one having at least the same capacity and input. In these instances, you will have the option of paying the difference between what was paid for the original model and the new model with the additional features; or receiving a refund of the portion of the purchase price allocable, on a pro-rata basis, to the unexpired portion of the limited warranty period.

What is Not Covered (Problems Caused By)

- Improper connections, voltage, wiring, or fusing
- Improper installation, sizing, delivery, or maintenance
- Failure to follow printed instructions enclosed with the product
- Abuse, misuse, accident, fire, flood, Acts of God
- Failure to conduct authorized factory start up as required
- Failure to properly perform maintenance, as outlined in the instruction manuals provided by the manufacturer
- Alterations that change the intended or certified use of the product
- Failure to follow applicable local code authority having jurisdiction
- Service trips to explain proper installation, use, or maintenance of the product/control panel or to describe compliance requirements under applicable codes and regulations
- Replacement parts after expiration of this warranty
- Premium associated with after hours or overtime labor
- Any accident to the system control, any misuse, abuse or alteration of it, any operation of it in a modified form, will void this warranty



Owner's Responsibilities

Owner's Are Responsible For:

- **All labor, shipping, delivery, installation, and handling costs associated with the repair and/or replacement, including removal cost of the system control panel**
- All cost necessary or incidental for any materials and/or permits required for installation of the replacement part
- Selecting a qualified service provider. Visit www.Lochinvar.com for a list of service providers in your area
- Following all instructions provided with the product
- Retaining all bills of sale or receipts for proof of installation
- Providing copies of all service and maintenance records
- Contacting your installer or dealer as soon as any problem or defect is noticed

Limitations

NOTWITHSTANDING ANYTHING ELSE TO THE CONTRARY, THIS IS YOUR SOLE AND EXCLUSIVE WARRANTY. ALL OTHER WARRANTIES, INCLUDING A WARRANTY OF MERCHANTABILITY OR FITNESS FOR A PARTICULAR PURPOSE ARE EXPRESSLY DISCLAIMED. SELLER SHALL NOT BE LIABLE FOR ANY CONSEQUENTIAL, INCIDENTAL, SPECIAL, PUNITIVE OR OTHER INDIRECT DAMAGES. TOTAL LIABILITY ARISING AT ANY TIME SHALL NOT EXCEED THE PURCHASE PRICE PAID WHETHER BASED ON CONTRACT, TORT, STRICT LIABILITY OR ANY OTHER LEGAL THEORY.

Claim Procedure

Any claim under this warranty should be initiated with the dealer who sold the heater, or with any other dealer handling the warrantor's products. If this is not practicable, the owner should contact:

Lochinvar, LLC

300 Maddox Simpson Parkway

Lebanon, TN 37090

(615) 889-8900

Service Inquiries

For service inquiries, be prepared to provide the following information: name, address, and telephone number; the model and serial number of the water heater; proof of installation; and a clear description of the problem. For your records, fill in the product:

Serial Number: _____

Model Number: _____

