

Installation Instructions, and Use and Care Guide

RESIDENTIAL CONDENSING GAS WATER HEATERS

Power Vent / Power Direct Vent Gas Models
with Hot Surface Ignition
Series 120-121

Not For Use in Manufactured (Mobile) Homes

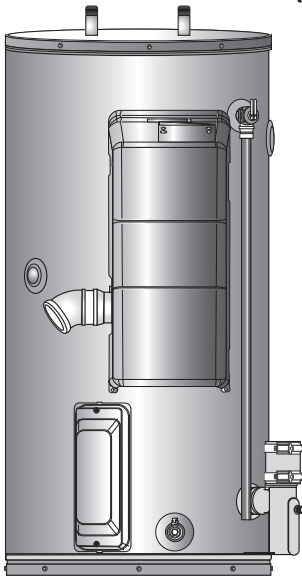

WARNING

Safety Hazard



Improper installation, operation, alteration, or service might cause a malfunction that results in property damage, personal injury, or death.

Read and understand this instruction manual and the safety messages before installing, operating, or servicing this water heater. This manual must remain with the water heater.

WARNING: If the information in these instructions is not followed exactly, a fire or explosion may result causing property damage, personal injury, or death.

- Do not store or use gasoline or other flammable vapors and liquids in the vicinity of this or any other appliance.
- **WHAT TO DO IF YOU SMELL GAS:**
 - Do not try to light any appliance.
 - Do not touch any electrical switch; do not use any phone in your building.
 - Immediately call your gas supplier from a neighbor's phone. Follow the gas supplier's instructions.
 - If you cannot reach your gas supplier, call the fire department.
- Installation and service must be performed by a qualified installer, service agency, or the gas supplier.



Place these instructions adjacent to heater and notify owner to keep for future reference.

Keep this manual in the pocket on heater for future reference whenever maintenance adjustment or service is required.

CONTENTS

<i>COMPLETED INSTALLATION (TYPICAL)</i>3	Installing the Exhaust/Condensate Tee.....24	Water System Piping.....44
<i>IMPORTANT SAFETY INFORMATION</i>4	Important Notes and Warnings.....25	Electrical Connections.....44
Do Not Operate If Damaged.....4	Power Direct Venting (PDV).....25	<i>START UP AND OPERATIONS</i>45
Hydrogen Gas Flammable.....4	Direct Vent Air Intake Moisture Protection.....25	Start Up Conditions.....45
Limiting the Risk of Scalding.....4	Termination Clearances Sidewall Power Vent.....26	Smoke/Odor.....45
Warning Messages.....5	Side Wall Vent Termination (Standard).....27	Prior to Start up.....45
Risks During Installation and Maintenance.....6	Roof Vent Termination (Standard).....27	Filling the Water Heater.....45
Risks During Operation.....6	Side Wall Vent For Cold Climates.....27	Initial Start Up.....45
Water Contamination Risk.....7	Concentric Vent Termination.....27	Required Test Equipment.....45
Fire Risk.....7	Multiple Concentric Vent Termination.....28	Preparation.....45
Explosion Risk.....7	Low Profile Vent Installation.....29	Lighting The Water Heater.....46
Carbon Monoxide Risk.....8	Calculating Equivalent Feet (PDV).....30	<i>TEMPERATURE REGULATION</i>47
<i>INTRODUCTION</i>10	Installing a New Tee Termination.....31	Temperature Control.....47
Abbreviations Used.....10	Installing a New 90° Termination.....31	Hot Water Can Scald.....47
Qualifications.....10	Power Vent (PV).....31	High Temperature Applications.....48
Qualified Installer or Service Agency.....10	Termination Clearances Other than Sidewall Direct Vent.....32	High Temperature Limit Control (ECO).....48
Important Definitions.....10	Calculating Equivalent Feet (PV).....34	<i>CONTROL SYSTEM OPERATION</i>49
Preparing For Installation.....11	Vent Installation.....34	Icons.....49
<i>MASSACHUSETTS INSTALLATION REQUIREMENTS</i>12	Condensate (Exhaust).....34	Buttons.....49
<i>FEATURES AND COMPONENTS</i>13	<i>INSTALLING THE WATER HEATER</i>35	ON/OFF.....49
Model Characteristics.....15	Water Line Connections.....35	Lock/Unlock.....49
Controls and Switches.....15	Thermostatic Point-of-Use Mixing Valves.....35	Temperature Setpoint.....49
Control Module.....15	Closed Water Systems.....36	Normal Mode / Vacation Mode.....49
Pressure Switches.....15	Thermal Expansion.....36	Burner In Operation.....49
Outlet Air Pressure Switch (OAPS).....15	Temperature-Pressure Relief Valve.....37	Switching Between Temperature Units.....49
Intake Air Pressure Switch (IAPS).....15	T&P Valve Discharge Pipe.....37	Fault Indication.....49
Hot Surface Igniter (HSI).....15	Space Heating Applications.....38	Service Mode.....49
Flame Sensor.....15	Combo Heating.....38	<i>MAINTENANCE</i>50
<i>GETTING STARTED</i>16	System Requirements.....38	Venting System Inspection.....50
Before you Begin.....16	Combo Heating Installation.....39	Draining and Flushing.....50
Recommended Accessories.....16	Electrical Installation.....39	Draining the Storage Tank.....50
Rough-In Dimensions.....17	Grounding Instructions.....39	Flushing the Storage Tank.....50
Verify that Your Home is Equipped and Up-To-Date for Proper Operation.....18	Electrical Supply.....39	Sediment Removal.....51
Water Pressure.....18	Dedicated Power Wiring and Breakers.....39	Lime Scale Removal.....51
Water Pressure Increase Caused by Thermal Expansion.....18	Power Fluctuations and Electrical Noise.....39	Chemical Lime Scale Removal.....51
Water Pipe and Tank Leaks.....18	Electrical Wiring.....40	Burner Operation And Inspection.....51
Water Temperature Regulation.....18	Making the Electrical Connections.....40	Combustion Chamber And Burner Cleaning.....51
Verify that the Location is Appropriate.....19	Gas Supply System Installation.....40	Housekeeping.....52
Removing the Old Water Heater.....20	Gas Supply Regulator.....40	Maintain Minimum Clearances.....52
Combustion Air and Ventilation.....21	Gas Line Installation.....41	Anode Rod Maintenance.....52
Corrosion and Water Quality.....21	Gas Line Sizing.....42	Temperature-Pressure Relief Valve Test.....52
Install Shut-Off and Thermostatic Mixing Valves.....21	Gas Supply Line Leak Testing.....43	Service.....53
<i>INSTALLING THE VENT SYSTEM</i>22	Gas Supply Line Purging.....43	<i>TROUBLESHOOTING</i>54
Planning the Vent System.....22	Water Heater Gas Leak Testing.....43	Service Mode.....54
Vent Kit.....22	High Altitude Installations.....43	Outlet Air Pressure Switch (OAPS).....54
Vent Pipe Material.....23	Connecting the Water Supply.....43	Intake Air Pressure Switch (IAPS).....54
Vent Pipe Length and Sizing.....23	Installation Checklist.....44	Basic Sequence Of Operation.....55
Polypropylene Vent Systems.....23	Water Heater Location.....44	Call for Heat:.....55
Vent Pipe Runs.....24	Gas Supply And Piping.....44	Monitor Flame Current.....55
Vent Pipe Installation.....24	Vent Pipe System.....44	Burner Ignition Sequence.....55
Vent Screens.....24	Vent Termination.....44	Water Leak Detection.....55
	Vertical44	Clearing Error Codes.....56
		Error Priority.....57
		Checking for leaks.....57
		<i>DIAGRAMS</i>58
		Wiring Diagram.....58
		<i>SERVICE PARTS LIST</i>59

COMPLETED INSTALLATION (TYPICAL)

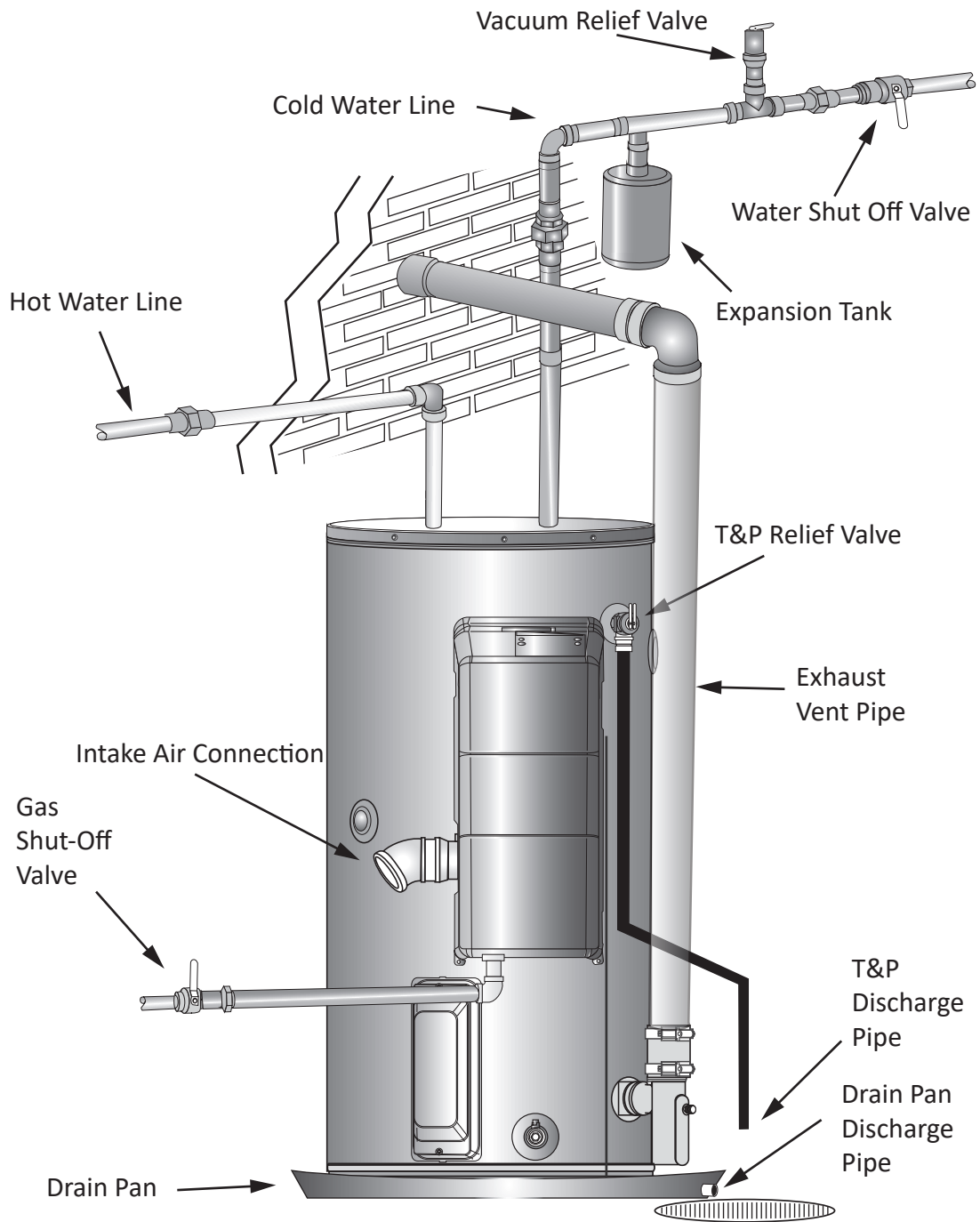

Figure 1. Typical Installation

IMPORTANT SAFETY INFORMATION

To reduce the risk of property damage, serious injury or death, read and follow the precautions below, all labels on the water heater, and the safety messages and instructions throughout this manual.

DO NOT OPERATE IF DAMAGED

DO NOT USE THIS WATER HEATER IF ANY PART HAS BEEN EXPOSED TO FLOODING OR WATER DAMAGE. Immediately call a qualified service agency to inspect the water heater and to make a determination on what steps should be taken next.

If the unit is exposed to the following, do not operate heater until all corrective steps have been made by a qualified service agency.

1. External fire.
2. Damage.
3. Firing without water.

HYDROGEN GAS FLAMMABLE

Hydrogen gas can be produced in a hot water system served by this water heater that has not been used for a long period of time (generally two weeks or more). Hydrogen gas is extremely flammable. To reduce the risk of injury under these conditions, it is recommended that a hot water faucet served by this water heater be opened for several minutes before using any electrical appliance connected to the hot water system. If hydrogen is present there will probably be an unusual sound such as air

escaping through the pipe as the water begins to flow. **THERE SHOULD BE NO SMOKING OR OPEN FLAME NEAR THE FAUCET AT THE TIME IT IS OPEN.**

⚠ WARNING

Explosion Hazard

 Hydrogen gas can accumulate in water pipes that have been unused for several days. If there is an ignition source near the faucet when you turn it on, it could ignite the hydrogen and cause an explosion.

Keep all ignition sources away from the faucet when turning on hot water.

LIMITING THE RISK OF SCALDING

For a variety of reasons, water heaters can produce water that is much hotter than its temperature setting. Take precautions to prevent this higher temperature water from reaching the water fixtures.

⚠ DANGER

Burn Hazard

 Higher temperatures over 120°F (49°C) can cause severe burns instantly resulting in severe injury or death.

To reduce the risk of unusually hot water reaching the fixtures in the house, install thermostatic mixing valves at each point of use.

According to a national standard (*ASSE 1070*) and many local plumbing codes, the water heater's gas control valve should not be used as the sole means to regulate water temperature and avoid scalds.

A properly adjusted thermostatic mixing valve at each point of use allows you to set the tank temperature to a higher setting without increasing risk of scalds. A higher temperature setting allows the tank to provide much more hot water and can help provide proper water temperatures for appliances such as dishwashers and washing machines.

Higher tank temperatures (140°F) also kill bacteria that cause a condition known as "smelly water" and can reduce the levels of bacteria that cause water-borne diseases.

IMPORTANT SAFETY INFORMATION



WARNING MESSAGES

Read and follow all safety messages and instructions in this manual.

Related messages and instructions have been provided in this manual and on your own water heater to warn you and others of a potential injury hazard. Read and obey all safety messages and instructions throughout this manual. It is very important that the meaning of each safety message is understood by you and others who install, use or service this water heater.

Many safety-related messages and instructions have been provided in this manual and on your own water heater to warn you and others of a potential injury hazard. Read and obey all safety messages and instructions throughout this manual. It is very important that the meaning of each safety message is understood by you and others who install, use, or service this water heater.

	<p>This is the safety alert symbol. It is used to alert you to potential personal injury hazards. Obey all safety messages that follow this symbol to avoid possible injury or death. Keep this manual near the water heater.</p>
---	---

 DANGER	<p>DANGER indicated an imminently hazardous situation which, if not avoided, will result in injury or death.</p>
 WARNING	<p>WARNING indicates a potentially hazardous situation which if not avoided could result in injury or death.</p>
 CAUTION	<p>CAUTION indicates a potentially hazardous situation which, if not avoided, could result in minor or moderate injury.</p>
CAUTION	<p>CAUTION used without the safety alert symbol indicates a potentially hazardous situation which, if not avoided could result in property damage</p>

All safety messages will generally tell you about the type of hazard, what can happen if you do not follow the safety message, and how to avoid the risk of injury.

Important information to keep	
Fill out this section and keep this manual in the pocket of the water heater for reference.	
Date Installed:	
Model Number:	
Serial Number:	
Maintenance Performed:*	Date
*Drain and flush tank and remove and inspect anode rod after first six months of operation and at least annually thereafter. Operate the Temperature and Pressure Relief Valve (T&P) annually and inspect T&P valve every 2-4 years (see the label on the T&P valve for maintenance schedule). If no label is attached to the T&P Relief Valve, follow the instructions in the T&P Relief Valve Maintenance section of this manual. See the Maintenance section for more information about maintaining this water heater.	

IMPORTANT SAFETY INFORMATION

To reduce the risk of property damage, serious injury or death, read and follow the precautions below, all labels on the water heater, and the safety messages and instructions throughout this manual.

RISKS DURING INSTALLATION AND MAINTENANCE

⚠ WARNING

DO NOT RETURN THIS UNIT TO THE STORE.

Read this manual and the labels on the water heater before you install, operate, or service it. If you have difficulty following the directions, or aren't sure you can safely and properly do any of this work yourself:

- Call our Technical Assistance Hotline at 1-877-817-6750 or visit <http://www.AOSmithAtLowe.com>. We can help you with installation, operations, troubleshooting, or maintenance. Before you call, write down the model and serial number from the water heater's data plate.
- Incorrect installation, operation, or service can damage the water heater, your house and other property, and present risks, including fire, scalding, electric shock, and explosion, causing serious injury or death.

⚠ WARNING

Electrical Shock Hazard

 Contact with wiring or electrical connections can result in electrical shock, resulting in severe injury, or death.

Do the following to avoid this hazard:

- Disconnect power by opening the circuit breaker or removing the fuses before installing or servicing.
- Use a non-contact circuit tester to confirm that power is off before working on or near any electrical parts.
- Replace the junction box cover and access doors after servicing.

⚠ WARNING

Lift Hazard

 This water heater is too heavy to be carried safely by one person. Attempting to do so could cause serious injury.

Avoid this hazard by doing the following:

- Use at least two people to lift the water heater.
- Be sure you both have a good grip before lifting.
- Use an appliance dolly or hand truck to move the water heater.

⚠ WARNING

Fire and Explosion Hazard

 The water heater is designed for a specific type of gas, a specific gas pressure, and a specific firing rate. Changing any of these parameters might cause the water heater to explode and catch fire, resulting in property damage, personal injury, or death.

Do the following to avoid these hazards:

- Do not connect a natural gas water heater to an L.P. gas supply.
- Do not connect an L.P. gas water heater to a natural gas supply.
- Use a pressure reducer valve to match gas supply line pressure to the water heater's rated pressure.
- Use a new CSA approved gas supply line.
- Under no circumstances should the input exceed the rate shown on the water heater's rating label.
- Install a shut-off valve on the gas supply line.
- Read the instruction manual before installing, using, or servicing the water heater.
- Contact a qualified installer or service agency for installation and service.

RISKS DURING OPERATION

⚠ DANGER

Burn Hazard

 Water temperature over 125°F (52°C) can cause severe burns instantly resulting in severe injury or death.

Observe the following precautions to avoid this hazard:

- Children, the elderly, and the physically or mentally disabled are at highest risk for scald injury.
- Feel water before bathing or showering.
- Temperature limiting devices, such as thermostatic point-of-use mixing valves must be installed when required by codes and to ensure safe temperatures at fixtures.
- The thermostat(s) on this water heater has been factory set to approximately 120°F to reduce the risk of scalding. Higher temperatures increase the risk of scalding, but even at 120°F, hot water can scald. If you choose a higher temperature, thermostatic mixing valves, located at each point-of-use are particularly important to help avoid scalding.
- Thermostatic mixing valves located at each point of use are particularly important to avoid scalding.

Table 1. Burn Time at Various Temperatures

Water Temperature °C (°F)	Time for 1st Degree Burn (Less Severe Burns)	Time for Permanent Burns 2nd & 3rd Degree (Most Severe Burns)
43 (110)	(shower temp.)	
47 (116)	(pain threshold)	
47 (116)	35 minutes	45 minutes
50 (122)	1 minute	5 minutes
55 (131)	5 seconds	25 seconds
60 (140)	2 seconds	5 seconds
65 (149)	1 second	2 seconds
68 (154)	instantaneous	1 second

(U.S. Government Memorandum, C.P.S.C., Peter L. Armstrong, Sept. 15, 1978)

For more information about changing the factory temperature setting, see *Temperature Regulation* (page 47).

Even if you set the water heater's temperature control to a low setting, higher water temperatures may occur in certain circumstances.

- In some cases, repeated small draws of water can cause the hot and cold water in the tank to "stack" in layers. If this happens, the water can be as much as thirty degrees hotter than the temperature control setting. This temperature variation is the result of your usage pattern and is not a malfunction.
- Water temperature will be hotter if someone adjusted the temperature control to a higher setting.
- Problems with the gas control valve or other malfunctions may result in higher than expected water temperatures.
- If the water heater is in a hot environment, the water in the tank can become as hot as the surrounding air, regardless of the temperature setting.
- If the water supplied to the water heater is pre-heated (by a solar heating system) the temperature in the tank may be higher than the water heater's temperature setting.
- Should overheating occur or the burner fail to shut off, turn off the manual gas supply valve to the water heater and call a qualified person.

IMPORTANT SAFETY INFORMATION

⚠ WARNING
Burn Hazard

 Higher temperatures over 120°F (49°C) can cause severe burns instantly resulting in severe injury or death.

To reduce the risk of unusually hot water reaching the fixtures in the house, install thermostatic mixing valves at each point of use.

If anyone in your home is at particular risk of scalding (for example, the elderly, children, or people with disabilities) or if there is a local code or state law requiring a certain water temperature at the hot water tap, these precautions are particularly important.

According to a national standard *American Society of Sanitary Engineering (ASSE 1070)* and most local plumbing codes, the water heater's thermostat should not be used as the sole means to regulate water temperature and avoid scalds.

Properly adjusted **thermostatic mixing valves** installed at each point-of-use allow you to set the tank temperature to a higher setting without increasing the risk of scalds. A higher temperature setting allows the tank to provide much more hot water and can help provide proper water temperatures for appliances such as dishwashers and washing machines. Higher tank temperatures (140°F) also kill bacteria that cause a condition known as "smelly water" and can reduce the levels of bacteria that cause water-borne diseases.

⚠ WARNING
Burn Hazard

 This water heater's venting system can become hot enough to burn.

Do not touch the venting system while water heater is on, or until the water heater is turned off and venting allowed to cool.

Water Contamination Risk

⚠ WARNING
Toxic Chemical Hazard

 Connecting the water heater to a non-potable water system might result in chemical or biological contamination of the water heater.

Do not connect the water heater to a non-potable water system.

Fire Risk

To reduce the risk of a fire that could destroy your home and seriously injure or kill people, read and observe the following warning messages:

⚠ WARNING
Fire and Explosion Hazard

 Contaminants in gas lines can cause fire or explosion.

Do the following to avoid this hazard:

- Clean all gas piping before installation.
- Install sediment trap in accordance with *NFPA54* or *CSA-B1491*.
- Be sure the junction box cover and the access door covers are in place.
- These covers keep debris from entering and potentially being ignited, and help keep any internal fires from spreading.

⚠ CAUTION
Property Damage Hazard

 Improper installation of electrical connections can cause the water heater to catch fire.

Do the following to avoid this hazard:

- Make electrical connections properly, according to the instructions.
- Use 10 gauge solid copper wire.
- Use a UL listed or CSA approved strain relief.
- Connect ground wire to green ground screw.

⚠ WARNING
Fire and Explosion Hazard

 Under certain conditions, the water heater can explode and catch fire, resulting in property damage, personal injury, or death.

Do the following to avoid these conditions:

- Do not store or use gasoline or other flammable vapors and liquids in the vicinity of this or any other appliance.
- Avoid all ignition sources if you smell gas.
- Do not expose water heater controls to excessive gas pressure.
- Use only the gas shown on the water heater rating label.
- Maintain required clearances to combustibles.
- Keep ignition sources away from faucets after extended periods of non-use.

⚠ WARNING
Fire and Explosion Hazard

 Exposure to water or flood conditions can cause the water heater to catch fire or explode.

- Keep the water heater from becoming wet. Immediately shut the water heater off and have it inspected by a qualified person if you find that the wiring, thermostat(s) or surrounding insulation has been exposed to water in any way (e.g., leaks from plumbing, leaks from the water heater itself can damage property and could cause a fire risk).
- If the water heater is subjected to flood conditions or the thermostat(s) have been submerged in water, the entire water heater must be replaced.
- Make electrical connections properly, according to these instructions. Use 10 gauge solid copper wire. Use a UL listed or CSA approved strain relief.

EXPLOSION RISK

⚠ CAUTION
Property Damage Hazard

 High temperature or pressure in the water heater can cause the water heater to explode resulting in severe injury or death.

- A properly sized temperature-pressure relief valve must be installed in the opening provided.
- The temperature-pressure relief valve must comply with *ANSI Z21.22-CSA4.4* and *ASME* code.
- Do not plug, block, or cap the discharge line.

IMPORTANT SAFETY INFORMATION

A nationally recognized testing laboratory maintains public inspection of the valve production process and certifies that it meets the requirements for *Relief Valves for Hot Water Supply Systems, ANSI Z21.22*. The T&P Relief Valve's relief pressure must not exceed the working pressure rating of the water heater as stated on the rating plate.

Maintain the T&P Relief Valve properly. Follow the maintenance instructions provided by the manufacturer of the T&P Relief Valve (label attached to T&P Relief Valve). If no label is attached to the T&P Relief Valve, follow the instructions in *Temperature-Pressure Relief Valve Test* (page 52). An explosion could occur if the T&P Relief Valve or discharge pipe is blocked. Do not cap or plug the T&P Relief Valve or discharge pipe.

 **WARNING**

Explosion Hazard



Hydrogen gas can accumulate in water pipes that have been unused for several days. If there is an ignition source near the faucet when you turn it on, it could ignite the hydrogen and cause an explosion.

Keep all ignition sources away from the faucet when turning on hot water.

CARBON MONOXIDE RISK

 **WARNING**

Breathing Hazard-Carbon Monoxide Gas



An improperly installed water heater can emit carbon monoxide. Breathing carbon monoxide can cause brain damage or death.

Do the following to avoid carbon monoxide poisoning:

- Install the water heater in accordance with the instruction manual and NFPA 54.
- To avoid injury, combustion and ventilation air must be taken from outdoors.
- Do not place chemical vapor emitting products near water heater.

 **CAUTION**

Property Damage Hazard

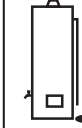

Over time, the tank and fittings of the water heater can begin to leak and cause water damage.

Locate the water heater in an area where water leakage from the heater or connections will not result in damage to the area or the lower floors of the structure.

 **CAUTION**

Property Damage Hazard



Improper installation use and service could result in property damage.

This unit must be configured with both an air intake terminal and an exhaust terminal.

 **WARNING**

Safety Hazard



Improper installation, operation, alteration, or service might cause a malfunction that results in property damage, personal injury, or death.

Read and understand this instruction manual and the safety messages before installing, operating, or servicing this water heater. This manual must remain with the water heater.

 **WARNING**

Breathing Hazard-Carbon Monoxide Gas



Operating this water heater at altitudes above 10,100 feet (3,078 m) can cause it to emit carbon monoxide. Breathing carbon monoxide can cause brain damage or death.

Consult with A. O. Smith for installations above 10,100 feet (3,078 m).

 **WARNING**

Breathing Hazard-Carbon Monoxide Gas



Certain abnormal conditions can cause the water heater to emit carbon monoxide. Breathing carbon monoxide can cause brain damage or death.

Do the following to prevent these abnormal conditions:

- Do not operate water heater if any part has been exposed to flooding or water damage.
- Do not operate if soot buildup is present.
- Do not obstruct water heater air intake with insulating jacket.
- Do not place chemical vapor emitting products near water heater.
- Never operate the heater unless it is vented to the outdoors and has adequate air supply to avoid risks of improper operation, fire, explosion, or asphyxiation.
- Always read and understand the instruction manual.
- Install gas and carbon monoxide detectors in the vicinity of the water heater.

 **WARNING**

Breathing Hazard-Carbon Monoxide Gas



An improperly installed or malfunctioning condensate drain can cause the water heater to emit carbon monoxide. Breathing carbon monoxide can cause brain damage or death.

Do the following to avoid carbon monoxide poisoning:

- Install vent system in accordance with local codes.
- Do **NOT** elevate any portion of the field supplied drain line beyond the 1/2" adapter above the adapter. This must be true for the entire length of the drain line including the exit into an appropriate drain.
- Condensate lines must be free and clear of debris and must not allow back flow through the hose. The condensate lines must be able to flow freely to an appropriate drain.
- Do not allow condensate lines to become crimped closed.
- Analyze the entire vent system to make sure that condensate will not become trapped in a section of vent pipe and therefore reduce the open cross sectional area of the vent.
- Do not install any external condensate trap. The exhaust tee assembly has an internal condensate trap.
- Install gas and carbon monoxide detectors in the vicinity of the water heater.

 **WARNING**

Fire and Explosion Hazard



Under certain circumstances, the water heater can explode and catch fire, resulting in property damage, personal injury, or death.

Do the following to avoid these conditions:

- Do not store or use gasoline or other flammable vapors and liquids in the vicinity of this or any other appliance.
- Avoid all ignition sources if you smell gas.
- Do not expose water heater controls to excessive gas pressure.
- Use only the gas shown on the water heater rating label.
- Maintain required clearances to combustibles.
- Keep ignition sources away from faucets after extended periods of non-use.
- Install sediment trap in accordance with NFPA54 or CSA-B1491.
- Read the instruction manual before installing, using, or servicing the water heater.
- Contact a qualified installer or service agency for installation and service.

IMPORTANT SAFETY INFORMATION

CAUTION

Property Damage Hazard



Solvent cements and primers for plastic pipe are flammable liquids and emit flammable vapors. Improper use can cause an explosion and fire that would result in property damage.

- Use only in well ventilated areas.
- Do not use near any open flame and all ignition sources, including water heaters.
- Use only the solvent cement and primer appropriate for the venting material being used.

WARNING

Breathing Hazard-Carbon Monoxide Gas



Installing the vent screen improperly or installing the wrong screen can cause the water heater to emit carbon monoxide. Breathing carbon monoxide can cause brain damage or death.

Install the appropriate screen designed for this water heater according to the manual and all applicable codes.

INTRODUCTION

Thank You for purchasing this water heater. Properly installed and maintained, it should give you years of trouble free service.

ABBREVIATIONS USED

Abbreviations found in this Instruction Manual include:

- ANSI - American National Standards Institute
- ASME - American Society of Mechanical Engineers
- AHRI - Air-Conditioning, Heating and Refrigeration Institute
- NEC - National Electrical Code
- NFPA - National Fire Protection Association
- UL - Underwriters Laboratory
- CSA - Canadian Standards Association

QUALIFICATIONS

Qualified Installer or Service Agency

Installation and service of this water heater requires ability equivalent to that of a Qualified Agency (as defined by ANSI below) in the field involved. Installation skills such as plumbing, air supply, venting, gas supply and electrical supply are required in addition to electrical testing skills when performing service.

ANSI Z223.1 2006 Sec. 3.3.83: “Qualified Agency” - “Any individual, firm, corporation or company that either in person or through a representative is engaged in and is responsible for (a) the installation, testing or replacement of gas piping or (b) the connection, installation, testing, repair or servicing of appliances and equipment; that is experienced in such work; that is familiar with all precautions required; and that has complied with all the requirements of the authority having jurisdiction.”

If you are not qualified (as defined by ANSI above) and licensed or certified as required by the authority having jurisdiction to perform a given task do not attempt to perform any of the procedures described in this manual. If you do not understand the instructions given in this manual do not attempt to perform any procedures outlined in this manual.

IMPORTANT DEFINITIONS

Qualified Installer: A qualified installer must have ability equivalent to a licensed tradesman in the fields of plumbing, air supply, venting and gas supply, including a thorough understanding of the requirements of the *National Fuel Gas Code, ANSI Z223.1/NFPA 54* as it relates to the installation of gas fired

water heaters. The qualified installer must also be familiar with the design features and use of flammable vapor ignition resistant water heaters and have a thorough understanding of this Installation and Operating manual.

Service Agency: A service agency also must have ability equivalent to a licensed tradesman in the fields of plumbing, air supply, venting and gas supply, including a thorough understanding of the requirements of the *National Fuel Gas Code*, *ANSI Z223.1/NFPA 54* as it relates to the installation of gas fired water heaters. The service agency must also have a thorough understanding of this Installation and Operating manual, and be able to perform repairs strictly in accordance with the service guidelines provided by the manufacturer.

Gas Supplier: The Natural Gas or Propane Utility or service who supplies gas for utilization by the gas burning appliances within this application. The gas supplier typically has responsibility for the inspection and code approval of gas piping up to and including the Natural Gas meter or Propane storage tank of a building. Many gas suppliers also offer service and inspection of appliances within the building.

INTRODUCTION

PREPARING FOR INSTALLATION

1. Read the entire manual before attempting to install or operate the water heater. Pay close attention to the General Safety section of this manual. If you don't follow the safety rules, the water heater may not operate safely. It could cause property damage, injury and/or death.
2. This manual contains instructions for the installation, operation, and maintenance of the water heater. It also contains warnings throughout the manual that you must read and be aware of. All warnings and all instructions are essential to the proper operation of the water heater and your safety. Detailed installation diagrams are also found in this manual. These diagrams will serve to provide the installer with a reference. It is essential that all venting, water piping, gas piping and wiring be installed as shown.
3. Particular attention should be given to the installation of thermometers as these are necessary for checking the operation of the water heater.
4. The principal components of the water heater are identified in *Features and Components* (page 13). Use this reference to locate and identify various components on the water heater.
5. See maintenance schedule in *Maintenance* (page 50) and *Troubleshooting* (page 54). By using the troubleshooting checklist the user may be able to make minor operational adjustments and avoid unnecessary service calls. However, service and diagnostic procedures should only be performed by a Qualified Service Agency.
Note: Costs to correct installation errors are not covered under the limited warranty.
6. Be sure to turn off power when working on or near the electrical system of the water heater. Never touch electrical components with wet hands or when standing in water.
7. The installation must conform with these instructions and local code authority having jurisdiction. In absence of local codes, installation must comply with current editions of the *National Fuel Gas Code, ANSI Z223.1/NFPA 54 and the National Electrical Code*, *NFPA 70*. All documents are available from:
CSA International
8501 East Pleasant Valley Road
Cleveland, Ohio, United States
44131-5575

NFPA documents are also available from:
National Fire Protection Association
1 Batterymarch Park
Quincy, MA 02269.
8. The water heater, when installed, must be electrically grounded in accordance with the local codes or in the absence of local codes: current edition of the *National Electrical Code, NFPA 70*.
9. If after reading this manual you have any questions or do not understand any portion of the instructions, call the toll free number on the front page of this manual for technical assistance. In order to expedite your request, please have the full Model, Serial and Series number of the water heater you are working with available for the technician. This information is located on the water heater's rating plate.
10. Carefully plan the placement of the water heater. Examine the location to ensure that it complies with the requirements in *Before you Begin* (page 16).

MASSACHUSETTS INSTALLATION REQUIREMENTS

For all side wall terminated, horizontally vented power vent, direct vent, and power direct vent gas fueled water heaters installed in every dwelling, building or structure used in whole or in part for residential purposes, including those owned or operated by the Commonwealth and where the side wall exhaust vent termination is less than seven (7) feet above finished grade in the area of the venting, including but not limited to decks and porches, the following requirements should be satisfied:

INSTALLATION OF CARBON MONOXIDE DETECTORS At the time of installation of the side wall horizontal vented gas fueled equipment, the installing plumber or gasfitter should observe that a hard wired carbon monoxide detector with an alarm and battery back-up is installed on the floor level where the gas equipment is to be installed. In addition, the installing plumber or gasfitter should observe that a battery operated or hard wired carbon monoxide detector with an alarm is installed on each additional level of the dwelling, building or structure served by the sidewall horizontal vented gas fueled equipment. It should be the responsibility of the property owner to secure the services of qualified licensed professionals for the installation of hard wired carbon monoxide detectors.

In the event that the side wall horizontally vented gas fueled equipment is installed in a crawl space or an attic, the hard wired carbon monoxide detector with alarm and battery back-up may be installed on the next adjacent floor level.

In the event that the requirements of this subdivision can not be met at the time of completion of installation, the owner should have a period of thirty (30) days to comply with

the above requirements provided that during said thirty (30) day period, a battery operated carbon monoxide detector with an alarm should be installed.

APPROVED CARBON MONOXIDE DETECTORS Each carbon monoxide detector as required in accordance with the above provisions should comply with NFPA 720 and be ANSI/UL 2034 listed and CSA certified.

SIGNAGE A metal or plastic identification plate should be permanently mounted to the exterior of the building at a minimum height of eight (8) feet above grade directly in line with the exhaust vent terminal for the horizontally vented gas fueled heating appliance or equipment. The sign should read, in print size no less than one-half (1/2) inch in size, **GAS VENT DIRECTLY BELOW. KEEP CLEAR OF ALL OBSTRUCTIONS.**

INSPECTION The state or local gas inspector of the side wall horizontally vented gas fueled equipment should not approve the installation unless, upon inspection, the inspector observes carbon monoxide detectors and signage installed in accordance with the provisions of 248 CMR 5.08(2)(a) 1 through 4.

EXEMPTIONS: The following equipment is exempt from 248 CMR 5.08(2)(a)1 through 4:

1. The equipment listed in Chapter 10 entitled Equipment Not Required To Be Vented in the most current edition of NFPA 54 as adopted by the Board; and
2. Product Approved side wall horizontally vented gas fueled equipment installed in a room or structure separate from the dwelling, building, or structure used in whole or in part for residential purposes.

MANUFACTURER REQUIREMENTS - GAS EQUIPMENT VENTING SYSTEM PROVIDED

When the manufacturer of Product Approved side wall horizontally vented gas equipment provides a venting system design or venting system components with the equipment, the instructions provided by the manufacturer for installation of the equipment and the venting system should include:

1. Detailed instructions for the installation of the venting system design or the venting system components; and
2. A complete parts list for the venting system design or venting system.

MANUFACTURER REQUIREMENTS - GAS EQUIPMENT VENTING SYSTEM NOT PROVIDED

When the manufacturer of a Product Approved side wall horizontally vented gas fueled equipment does not provide the parts for venting the flue gases, but identifies special venting systems, the following requirements should be satisfied by the manufacturer:

1. The referenced special venting system instructions should be included with the appliance or equipment installation instructions; and
2. The special venting systems should be Product Approved by the Board, and the instructions for that system should include a parts list and detailed installation instructions.

A copy of all installation instructions for all Product Approved side wall horizontally vented gas fueled equipment, all venting instructions, all parts lists for venting instructions, and/or all venting design instructions should remain with the appliance or equipment at the completion of the installation.

FEATURES AND COMPONENTS

- | | | |
|---|--|---|
| 1. Termination Elbow With Vent Screen
(Included in Vent Kit) | 16. *Metal Drain Pan | 30. Temperature Sensor |
| 2. *Vent Pipe | 17. *Ground Joint Union (Gas Connection) | 31. Burner Insulation Shield |
| 3. *Vent Pipe Elbow (Long Radius) | 18. *Sediment Trap | 32. Burner Refractory |
| 4. *Inlet Water Shut-Off Valve | 19. *Main Manual Gas Shut-Off Valve | 33. Burner |
| 5. *Thermal Expansion Tank | 20. *Gas Supply* | 34. Burner Gasket |
| 6. *Union (Dielectric Water Connection) | 21. Intake Air Pressure Switch (IAPS) | 35. Flange Gasket |
| 7. Cold-Water Inlet Nipple/Diptube | 22. Hot-Water Outlet Nipple/Anode | 36. Ignition Gasket |
| 8. T&P Valve | 23. Anode (Under Cap) | 37. Flame Sensor |
| 9. Discharge Pipe | 24. **Combo Heating System Supply Outlet
(Optional) | 38. Hot Surface Igniter |
| 10. Control Cover (Plastic) | 25. Control Panel | 39. Air Intake Venturi |
| 11. Condensate Drain (1/2" MNPT) | 26. Outlet Air Pressure Switch (OAPS) | 40. Blower Gasket |
| 12. Condensate Trap/Exhaust Tee
(Included in Vent Kit) | 27. Blower | 41. Blower/Burner Flange |
| 13. Drain Valve | 28. Gas Control Valve | 42. Air Intake Adapter (Rubber) |
| 14. *Floor Drain | 29. **Combo Heating System Return Inlet
(Optional) | 43. Air Intake Terminal (Included in Vent Kit) |
| 15. Leak Detection Module (Optional) | | 44. 2" Dia x 3.00" Long Air Intake Pipe
(included in Vent Kit) |
| | | 45. *Vacuum Relief Valve [†] |
| | | 46. Air Intake Check Valve (LP Models Only) |

* Items not supplied with the water heater.

** The side recirculation loop connections may not be used as the primary water inlet and outlet connections. See *Combo Heating* (page 38).

Venting as shown for PDV (Power Direct Vent) applications.

[†]Install vacuum relief valve per local codes.

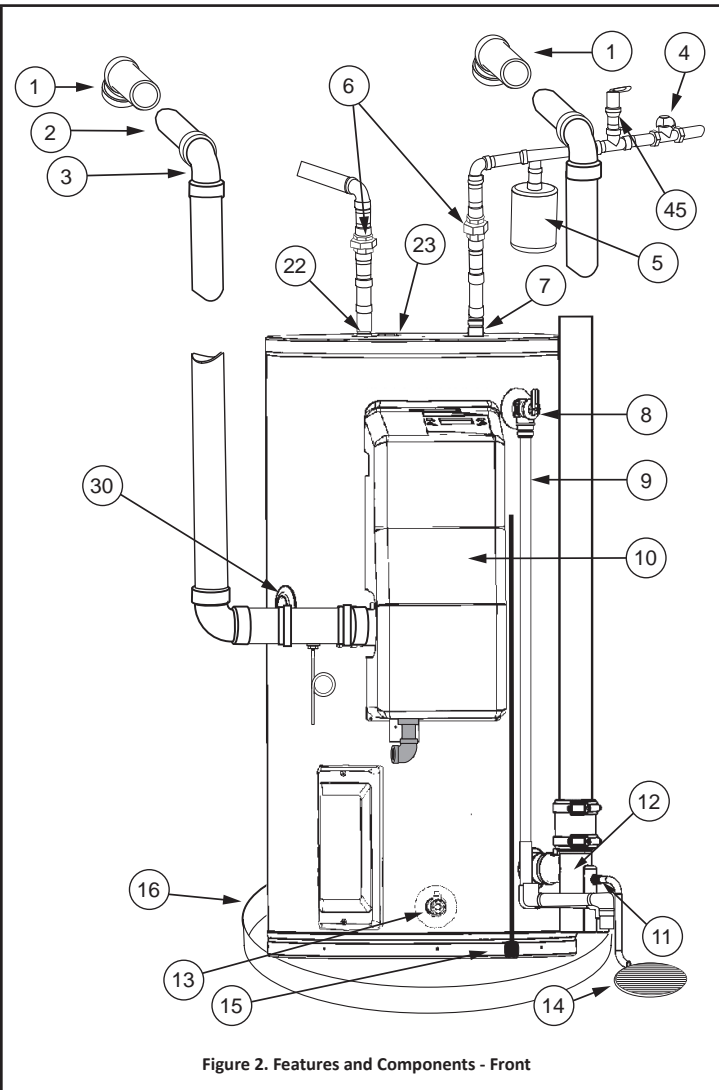

Figure 2. Features and Components - Front

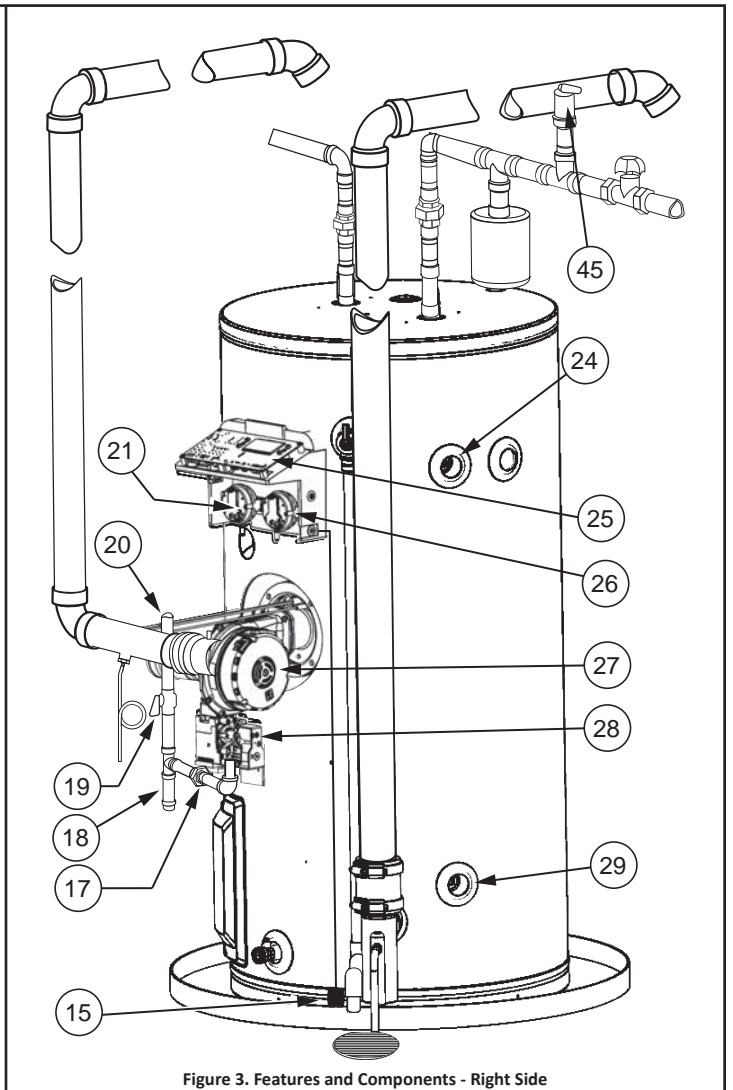

Figure 3. Features and Components - Right Side

FEATURES AND COMPONENTS

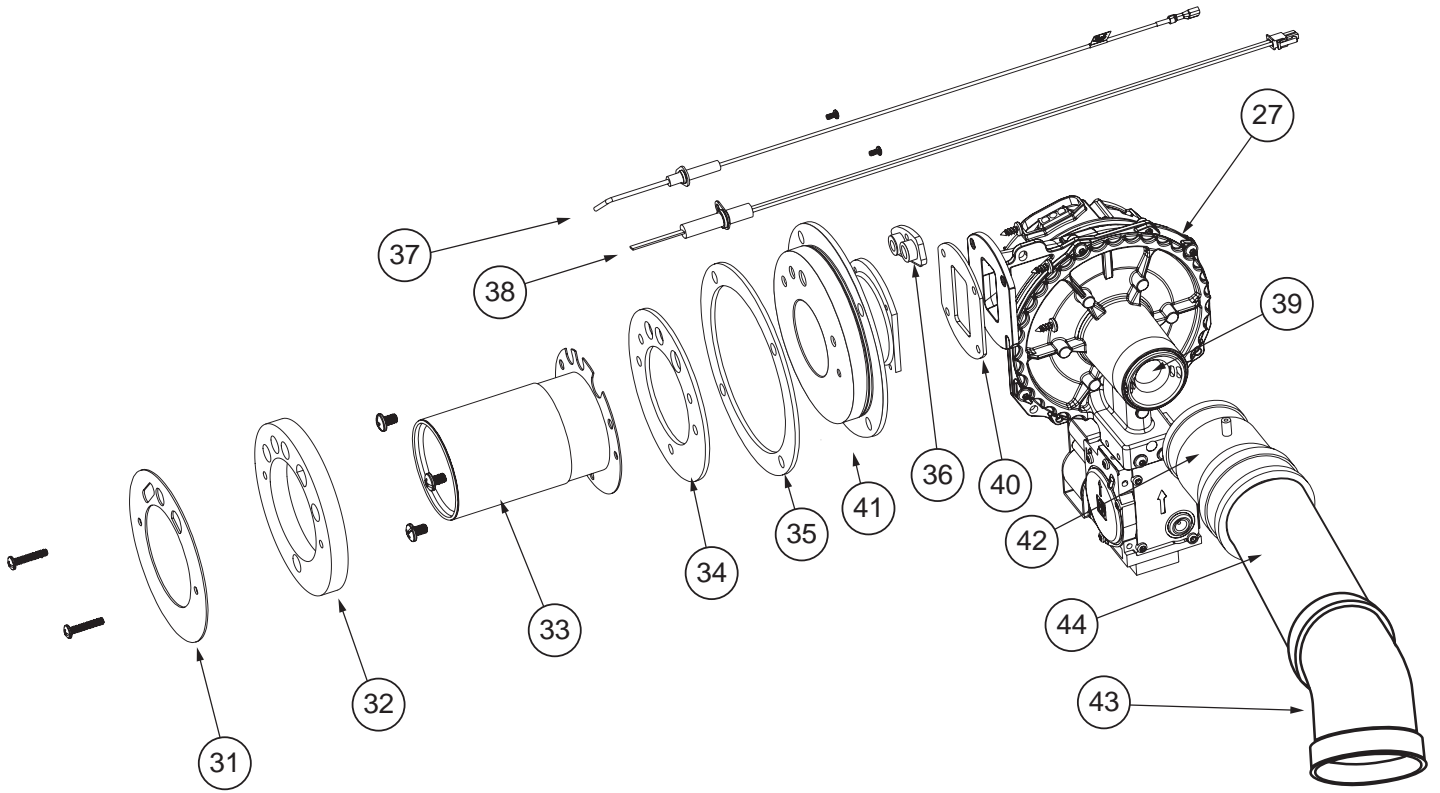

Figure 4. Blower and Intake Air Components for Natural Gas

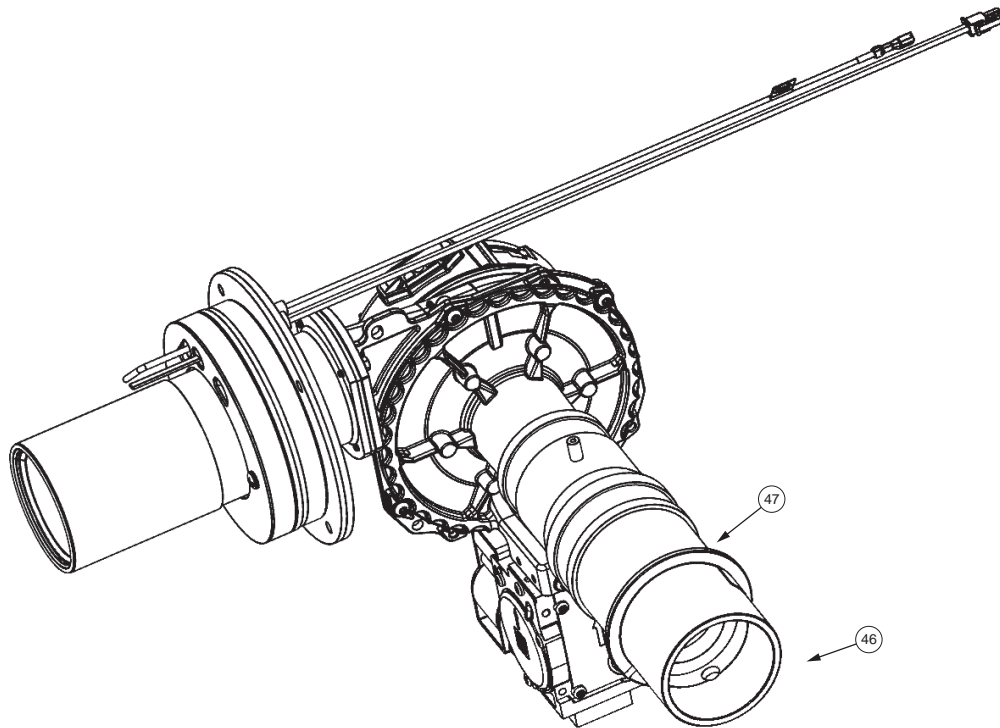

Figure 5. Blower and Intake Air Components for LP Gas

FEATURES AND COMPONENTS





MODEL CHARACTERISTICS

*Manifold Pressure		Minimum Supply Pressure	Maximum Supply Pressure	Electrical Characteristics	
Gas Type	In. W.C. (kPA)	In. W.C.(kPA)	In W.C.(kPA)	Volts/Hz	Amperes
Natural	0" (0)	3.5(1.10)	14(3.49)	120/60	<5
Propane	0"(0)	8.0 (1.99)	14 (3.49)	120/60	<5

* The manifold pressure is the factory setting and is not adjustable. A negative pressure will be seen with just the blower running without the Gas Control Valve open.

CONTROLS AND SWITCHES

Control Module

This heater includes a control module with a user interface and a LCD display (see *Figure 6*). There are three primary functions of the control: turn the appliance on/off, set/control water temperature, setting operating mode. To turn heater on: hold the  (ON/OFF) button depressed for 5 seconds. To change desired setpoint temperature use the  (Plus) or  (Minus) buttons, then lock in setpoint by depressing  (Lock/Unlock). For more information on this control module. See *Control System Operation* (page 49).

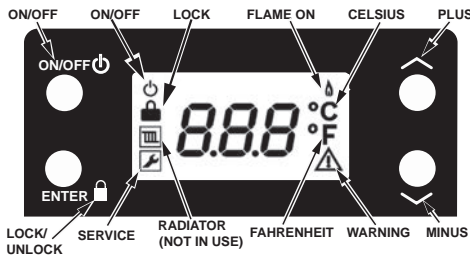

Figure 6. User Interface Screen

Pressure Switches

This model is provided with two pressure switches. These switches are essential to the

safe and proper operation of the unit. Each switch provides feedback to the control to ensure the control will detect which switch has been activated and indicate the appropriate error code (blocked vent outlet or blocked air intake).

Outlet Air Pressure Switch (OAPS)

The Outlet Air Pressure Switch is set up to shut the unit off when a build-up of positive pressure in the exhaust vent pipe occurs. This switch is a positive pressure switch that requires an increase in pressure to change the electrical contacts from normally closed to open. When this switch prevents the unit from igniting, most likely the exhaust is blocked by some means. Check to see if the condensate is allowed to flow freely from the condensate trap and for obstructions in the exhaust venting and exhaust vent terminal. Also verify that the vent length does not exceed the maximum allowed as shown in *Combustion Air and Ventilation* (page 21).

Intake Air Pressure Switch (IAPS)

The Intake Air Pressure Switch is set up to shut the unit off when a build-up of negative pressure in the intake air pipe occurs. This switch is a negative pressure switch that

requires an increase in negative pressure to change the electrical contacts from normally closed to open. The switch is connected to the pressure tap on the rubber blower adapter connected to the inlet of the blower. When this switch prevents the unit from igniting, most likely the intake is blocked. Verify that the intake air pipe, and the intake air termination are free of obstructions that may prevent air from entering the unit. Also verify the intake air pipe length does not exceed the maximum allowed in *Combustion Air and Ventilation* (page 21).

Hot Surface Igniter (HSI)

This heater is provided with a Hot Surface Igniter. It can automatically ignite the burner when a "call for heat" is received. On a "call for heat" the Hot Surface Igniter will heat up for 12 seconds and will ignite the gas/air mixture when the gas valve opens. The ignitor then turns off.

Flame Sensor

This heater includes a flame sensor to detect the flame current and continue to monitor the flame current during the burner operation to ensure the burner operates only in a safe condition.

GETTING STARTED

BEFORE YOU BEGIN



Figure 7. Flexible connectors use compression fittings and do not require soldering.



Figure 8. Use a non-contact circuit tester to insure that the power is off before you work on a circuit.



Figure 9. Install a Pressure Reducing Valve set to 50 to 60 PSI.

1. Review all of the instructions before you begin work. Improper installation can damage the

storage booster tank, your home and other property, and can present risks of serious injury or death.

2. This water heater is designed as a Category I, non-direct vented water heater which takes its combustion air either from the installation area or from air ducted to the unit from the outside. This water heater must be installed according to all local and state/provincial codes.
3. Check with your local and state authorities for any local or state codes that apply to your area. In the absence of local and state codes, follow National Fire Protection Association (NFPA-70) and the current editions of the National Electric Code (NEC) and the International Plumbing Code (IPC). The instructions in this manual comply with national codes, but the installer is responsible for complying with local codes.

Note: If you lack the necessary skills required to properly install this water heater, or you have difficulty following the instructions, you should not proceed but have a qualified person perform the installation of this water heater.

4. Before you start, be sure you have the following tools and supplies:
 - Common plumbing tools (depending on what type of water pipes you have).

- Thread sealant tape or pipe joint compound approved for potable water.
- For homes with copper pipes, you may purchase a Gas Water Heater Hook-Up Kit (available at your local plumbing supplier) with compression fittings that don't require soldering. This kit includes two 12" flex water lines, two compression fittings, an 18" flexible gas line, two nipples, and thread sealant tape.
- For homes with plastic pipe, use threaded connectors suitable for the specific type of plastic pipe used: CPVC or PEX (cross-linked polyethylene). Do not use PVC pipe.
- A chloride-free liquid solution is the only approved fuel gas or combustion product leak verification method.
- An appliance dolly or hand truck to move the water heater.

RECOMMENDED ACCESSORIES:

- A metal drain pan.
- Automatic water leak detection and shut-off device.
- Pressure Reducing Valve.
- Thermal Expansion Tank.
- Thermostatic Mixing Valves at each point-of-use.
- Fuel gas and carbon monoxide detector.

GETTING STARTED

ROUGH-IN DIMENSIONS

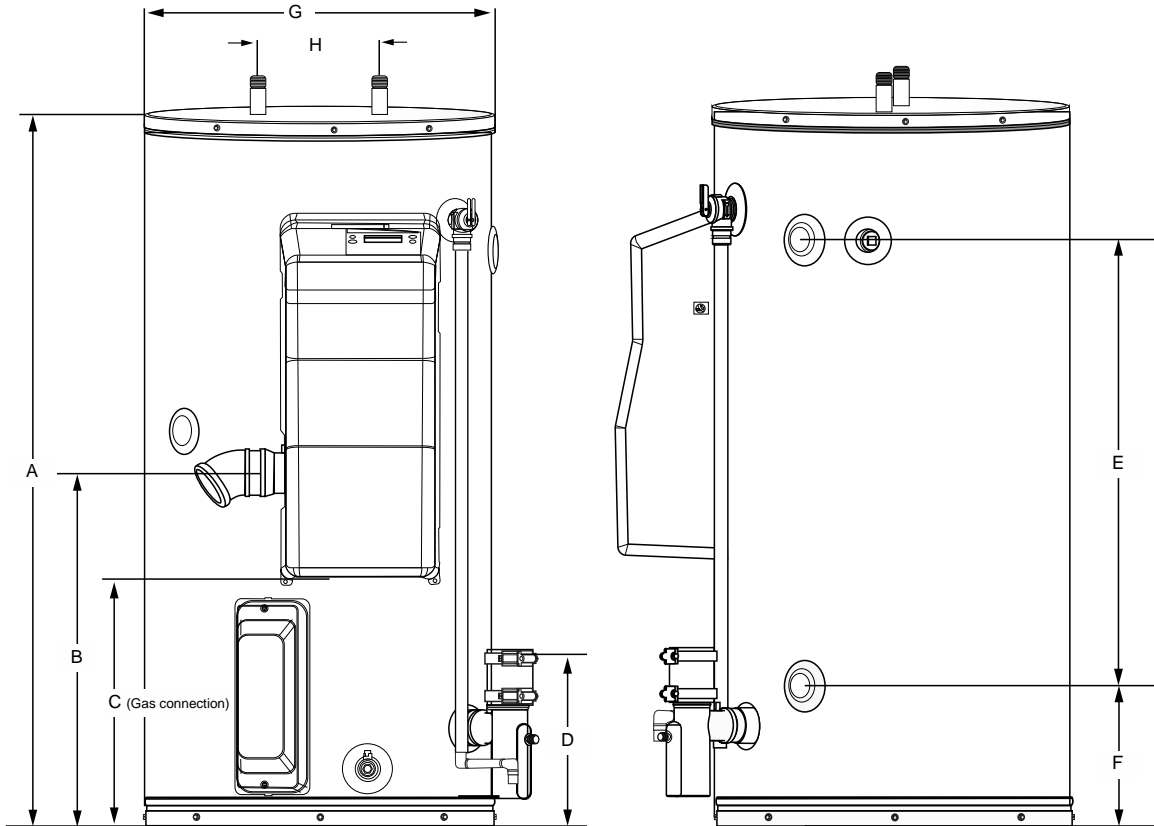

Figure 10. Rough-In Front- and Right-Side Views

Table 3. Rough-In Dimensions Key in Inches (centimeters)								
Models	A	B	C	D	E	F	G	H
40 Gallon	45.00 (114.3)	22.38 (56.84)	15.75 (40)	10.5 (26.67)	27.75 (70.49)	8.75 (22.22)	22.00 (55.88)	8.00 (20.32)
50 Gallon	54.50 (138)	24.75 (62.86)	18.75 (47.62)	9.75 (24.76)	37.75 (95.89)	8.00 (20.32)	22.00 (55.88)	8.00 (20.32)

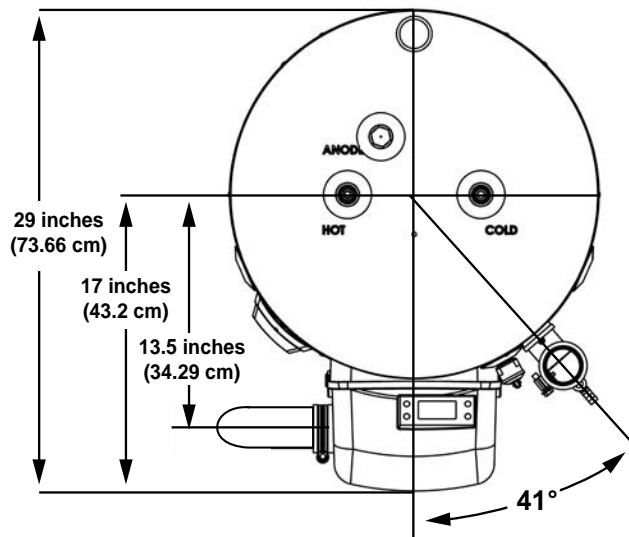

Figure 11. Rough-In Top View

GETTING STARTED

VERIFY THAT YOUR HOME IS EQUIPPED AND UP-TO-DATE FOR PROPER OPERATION

Installing a new water heater is the perfect time to examine your home's plumbing system and make sure the system is up to current code standards. There have likely been plumbing code changes since the old water heater was installed. We recommend installing the following accessories and any other needed changes to bring your home up to the latest code requirements. Updating your plumbing system can help extend the life of your water heater, avoid damage to your home and property, and reduce the risk of serious injuries or death. Inspect your home and install any devices you need to comply with current codes and assure that your new water heater performs at its best. Check with your local plumbing official for more information.

Water Pressure

Most codes allow a maximum incoming water pressure of 80 psi (we recommend a working pressure no higher than 50-60 psi). Check your home's water pressure gauge and adjust if necessary. High water pressure can damage the water heater, piping, and other appliances.

HOW: Purchase an inexpensive water pressure gauge from your local plumbing supplier. Connect the water pressure gauge to an outside faucet and measure the maximum water pressure experienced throughout a 24-hour period (highest water pressures often occur at night).



Figure 12. Use a Water Pressure Gauge to make sure your home's water pressure is not too high.

To adjust your home's water pressure: Locate your home's Pressure Reducing Valve (PRV) on the main incoming (cold) water supply line and adjust the water pressure control to between 50 and 60 psi. If your home does not have a Pressure Reducing Valve, install a PRV on the home's main water supply line and set it to between 50 and 60 psi. Pressure Reducing Valves are available at your local plumbing supplier.

BACKGROUND: Over the years, many utilities have increased water supply pressures so they can serve more homes. In some homes today, pressures can exceed 100 psi. High water pressures can damage water heaters, causing premature leaks. If you have replaced toilet valves, had a water leak, or had to repair appliances connected to the plumbing system, pay particular attention to your home's water pressure. When purchasing a PRV, make sure the PRV has a built-in bypass.

Water Pressure Increase Caused by Thermal Expansion

Verify that you have a properly sized Thermal Expansion Tank. We recommend installing an expansion tank if your home does not have one. Plumbing codes require a properly pressurized, properly sized Thermal Expansion Tank in almost all homes.



Figure 13. A Thermal Expansion Tank helps protect the home's plumbing system from pressure spikes.

HOW: Connect the Thermal Expansion Tank (available at your local plumbing supplier) to the cold water supply line near the water heater. The expansion tank contains a bladder and an air charge. To work properly, the Thermal Expansion Tank must be sized according to the water heater's tank capacity and pressurized to match the home's incoming water pressure. Refer to the instructions provided with the Thermal Expansion Tank for installation details.

BACKGROUND: Water expands when heated, and the increased volume of water must have a place to go, or thermal expansion will cause large increases in water pressure (despite the use of a Pressure Reducing Valve in the home's main water supply line). The Safe Drinking Water Act of 1974 requires the use of back-flow preventers and check valves to restrict water from your home reentering the public water system. Back-flow preventers are often installed in water meters and may not be readily visible.

As a result, most all plumbing systems today are now "closed," and almost all homes now need a Thermal Expansion Tank.

A Thermal Expansion Tank is a practical and inexpensive way to help avoid damage to the water heater, washing machine, dishwasher, ice maker, and even toilet valves. If your toilet occasionally runs for no apparent reason (usually briefly at night), that may be due to thermal expansion increasing the water pressure temporarily.

Water Pipe and Tank Leaks

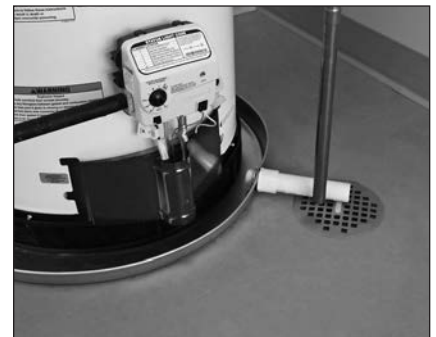

Figure 14. A metal drain pan piped to an adequate drain can help protect flooring from leaks and drips.

Leaks from plumbing pipes or from the water heater itself can damage property and could cause a fire risk.

- Install an automatic leak detection and shut-off device (available at your local plumbing supplier). These devices can detect water leaks and can shut off the water heater's water supply if a leak occurs. Install a metal drain pan (available at your local plumbing supplier) under the water heater to catch condensation or leaks from the piping connections or tank. Most codes require, and we recommend, installing the water heater in a metal drain pan that is piped to an adequate drain. The drain pan must be at least two inches wider than the diameter of the water heater. Install the drain pan so the water level would be limited to a maximum depth of 1- $\frac{3}{4}$ ". The pan must not restrict air flow to the burner.

WATER TEMPERATURE REGULATION

Install Thermostatic Mixing Valves to regulate the temperature of the water supplied to each point-of-use (for example, kitchen sink, bathroom sink, bath, shower). Install and adjust the mixing valve according to its manufacturer's instructions..

GETTING STARTED

⚠️ WARNING

Burn Hazard



The temperature of the water in a water heater can exceed the thermostat setting to the point of being able to cause burns.

Even if the water heater's thermostat is set to a relatively low temperature, hot water can scald. Install Thermostatic Mixing Valves at each point-of-use to reduce the risk of scalding.

See Table 1 (page 6).



Figure 15. Thermostatic Mixing Valves installed at each point-of-use can help avoid scalding.

BACKGROUND: A Thermostatic Mixing Valve, installed at each point-of-use, mixes hot water from the water heater with cold water to more precisely regulate the temperature of hot water supplied to fixtures. If you are not sure if your plumbing system is equipped with properly installed and adjusted Thermostatic Mixing Valves at each point where hot water is used, contact a qualified person.

VERIFY THAT THE LOCATION IS APPROPRIATE

⚠️ WARNING

Fire and Explosion Hazard



Flammable vapors can leak from their containers and be ignited by the water heater. The resulting fire and/or explosion can cause serious injury or death.

Do the following to avoid this hazard:

- Do not place chemical vapor emitting products near air intake and exhaust terminations.
- Do not use or store flammable vapor products, such as gasoline, solvents, or adhesives in the same room or area near the water heater or other appliances.

⚠️ CAUTION

Property Damage Hazard



Over time, the tank and fittings of the water heater can begin to leak and cause water damage.

Locate the water heater in an area where water leakage from the heater or connections will not result in damage to the area or the lower floors of the structure.

Carefully choose a location for the new water heater. The placement is a very important consideration for the safety of the occupants in the building and for the most economical use of the water heater.

Whether replacing an existing water heater or installing the water heater in a new location observe the following critical points:

1. The water heater must be located indoors.
2. The water heater must not be located in an area where it will be subject to freezing temperatures.
3. Locate the water heater so it is protected and not subject to physical damage by a moving vehicle. In garage installation avoid damage to your water heater by installing a vehicle stop as shown in Figure 16. Check state and local codes for requirements prior to installation.
6. Locate the water heater close to the point of major hot water usage.
7. Locate the water heater close to a 120 Vac power supply. See *Electrical Supply* (page 39) for requirements.
8. Locate the water heater where an adequate supply of fresh air for combustion and ventilation can be obtained. See *Combustion Air and Ventilation* (page 21).
9. Locate the water heater where the vent and intake air piping, when installed, will remain within the maximum equivalent lengths allowed. See *Combustion Air and Ventilation* (page 21).
10. Do not locate the water heater where noise (such as the Combustion Blower) during normal operation will be objectionable in adjacent areas.
11. Do not locate the water heater where the subsequent installation of the vent (exhaust) or intake air terminations would be objectionable due to noise at the termination(s). This includes locations close to or across from windows and doors. See *Power Direct Venting (PDV)* (page 25) and *Power Vent (PV)* (page 31).

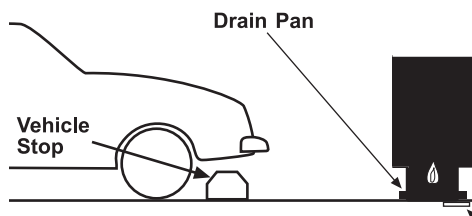

Figure 16. Garage Installation

4. Locate the water heater on a level surface.
5. Locate the water heater near a floor drain. The water heater should be located in an area where leakage of the tank or connections will not result in damage to the area adjacent to the water heater or to lower floors of the structure. When such locations cannot be avoided, it is recommended that a metal drain pan, piped to adequate drain, be installed under the water heater. Drain pan should be fabricated with sides at least 45 mm (1-3/4") deep with diameter at least 50 mm (2")

⚠️ WARNING

Fire and Explosion Hazard



Under certain circumstances, the water heater can explode and catch fire, resulting in property damage, personal injury, or death.



Do the following to avoid these conditions:

- Do not store or use gasoline or other flammable vapors and liquids in the vicinity of this or any other appliance.
- Avoid all ignition sources if you smell gas.
- Do not expose water heater controls to excessive gas pressure.
- Use only the gas shown on the water heater rating label.
- Maintain required clearances to combustibles.
- Keep ignition sources away from faucets after extended periods of non-use.
- Install sediment trap in accordance with *NFPA54* or *CSA-B1491*.
- Read the instruction manual before installing, using, or servicing the water heater.
- Contact a qualified installer or service agency for installation and service.

GETTING STARTED

Do not locate water heater areas where flammable liquids (vapors) are likely to be present or stored (garages, storage and utility areas, etc.): Flammable liquids (such as gasoline, solvents, propane (LP or butane, etc.)) and other substances (such as adhesives, open paint cans etc.) emit flammable vapors which can be ignited by a gas water heater's ignition device or main burner. The resulting flashback and fire can cause death or serious burns to anyone in the area.

⚠ WARNING

⚠ Vapors from flammable liquids may explode and catch fire causing death or severe burns.

Do not use or store flammable products such as gasoline, solvents or adhesives in the same room or area near the water heater.

Keep flammable products:

1. far away from heater,
2. in approved containers,
3. tightly closed and
4. out of children's reach.

Water heater has a main burner and hot surface igniter. The hot surface igniter:

1. can be triggered at any time and
2. the hot surface will ignite flammable vapors.

Vapors:

1. cannot be seen,
2. are heavier than air,
3. go a long way on the floor and
4. can be carried from other rooms to the electrodes by air currents.

Installation: Do not install the water heater where flammable products will be stored or used.

When the water heater is installed directly on carpeting, the water heater shall be installed on a metal or wood panel extending beyond the full width and depth of the water heater by at least 3" in any direction or, if the water heater is installed in an alcove or closet, the entire floor shall be covered by the panel. The panel must be strong enough to carry the weight of the heater when full of water.

⚠ WARNING

Fire Hazard



Installing the water heater too close to combustible materials can result in a fire resulting in property damage, serious injury, or death.

Maintain minimum required clearances to combustibles.

Minimum clearances from combustible materials are stated on the data plate located on the front of the water heater. Standard clearances are 0" at the sides and rear, 0" from the front, and 0" from the top. If the clearances from combustible material stated on the water heater differ from the standard clearances, install the water heater according to the clearances stated on the water heater.

Adequate clearance for inspection and service should be considered before installation. A minimum of 24" of front clearance and 4" on each side should be provided for access to replaceable and/or serviceable parts such as drain valve, condensate drain, temperature-pressure relief valve, and the vent connection (exhaust tee).

Figure 17 may be used as a reference guide to locate the specific clearance locations. When installing the water heater, consideration must be given to proper location. The location selected should be as close to the wall as practicable and as centralized with the water piping system as possible.

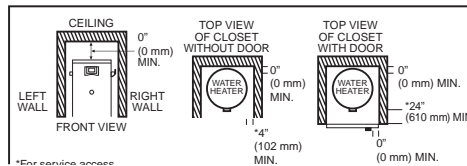



Figure 17. Clearance Locations

REMOVING THE OLD WATER HEATER

1. Read each installation step and decide if you have the necessary skills to install the water heater. Only proceed if you are comfortable you can safely perform the work. If you are not sure, have a qualified person perform the installation.
2. Follow the directions in the manual that came with your old water heater for shutting it down.
3. If the old water heater is a gas water heater, turn the manual gas valve for the water heater's gas supply line to OFF.
4. Open a hot water faucet and let the hot water run until it is cool.

⚠ WARNING

Burn Hazard



Be sure the water runs cool before draining the tank to reduce the risk of scalding.

5. Connect a garden hose to the drain valve and place the other end of the hose in a drain, outside, or in buckets (sediment in the bottom of the tank may clog the valve and prevent it from draining. If you cannot get the tank to drain, contact a qualified person).
6. Turn the cold water supply valve OFF.

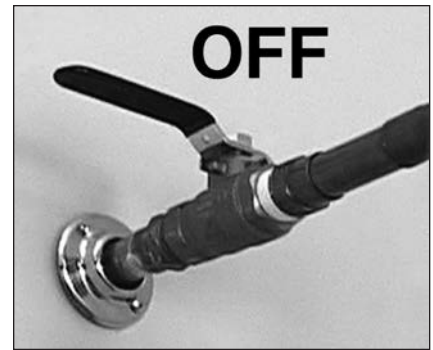

Figure 18. Cold water supply in OFF position.

7. Open the drain valve on the water heater.



Figure 19. Draining the old water heater.

8. Also open a hot water faucet to help the water in the tank drain faster.
9. When the tank is empty, disconnect the Temperature & Pressure (T&P) Relief Valve discharge pipe. You may be able to reuse the discharge pipe, but do not reuse the old T&P Relief Valve. A new T&P Relief Valve comes with your new water heater.



Figure 20. Removing the T&P Relief Valve discharge pipe.

10. If the old water heater is a gas water heater and has either a draft hood or vent piping, ensure that the components are cool and then disconnect them according to the manual that came with the water heater. You may need to support the vent piping until the new water heater is in place.
11. If the water heater has input air ducting, disconnect the water heater at the input air connection fitting.

GETTING STARTED

- Disconnect the water pipes. In many cases, the water pipes are connected by a threaded union, which can be disconnected with wrenches. If you must cut the water pipes, cut the pipes close to the water heater's inlet and outlet connections, leaving the water pipes as long as possible. If necessary, you can make them shorter later when you install the new water heater.
- If the water heater is a gas water heater, confirm that the manual gas valve for the water heater's supply line is turned OFF. Disconnect the gas line from the water heater's gas control valve and cap it.
- Remove the old water heater. Use an appliance dolly or hand truck to move the water heater.

⚠ WARNING

Lift Hazard

This water heater is too heavy to be carried safely by one person. Attempting to do so could cause serious injury.

Avoid this hazard by doing the following:

- Use at least two people to lift the water heater.
- Be sure you both have a good grip before lifting.
- Use an appliance dolly or hand truck to move the water heater.

COMBUSTION AIR AND VENTILATION

A gas water heater cannot operate properly without the correct amount of air for combustion. Never obstruct the flow of ventilation air. If you have any doubts or questions at all, call your gas supplier. Failure to provide the proper amount of combustion air can result in a fire or explosion and cause death, serious bodily injury, or property damage.

⚠ WARNING

Breathing Hazard-Carbon Monoxide Gas

An improperly installed water heater can emit carbon monoxide. Breathing carbon monoxide can cause brain damage or death.

Do the following to avoid carbon monoxide poisoning:

- Install the water heater in accordance with the instruction manual and NFPA 54.
- To avoid injury, combustion and ventilation air must be taken from outdoors.
- Do not place chemical vapor emitting products near water heater.

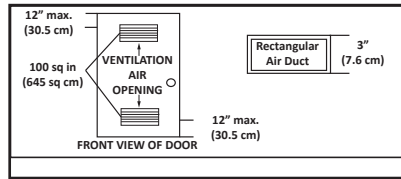

Figure 21. Closet Door Ventilation

Propellants of aerosol sprays and volatile compounds, (cleaners, chlorine based chemicals, refrigerants, etc.) in addition to being highly flammable in many cases, will also react to form corrosive acids when exposed to the combustion products of the water heater. The results can be hazardous, and also cause product failure. Air for combustion and ventilation must not come from a corrosive atmosphere. Any failure due to corrosive elements in the atmosphere is excluded from warranty coverage.

It is imperative that the water heater(s) be installed direct vent so that all air for combustion and ventilation is taken from outdoors.

CORROSION AND WATER QUALITY

Water quality will vary from location to location and may contain contaminants that can reduce the life or performance of the water heater.

Contaminates which can reduce the life or performance of the water heater, if present in high quantities, include those which contribute to hardness (dissolved minerals such as sodium, calcium and magnesium); plus chlorides and sulfates. Additionally, water that is too acidic or alkaline (measured as pH) can reduce the life of the water heater. Water treatment systems (such as water softeners for hardness) should be used and maintained properly if the contaminate levels exceed the following:

Warranty is void in applications which exceed the water quality requirements listed below.

Table 4. Water Quality Requirements	
Total Hardness	12 grains per gal. max.
Chloride	12 grains per gal. max.
pH	6.5-8.0
Alkalinity	12 grains per gal. max.

INSTALL SHUT-OFF AND THERMOSTATIC MIXING VALVES

- If one is not already installed, install a manual shut-off valve in the cold water

line that supplies the water heater. Install the shut-off valve near the water heater so that it is readily accessible. Only use a full-flow ball or gate valve compatible with potable water.

- Install a Thermostatic Mixing Valve at each point-of-use (for example, kitchen sink, bathroom sink, bath, shower) per the valve manufacturer's instructions.



Figure 22. Install Thermostatic Mixing Valves at each point where hot water will be used.

⚠ WARNING

Burn Hazard

The temperature of the water in a water heater can exceed the thermostat setting to the point of being able to cause burns.

Even if the water heater's thermostat is set to a relatively low temperature, hot water can scald. Install Thermostatic Mixing Valves at each point-of-use to reduce the risk of scalding.

- For water heaters that are fed by a solar water heating system (or any other pre-heating system), always install a Thermostatic Mixing Valve or other temperature limiting device in the inlet water supply line to limit water supply inlet temperature to 120°F. Solar water heating systems can supply water with temperatures exceeding 180°F and may result in water heater malfunction.

⚠ WARNING

Burn Hazard

Hot water provided by solar heating systems can cause severe burns instantly, resulting in serious injury or death.

INSTALLING THE VENT SYSTEM

PLANNING THE VENT SYSTEM

This water heater may be installed in either a Power Direct Vent (PDV) or in a Power Vent (PV) configuration. Both configurations must be properly vented for removal of exhaust gases to the outside atmosphere. Correct installation of the vent pipe system is mandatory for the safe and efficient operation of this water heater and is an important factor in the life of the unit.

This water heater, when installed in a PDV configuration, has a direct vent system in which all combustion products (exhaust) must be vented to the outdoors and will require outdoor air for combustion. Both intake and exhaust piping will require a sealed piping system as described in these instructions.

When installed in a Power Vent (PV) configuration, this water heater will require room air for combustion. Adequate air intake resources are required. The exhaust piping will require a sealed piping system as described in these instructions.

⚠ CAUTION

Property Damage Hazard



Improper installation use and service could result in property damage.

This unit must be configured with both an air intake terminal and an exhaust terminal.

⚠ WARNING

Breathing Hazard-Carbon Monoxide Gas



Certain abnormal conditions can cause the water heater to emit carbon monoxide. Breathing carbon monoxide can cause brain damage or death.

Do the following to prevent these abnormal conditions:

- Do not operate water heater if any part has been exposed to flooding or water damage.
- Do not operate if soot buildup is present.
- Do not obstruct water heater air intake with insulating jacket.
- Do not place chemical vapor emitting products near water heater.
- Never operate the heater unless it is vented to the outdoors and has adequate air supply to avoid risks of improper operation, fire, explosion, or asphyxiation.
- Always read and understand the instruction manual.
- Install gas and carbon monoxide detectors in the vicinity of the water heater.

Important: This water heater must be vented separately from all other appliances. **DO NOT** common vent this water heater with any other appliance. **DO NOT** vent into a common chimney.

Table 5 (page 23) lists the allowable vent materials. Figure 36, Figure 37, and Figure 38 (page 29) show various end termination details and clearances for PDV installations. Figure 42, Figure 43, and Figure 44 (page 33) shows various end termination details and clearances for PV installations

Note: The information provided in Figure 3 is intended as a guideline for good vent installation practices only.

This water heater may be vented horizontally through a wall or vertically through the roof. Pipe runs must be adequately supported along both vertical and horizontal runs according to local codes or the venting manufacturer's instructions such as IPEX (www.ipexna.com/resources/technical-library).

Note: Do not use an elbow as a support point. Elbows are not designed to carry the load or stresses of the venting system if they are rigidly held.

Note: Do not use the condensation trap as a support point. It not designed to carry the load or stresses of the venting system. Vent piping must be supported adequately and not put any weight on the condensation trap.

Vent pipe must be installed in accordance with all local codes or, in the absence of such, the latest edition of *National Fuel Gas Code, ANSI Z223.1/NFPA 54*. In addition, clearances from combustible materials must be provided in accordance with information in the "Locating The New Water Heater" section of this manual. Take note of the clearance and venting requirements when installing in a confined space such as a small room or closet. Vent pipes serving power vented appliances are classified by building codes as "vent connectors".

- Plan the vent system layout so that proper clearances are maintained from plumbing and wiring.
- Plan the layout of the vent system from the vent termination to the water heater considering all the elbows (90° and 45°) plus the number of feet of pipe that will be needed to install the total vent system.
- Venting should be as direct as possible with the fewest number of fittings.

- Use long radius 45° and long radius 90° elbows wherever possible.
- Avoid using 90° elbows "back to back" and do not use street elbows.
- Maintain a minimum 6" straight section between elbows. Closely coupled and short radius elbows reduce the venting capacity. Figure 24 (page 23) shows examples of vent pipe connections.

⚠ WARNING

Breathing Hazard-Carbon Monoxide Gas



An improperly installed water heater can emit carbon monoxide. Breathing carbon monoxide can cause brain damage or death.

Do the following to avoid carbon monoxide poisoning:

- Install the water heater in accordance with the instruction manual and NFPA 54.
- To avoid injury, combustion and ventilation air must be taken from outdoors.
- Do not place chemical vapor emitting products near water heater.

VENT KIT

A Vent Kit included with this water heater may be used for standard sidewall or roof termination. It consists of:

1. One 45° ULC PVC elbow for installation on exhaust venting,
2. One 45° ULC PVC elbow for installation on air intake venting,
3. Wire mesh screens for installation on the intake and outlet terminations to prevent objects from blocking the venting system. See *Vent Screens* (page 24).
4. 2" Dia x 3.00" L PVC Pipe for connection to blower intake in PV (Power Vent) installations.
5. 2" rubber coupling for connections to condensate/exhaust tee.
6. Condensate/Exhaust tee.
7. Outlet pressure switch soft tubing for connection to Condensate/Exhaust tee.

Debris screens are to be installed at the terminations to keep foreign materials out of the venting.

INSTALLING THE VENT SYSTEM

Note: The Condensate/Exhaust tee and outlet pressure switch tubing will need to be connected to the water heater before the exhaust venting can be connected to the water heater. See *Installing the Exhaust/Condensate Tee* (page 24).

Additional vent termination options (not included) are available. Instruction for installing these other termination methods are described later in this section.

Important: After completing the venting installation, ensure the vent pipe is not blocked or restricted in any way.

VENT PIPE MATERIAL

This heater is certified to be installed using Schedule 40 vent material. Check local codes to determine which materials are allowed in your area and only use approved material. All venting material and components must be joined with the approved primer/cleaner and solvent cement. Do not cement the venting system to the heater. For polypropylene vent systems follow manufacturer's instructions.

Note: Polypropylene vent systems require separate adaptor, termination, and elbows (field supplied).

Material	Pipe and Fitting Nomenclature	Applicable Standard
PVC	DWV	ASTM D2665 or CSA B181.2
PVC	Sch 40, 80, 120	ASTM D1785 or CSA B137.3
PVC	SDR series	ASTM D2241 or CSA B137.3
PVC	BH	ULC S636‡ UL 1738§
CPVC	CPVC 41	ASTM D2846 or CSA B137.6
CPVC	Sch 40, 80	ASTM F441 or CSA B137.6
CPVC	SDR series	ASTM-F442
CPVC	BH	ULC S636‡ UL 1738§
ABS	Sch 40 DWV	ASTM D2661§, CSA B181.1§ or ULC S636‡
Polypropylene	n/a	ULC S636‡ UL 1738§

‡ Applicable to Canada only.
§ Applicable to the United States only.
Use of cellular core PVC (ASTM F891), cellular core CPVC, or Radel®(polyphenylsulfone) in non-metallic venting systems is prohibited.

Important: Use only solid (not foam core) piping. Plastic pipe and fittings are available through most plumbing suppliers. Always check the marking on the pipe to make sure you are using the correct material. Use of cellular core PVC (ASTM F891), cellular core CPVC, or Radel® (polyphenylsulfone) in non-metallic venting systems is prohibited.

VENT PIPE LENGTH AND SIZING

See *Table 11* (page 30), and *Table 14* (page 34) for vent pipe sizing. If the installation requires a vent riser, suitable drainage must be provided to ensure condensation does not accumulate. See *Figure 45* (page 34). The specified maximum lengths are for **each** of the intake and exhaust systems and **not** for the combined lengths of both systems. Minimum pipe length is 2' with a minimum of one 90° elbow per side (intake and exhaust).

1. Determine termination type and pipe size.
2. Determine number of elbows in vent system. Do not include termination elbow. Calculate the maximum equivalent length of the exhaust and air intake system using *Table 6* to determine equivalent length values.



Figure 23. Vent Pipe Elbows

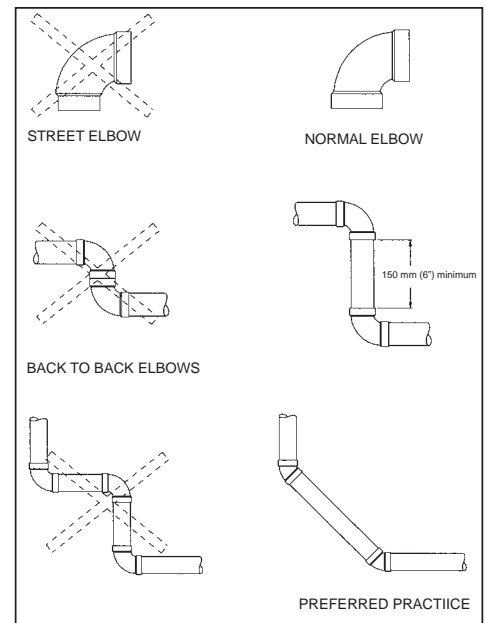

Figure 24. Vent Pipe Elbow Use

Elbow Type	Equivalent Length Of Straight Pipe	
	Short Sweep/ Radius	Long Sweep/ Radius
90°	8'	5'
45°	4'	2.5'

POLYPROPYLENE VENT SYSTEMS

Note: This heater is certified to use solid wall polypropylene venting. Do not install with the corrugated type flex venting.

Polypropylene vent systems do not use cement to connect the pipe and elbow sections but use a push together gasket seal method. Do not attempt to connect polypropylene with sealant cement.

- Polypropylene vent systems are designed to use specific adaptors to connect the water heater venting. These adaptors are available through your venting supplier.
- The PVC vent termination elbow supplied with this heater has been certified to be used with polypropylene vent systems. A polypropylene to PVC end connection is required and is available through your venting supplier.
- Optional wall plates that fit the polypropylene venting are also available through your supplier.

INSTALLING THE VENT SYSTEM

Pressure Switch Setting (NC)	Nat Gas	LP Gas
Outlet Air (OAPS)	1.8" w.c.	1.43" w.c.
Intake Air (IAPS)	-1.88" w.c.	-1.62" w.c.

Vent Pipe Runs

1. The exhaust vent system must not, under any circumstances, be run downhill then run uphill thus forming a valley. It may leave a space to accumulate condensation and block vent pipe.
2. Horizontal runs require a minimum 1/8" rise per 5' and a support according to venting manufacturer's instructions. Ensure there is enough height between heater and termination to raise vent pipe runs the required distance.
3. Vertical runs must provide proper support to prevent stress on the pipes according to venting manufacturer's instructions.

VENT PIPE INSTALLATION

The following guidelines should be followed when installing the air intake and exhaust vent system:

- Vent diameter must not be reduced unless specifically noted in the installation instructions.
- Support all horizontal pipe runs according to local codes or the venting manufacturer's instructions such as IPEX (www.ipexna.com/resources/technical-library).
- Covering non-metallic vent piping with thermal insulation is prohibited.
- Vents run through unconditioned spaces where below freezing temperatures are expected, are not recommended.
- Vents run through unconditioned spaces inside a building may result in the condensation of flue gases during the winter season.

Venting Instructions

1. Calculate "Equivalent Vent Length" before starting. Do not exceed the values shown in *Table 11* (page 30), and *Table 14* (page 34).
2. Follow the vent manufacturer's instructions for installing the venting.
3. Install the properly sized debris screen into the outlet elbow and secure with a small quantity of silicone sealant.

4. Do not seal the vent piping to the wall until the venting is properly connected to the condensate trap assembly.
5. Complete the venting installation by sealing around the termination assembly where it passes through the outside wall, inside and out, with silicone or other suitable sealant. Apply enough sealant to secure the (optional) cover plate to the wall.

CAUTION

Property Damage Hazard

Solvent cements and primers for plastic pipe are flammable liquids and emit flammable vapors. Improper use can cause an explosion and fire that would result in property damage.

- Use only in well ventilated areas.
- Do not use near any open flame and all ignition sources, including water heaters.
- Use only the solvent cement and primer appropriate for the venting material being used.

VENT SCREENS

Installed in the intake and vent termination elbows, the debris vent screen is required to keep foreign objects, rodents and small birds from entering the venting system. Any such debris can activate the Blocked Air sensors and prevent the water heater from operating.

- Install the debris vent screen in both the air intake pipe and the exhaust pipe.
- Gently push the screen into the termination elbow until it sits against the inside shoulder.
- The debris vent screens are self-securing.

Note: In the concentric vent application, the vent screen is to be installed in the exhaust piping only.

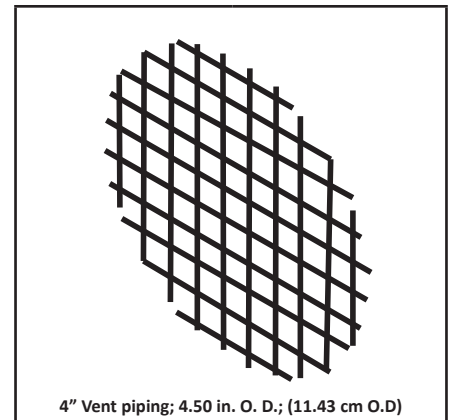
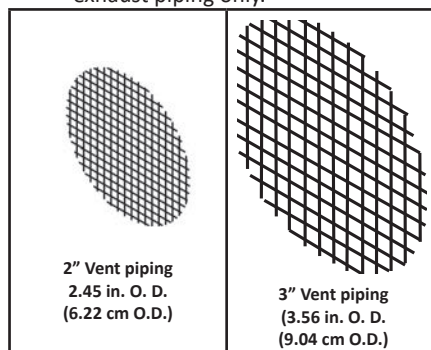

4" Vent piping; 4.50 in. O. D.; (11.43 cm O.D)

Figure 25. Termination Debris Screen

WARNING

Breathing Hazard-Carbon Monoxide Gas

Installing the vent screen improperly or installing the wrong screen can cause the water heater to emit carbon monoxide. Breathing carbon monoxide can cause brain damage or death.

Install the appropriate screen designed for this water heater according to the manual and all applicable codes.

INSTALLING THE EXHAUST/CONDENSATE TEE

Before the exhaust vent system can be installed the factory supplied Exhaust/Condensate Tee must be installed on the water heater. See Vent Kit for parts. See *Figure 26*.

1. Remove the Exhaust/Condensate Tee and soft tubing from the vent kit.
2. Attach the Exhaust/Condensate Tee to the heaters exhaust rubber coupling located at bottom right of water heater. Note orientation.
3. Tighten the hose clamp to 24-30 in/Lbs.
4. Attach one end of the soft tubing to the hose barb located on the Exhaust/ Condensate Tee.
5. Attach the other end of the soft tubing to the aluminum tubing attached to the water heater. This aluminum tubing is connected to the Outlet Air Pressure Switch, located on the control panel.

Note: The Exhaust/Condensate Tee must be connected to the Outlet Air Pressure

INSTALLING THE VENT SYSTEM

Switch or the OAPS will not function properly.



Figure 26. Condensate/Exhaust Tee Installation

IMPORTANT NOTES AND WARNINGS

- Do not allow insulation to cover the vent piping.
- During operation the plastic piping will expand as it heats up and contract as it cools down. This is normal for this type of venting. Rigidly fastening the vent piping can cause undue stress that may result in the cracking or fracturing the vent piping material. A fracture of the venting pipe may pose a serious safety hazard. To prevent stressing of the vent system, all hangers and supports must allow the vent piping freedom to move.
- All power vented water heaters generate a certain amount of operational noise. In order to minimize noise transmission to the support structure, use isolation pads between the pipe hangers and the vent pipe.

POWER DIRECT VENTING (PDV)

The combustion air intake and exhaust vent system and termination may be installed in one of the following type terminations:

1. Horizontal (2 Pipe) (air intake and exhaust vent).
2. Vertical (2 Pipe) (air intake and exhaust vent)
3. Concentric (horizontal/side wall installation).
4. Concentric (vertical/roof installation).
5. Low Profile (2 Pipe) (air intake and exhaust vent). Horizontal use only.

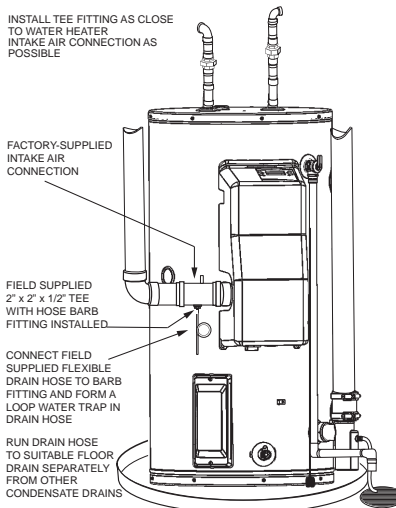

Figure 27. Intake Air Condensate Tee Installation

DIRECT VENT AIR INTAKE MOISTURE PROTECTION

The air intake piping in a direct vent system will normally not have any moisture accumulation in it. However, in certain cases, moisture may build up and needs to be drained. Typical situations include, but are not limited to:

- Cold outdoor temperature, particularly if the air inlet is short
- Heater being used mostly for space heating
- Air inlet pipe has vertical rise near the heater

Installations with any of these conditions are required to provide a moisture drain with a trap that flows to a waste drain. See *Figure 27*.

A horizontal section of the air inlet pipe, near the heater should include a 2" x 2" x 1/2" tee and a hose barb fitting to drain the water. The tee should be as close to the heater as is practical. The drain tubing in any installation should have a loop trap and flow to an appropriate waste drain. The air intake drain line must be entirely separate from the exhaust vent outlet condensate line.

INSTALLING THE VENT SYSTEM

TERMINATION CLEARANCES SIDEWALL POWER VENT

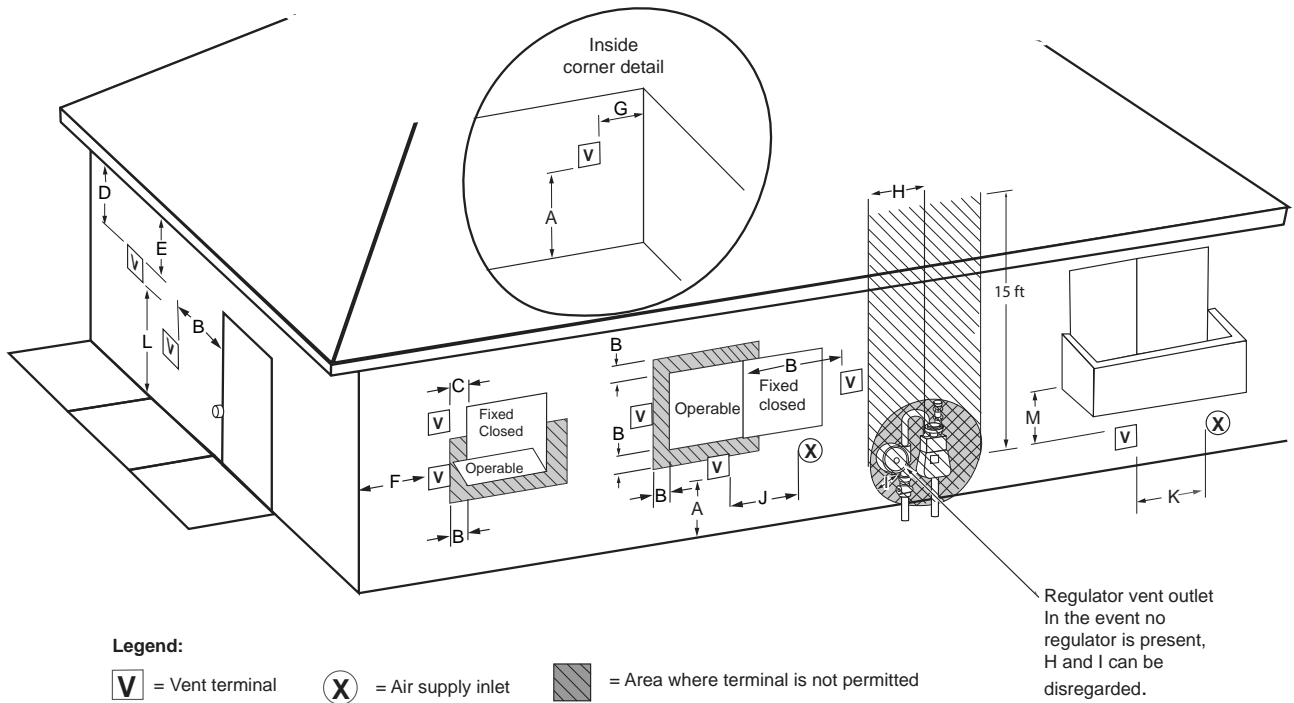

Figure 28. Sidewall Power Direct Vent Using Outside Air

Table 8. Termination Clearances for Sidewall Power Vent			
	Type of Clearance	Canadian Installations 1	US Installations 2
A	Clearance above grade, veranda, porch, deck or balcony	12 inches (30 cm)	12 inches (30 cm)
B	Clearance to window or door that may be opened	<ul style="list-style-type: none"> 6 in (15 cm) for appliances ≤ 10,000 Btuh (3 kW) 12 in (30 cm) for appliances > 10,000 Btuh (3 kW) and ≤ 100,000 Btuh (30 kW) 36 in (91 cm) for appliances > 100,000 Btuh (30 kW) 	<ul style="list-style-type: none"> 6 in (15 cm) for appliances ≤ 10,000 Btuh (3 kW) 9 in (23 cm) for appliances > 10,000 Btuh (3 kW) and ≤ 50,000 Btuh (15 kW) 12 in (30 cm) for appliances > 50,000 Btuh (15 kW)
C	Clearance to permanently closed window	12 inches (30 cm)*	12 inches (30 cm)*
D	Vertical clearance to ventilated soffit located above the terminal within a horizontal distance of 2 feet (61 cm) from the center line of the terminal	12 inches (30 cm)*	12 inches (30 cm)*
E	Clearance to unventilated soffit	12 inches (30 cm)*	12 inches (30 cm)*
F	Clearance to outside corner	2 feet (60 cm)*	2 feet (60 cm)*
G	Clearance to inside corner	18 inches (45 cm)*	18 inches (45 cm)*

Table 8. Termination Clearances for Sidewall Power Vent			
	Type of Clearance	Canadian Installations 1	US Installations 2
H	Clearance to each side of center line extended above meter/regulator assembly	3 ft (91 cm) within a height of 15 ft (4.6 m)	Clearance in accordance with local installation codes and the requirements of the gas supplier
I	Clearance to service regulator vent outlet	3 ft (91 cm)	Clearance in accordance with local installation codes and the requirements of the gas supplier
J	Clearance to a non-mechanical air supply inlet into building or combustion air inlet to any other appliance	<ul style="list-style-type: none"> 6 in (15 cm) for appliances ≤ 10,000 Btuh (3 kW) 12 in (30 cm) for appliances > 10,000 Btuh (3 kW) and ≤ 100,000 Btuh (30 kW) 36 in (91 cm) for appliances > 100,000 Btuh (30 kW) 	<ul style="list-style-type: none"> 6 in (15 cm) for appliances ≤ 10,000 Btuh (3 kW) 9 in (23 cm) for appliances > 10,000 Btuh (3 kW) and ≤ 50,000 Btuh (15 kW) 12 in (30 cm) for appliances > 50,000 Btuh (15 kW)
K	Clearance to a mechanical air supply inlet	6 feet (1.83 m)	3 feet (91 cm) above if within 10 feet (3 m) horizontally
L	Clearance above paved sidewalk or paved driveway located on public property	7 feet (2.13 m)†	7 ft (2.13 m) for mechanical draft systems (Category I appliances); vents for Category II and IV appliances cannot be located above public walkways or other areas where condensate or vapor can cause a nuisance or hazard
M	Clearance under veranda, porch, deck, or balcony	12 inches (30 cm) ‡	12 inches (30 cm) ‡

1. In accordance with the current *CSA B149.1, Natural Gas and Propane Installation Code*.

2. In accordance with the current *ANSI Z223.1/NFPA 54, National Fuel Gas Code*.

† A vent shall not terminate directly above a sidewalk or paved driveway that is located between two single family dwellings and serves both dwellings where it can cause hazardous frost or ice accumulations on adjacent property surfaces.

‡ Permitted only if veranda, porch, deck, or balcony is fully open on a minimum of two sides beneath the floor.

* Clearance in accordance with local installation codes and the requirements of the gas supplier and the manufacturer's installation instructions

INSTALLING THE VENT SYSTEM

SIDE WALL VENT TERMINATION (STANDARD)

Important: When terminating the vent on a side wall, the following specifications pertaining to terminal location must be followed. See *Figure 29*.

1. The air intake terminal and the exhaust vent terminal must terminate on the same exterior wall.
2. The vertical center-line of the air intake terminal must be located at a minimum of 8" from the vertical center-line of the exhaust vent terminal.
3. The horizontal center-line of the air intake terminal may not be located more than 24" below the horizontal center-line of the exhaust vent terminal.
4. To avoid exhaust recirculation, the air intake terminal may be rotated away from the exhaust vent terminal. See *Figure 29*.

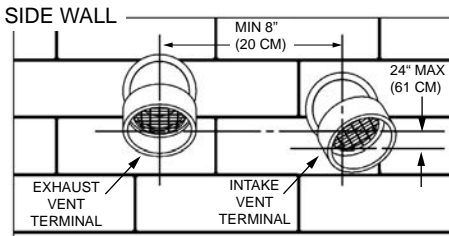

Figure 29. Sidewall Vent Clearances*

Roof Vent Termination (Standard)

Important: When terminating the vents through a roof, the following specifications pertaining to terminal location must be followed. See *Figure 30*.

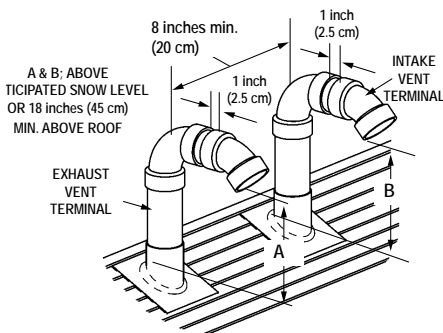

Figure 30. Roof Vent Snow Clearances

1. The air intake termination and the exhaust vent termination shall extend 12" above anticipated snow level and at least 12" above the roof.
2. Must provide proper support for all pipes protruding through roof.
3. The vertical roof terminations should be sealed with a plumbing roof boot or equivalent flashing.
4. The air intake termination and the exhaust vent termination must penetrate the same side of roof.
5. The center-line of the air intake termination and the center-line of the exhaust vent termination must not be closer than 8".
6. The air intake terminal and the exhaust vent terminal must be oriented facing downward and the same direction.

SIDE WALL VENT FOR COLD CLIMATES

Some winter weather conditions present a risk of ice accumulation at the intake termination screen. Such accumulation will restrict intake air flow. If local conditions present this risk, the termination configuration shown in *Figure 31* is recommended. This will reduce the possibility of exhaust gas recirculation as well as reduce the chance of ice accumulation.

If necessary to avoid snow accumulation, the intake vent terminal may be fitted with a riser similar to that on the exhaust vent terminal. Both the intake and exhaust vent terminations may be 90° elbows if specified by local requirements.

Note: The vertical center-line of the air intake termination and the vertical center-line of the exhaust vent termination must not be closer than 8".

Important: Elbows (excluding the termination elbow) and risers must be considered when calculating total equivalent

vent length. See *Table 6* (page 23).

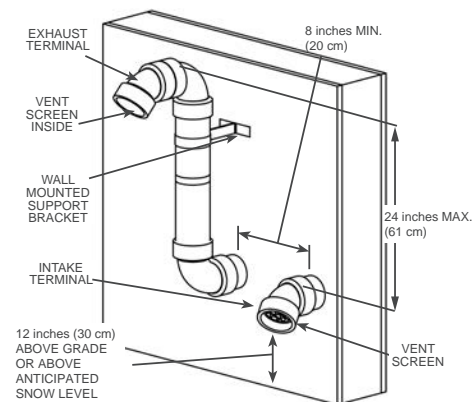

Figure 31. Sidewall Vent Termination Snow Clearances

Debris screens may be removed while there is a risk of ice accumulation but this can make the air intake susceptible to debris buildup, the entry of birds, other small animals or rodents. If the debris screens are removed to prevent ice accumulation, it is recommended that they be re-installed when the risk of ice accumulation has passed.

CONCENTRIC VENT TERMINATION

A concentric vent termination kit (see *Table 9*) may be used for vertical or horizontal terminations. *Figure 33* illustrates the concentric vent kit for a horizontal (side wall) installation. To prevent rain water from entering the exhaust outlet, slope the vent kit at a downward pitch of 1/4" per 5' away from the inside wall. Ensure the combustion air intake location is above the anticipated snow level. *Figure 32* illustrates the concentric vent termination kit in a vertical (roof) installation. Ensure the combustion air intake location is above the anticipated snow level.

Vent Dia.	P/N
2"	100153586
3"	100111100

INSTALLING THE VENT SYSTEM

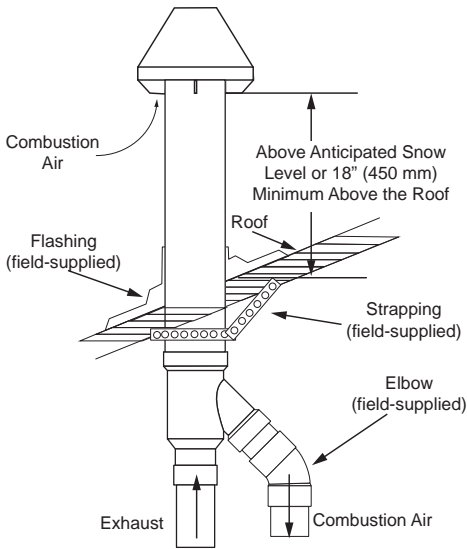

Figure 32. Concentric Termination (Vertical)

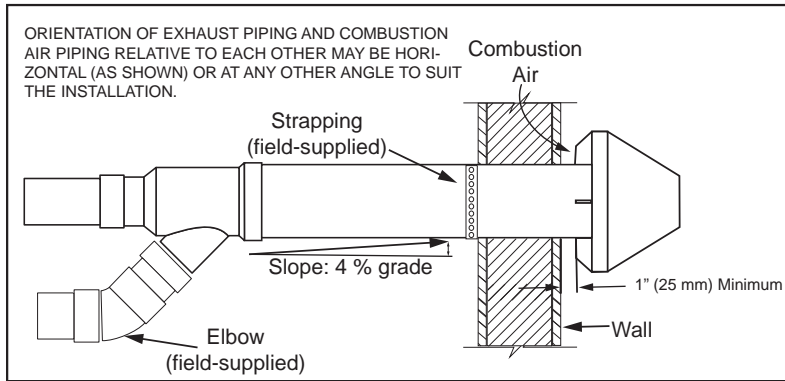

Figure 33. Concentric Termination (Horizontal)

MULTIPLE CONCENTRIC VENT TERMINATION

When two concentric vent kits are being installed, the vent hood centers shall be **either** less than 9.5" apart **or** more than 43.5" apart.

Spacings between 9.5" and 43.5" are not allowed due to the possibility of exhaust cross circulation (see Figure 34).

When more than 2 kits are installed only 2 of them shall be less than 9.5" apart. Never install 3 termination kits together less than 9.5" apart (see Figure 35).

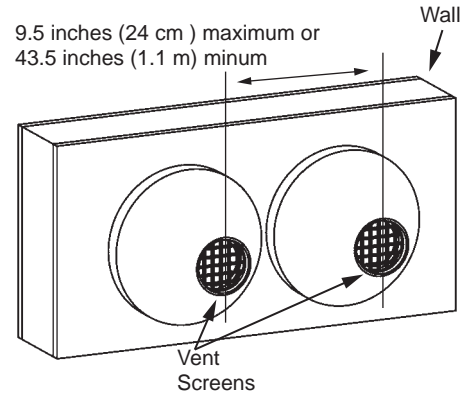

Figure 34. Through-Wall Multi-Concentric Vent Termination

Note: If a termination elbow is required by local codes, install vent screen in elbow instead of the concentric vent exhaust.

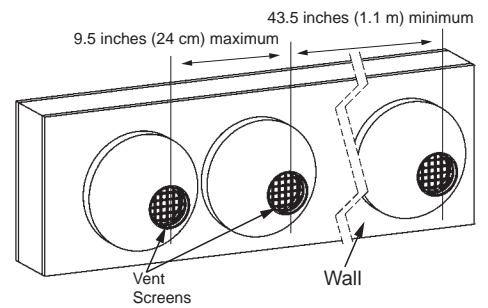

Figure 35. Three or More Sidewall Concentric Vent Terminations

Note: If a termination elbow is required by local codes, install vent screen in elbow instead of the concentric vent exhaust.

INSTALLING THE VENT SYSTEM

LOW PROFILE VENT INSTALLATION

This water heater is certified for sidewall direct venting with IPEX System 636 Low Profile Vent Kit. Follow instructions below for proper installations.

All termination kits must be located and installed in accordance with local building code and *CSA B149.1 Natural Gas and Propane Installation Code*.

1. Once the proper location has been determined, cut 2 holes in the wall large enough to accommodate the pipe. Pipe diameters and distance between hole centers can be found in *Table 10* (page 29).
2. Slide both the intake and exhaust pipes through the holes. Solvent cement both pipes to the base of the vent termination kit, follow the solvent cementing procedures outlined in the *IPEX System 636 Installation Guide*, which is available on the web www.ipexinc.com.
3. To fasten the Base to the wall, use the supplied screws and anchors. A 3/16" (5 mm) hole, 1-3/16" (30 mm) deep, will need to be drilled for the anchors. Locate the anchor hole using the base as a template.
4. Screw the Cap to the Base using the supplied screws.
5. Once the vent termination and pipes are secured, the wall penetrations will need to be sealed from the interior using a PVC-compatible sealant material.
6. All vent pipes and air inlets must terminate at the same height to avoid possibility of severe personal injury, death, or substantial property damage.
7. Operate heater through 1 heat cycle to ensure combustion-air and vent pipes are

properly connected to concentric vent termination

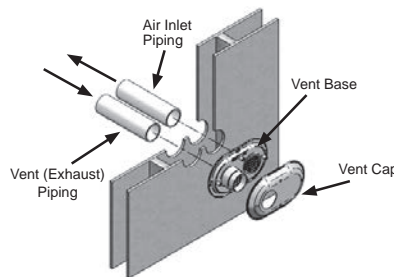

Figure 36. Inlet and Vent Flow in Low Profile Installation

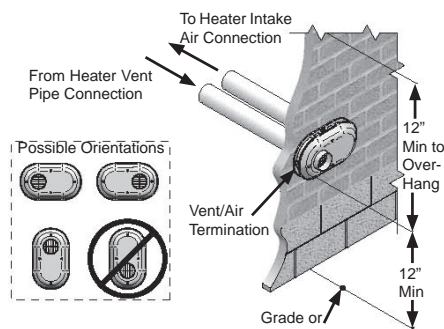

Figure 37. Low Profile Sidewall Clearances

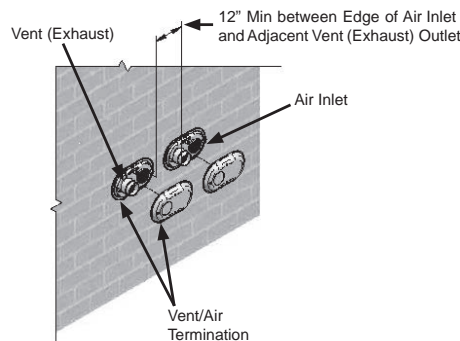

Figure 38. Multiple Low Profile Vent Clearances

Table 10. Low Profile Termination Kits - Dimensions

AOS Kit Number	IPEX Part Number	Description	Pipe Outside Diameter	Hole Spacing (Center to Center)
100086241	196984	2" Flush Mount Vent Kitt	2.375"	5.63"
100187887	196985	3" Flush Mount Vent Kit	3.5"	7.63"
Each Kit Contains				
Qty	Item Description			
1	Base (two holes)			
1	Cap (one hole)			
8	Stainless Steel Screws			
4	Plastic Anchors			

INSTALLING THE VENT SYSTEM

CALCULATING EQUIVALENT FEET (PDV)

Table 11. Calculating Equivalent Feet (PDV)

Water Heater Model	Heater Input (Btu/Hr)	Vent Size (Inside Diam.)	Pressure Switch Settings (in. w.c.)		2 Pipe Equiv. Vent Length		Conc. Vent Equiv. Vent Length	
			Intake (Nat/LP)	Exhaust (Nat/LP)	Max.	Min.	Max.	Min.
			40 gal.	50,000	2"	-1.88/-1.62	1.8/1.43	60 ft. (18.3 m) + termination
50 gal.	65,000	-1.88/-1.62	1.8/1.43					
40 gal.	50,000	3"	-1.88/-1.62	1.8/1.43	150 ft. (45.7 m) + termination	10 ft. (3.0 m) + termination	150 ft. (45.7 m) + termination	10 ft. (3.0 m) + termination
50 gal.	65,000		-1.88/-1.62	1.8/1.43				
40 gal.	50,000	4"	-1.88/-1.62	1.8/1.43	180 ft. (54.8 m) + termination	15 ft. (4.6 m) + termination	N/A	N/A
50 gal.	65,000		-1.88/-1.62	1.8/1.43				

Notes:

1. A horizontal vent must have a 45° or 90° vent termination elbow to direct the vent pipe downward unless otherwise specified by local requirements.
2. A vertical vent must have a 90° elbow to direct the vent pipe horizontally followed by a vent termination 45° elbow to direct the vent pipe downward unless otherwise specified by local requirements.
3. If additional elbows are used in the vent system the allowable vent lengths are reduced.
4. Two 45° elbows are considered the equivalent of one 90° elbow.

Table 12. Calculating Low Profile Equivalent Vent Length

Water Heater Model	Heater Input (Btu/Hr)	Vent Size (Inside Diam.)	Pressure Switch Settings (in. w.c.)		Low Profile Equiv. Vent Length	
			Intake (Nat/LP)	Exhaust (Nat/LP)	Max.	Min.
			40 gal.	50,000	2"	-1.88/-1.62
50 gal.	65,000	-1.88/-1.62	1.8/1.43			
40 gal.	50,000	3"	-1.88/-1.62	1.8/1.43	150 ft. (45.7 m) + termination	10 ft. (3.0 m) + termination
50 gal.	65,000		-1.88/-1.62	1.8/1.43		

Notes:

1. If additional elbows are used in the vent system the allowable vent lengths are reduced.
2. Two 45° elbows are considered the equivalent of one 90° elbow.

INSTALLING THE VENT SYSTEM

TERMINATION CLEARANCES OTHER THAN SIDEWALL DIRECT VENT

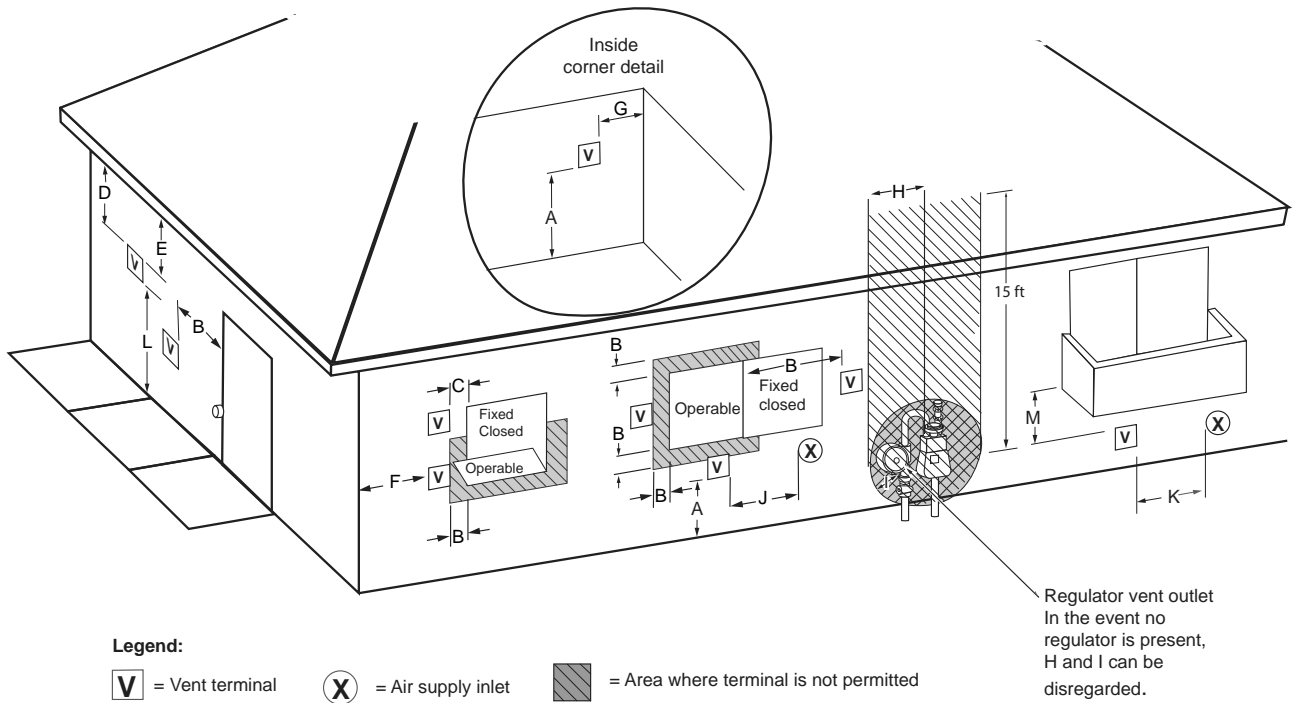

Figure 41. Other than Direct Vent Using Outside Air

Table 13. Termination Clearances for Sidewall Direct Vent			
	Type of Clearance	Canadian Installations 1	US Installations 2
A	Clearance above grade, veranda, porch, deck or balcony	12 inches (30 cm)	12 inches (30 cm)
B	Clearance to window or door that may be opened	<ul style="list-style-type: none"> 6 in (15 cm) for appliances ≤ 10,000 Btuh (3 kW) 12 in (30 cm) for appliances > 10,000 Btuh (3 kW) and ≤ 100,000 Btuh (30 kW) 36 in (91 cm) for appliances > 100,000 Btuh (30 kW) 	4 feet (1.2 m) below or to side of opening; 1 foot (30 cm) above opening
C	Clearance to permanently closed window	6 inches (15 cm)*	6 inches (15 cm)*
D	Vertical clearance to ventilated soffit located above the terminal within a horizontal distance of 2 feet (61 cm) from the center line of the terminal	12 inches (30 cm)	12 inches (30 cm)
E	Clearance to unventilated soffit	12 inches (30 cm)	12 inches (30 cm)
F	Clearance to outside corner	2 feet (60 cm)*	2 feet (60 cm)*
G	Clearance to inside corner	18 inches (45 cm)*	18 inches (45 cm)*

Table 13. Termination Clearances for Sidewall Direct Vent			
	Type of Clearance	Canadian Installations 1	US Installations 2
H	Clearance to each side of center line extended above meter/regulator assembly	3 ft (91 cm) within a height 15 ft (4.6 m)	Clearance in accordance with local installation codes and the requirements of the gas supplier
I	Clearance to service regulator vent outlet	3 ft (1.83 m)	Clearance in accordance with local installation codes and the requirements of the gas supplier
J	Clearance to a non mechanical air supply inlet into building or combustion air inlet to any other appliance	<ul style="list-style-type: none"> 6 in (15 cm) for appliances ≤ 10,000 Btuh (3 kW) 12 in (30 cm) for appliances > 10,000 Btuh (3 kW) and ≤ 100,000 Btuh (30 kW) 36 in (91 cm) for appliances > 100,000 Btuh (30 kW) 	4 feet (1.2 m) below or to side of opening; 1 foot (30 cm) above opening
K	Clearance to a mechanical air supply inlet	6 feet (1.83 m)	3 feet (91 cm) above if within 10 feet (3 m) horizontally
L	Clearance above paved sidewalk or paved driveway located on public property	7 feet (2.13 m)†	7 ft (2.13 m) for mechanical draft systems (Category II appliances); vents for Category II and IV appliances cannot be located above public walkways or other areas where condensate or vapor can cause a nuisance or hazard
M	Clearance under veranda, porch, deck, or balcony	12 inches (30 cm) ‡	12 inches (30 cm) ‡

1 In accordance with the current CSA B149.1, *Natural Gas and Propane Installation Code*.

2 In accordance with the current ANSI Z223.1/NFPA 54, *National Fuel Gas Code*.

† A vent shall not terminate directly above a sidewalk or paved driveway that is located between two single family dwellings and serves both dwellings where it may cause hazardous frost or ice accumulations on adjacent property surfaces.

‡ Permitted only if veranda, porch, deck, or balcony is fully open on a minimum of two sides beneath the floor.

INSTALLING THE VENT SYSTEM

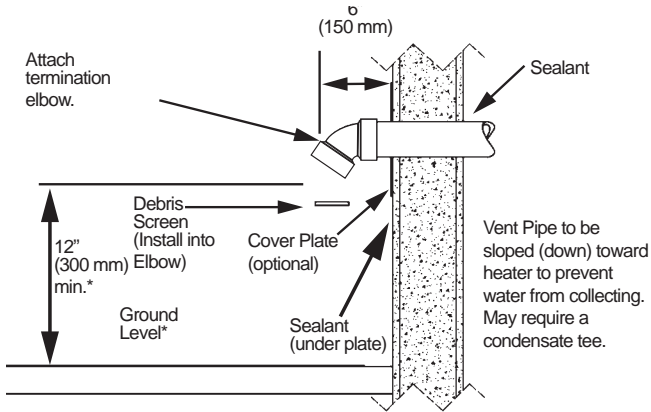

*Where snow cover is normal during winter, ensure outlet is installed above the anticipated snow level.

Figure 42. Side-Wall Vent Termination - Normal Snow Cover

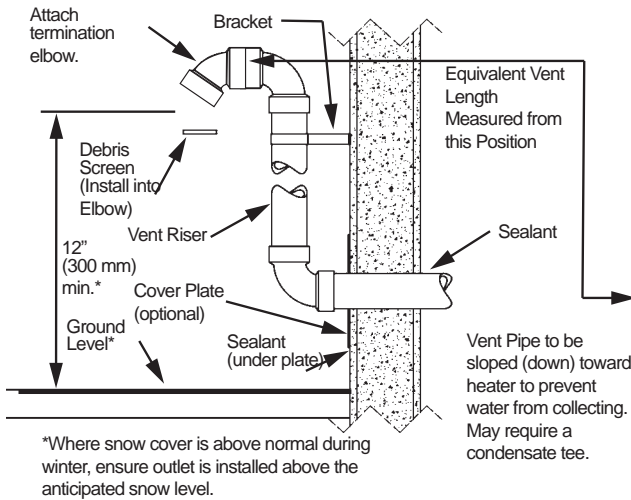

*Where snow cover is above normal during winter, ensure outlet is installed above the anticipated snow level.

Figure 43. Side-Wall Vent Termination - Above Normal Snow Cover

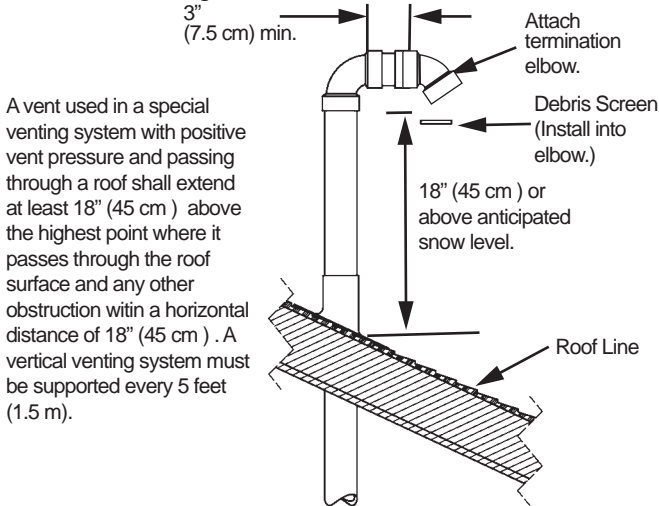

A vent used in a special venting system with positive vent pressure and passing through a roof shall extend at least 18" (45 cm) above the highest point where it passes through the roof surface and any other obstruction within a horizontal distance of 18" (45 cm). A vertical venting system must be supported every 5 feet (1.5 m).

Figure 44. Roof Vent Termination

INSTALLING THE VENT SYSTEM

CALCULATING EQUIVALENT FEET (PV)

Table 14. Calculating Equivalent Feet (PV)						
Water Heater Model	Heater Input (Btu/Hr)	Vent Size (Inside Diam.)	Pressure Switch Settings (in. w.c.)		Max. Equivalent Vent Length	Min. Equivalent Vent Length
			Intake (Nat/LP)	Exhaust (Nat/LP)		
40 gal.	50,000	2"	-1.88/-1.62	1.8/1.43	60 ft. (18.3 m) + termination	7 ft. (2.1 m) + termination
50 gal.	65,000		-1.88/-1.62	1.8/1.43		
40 gal.	50,000	3"	-1.88/-1.62	1.8/1.43	150 ft. (45.7 m) + termination	10 ft. (3.0 m) + termination
50 gal.	65,000		-1.88/-1.62	1.8/1.43		
40 gal.	50,000	4"	-1.88/-1.62	1.8/1.43	180 ft. (54.8 m) + termination	15 ft. (4.6 m) + termination
50 gal.	65,000		-1.88/-1.62	1.8/1.43		

Notes:

- All vent pipe material must be schedule 40.
- Snorkel termination elbows' equivalent lengths **must** be deducted from total vent length.
- Concentric vent terminations are not available for PV installations.
- Use long radius elbows where possible. Minimum distance between 90° elbows should be 6" (150 mm) wherever possible.
- Venting systems may use a maximum of five (5) 90° elbows.
- Use proper screen termination.

VENT INSTALLATION

- Carefully inspect the entire venting system for any signs of cracks or fractures, particularly at joints between elbows and other fittings and straight runs of vent pipe.
- Check system for signs of sagging or other stresses in joints as a result of misalignment of any components in the system. If any of these conditions are found, they must be corrected in accordance with the venting instructions elsewhere in this manual before completing installation and putting the water heater into service.
- The vent piping shall be connected to the condensate trap with a rubber coupling and secured with gear clamps. The condensate trap, pressure switch, soft tubing, coupling, and clamps are provided with the heater in the vent kit. The soft tubing is used to connect the condensate trap to the outlet air pressure switch. Ensure that the tubing is connected from the condensate trap to the outlet air pressure switch aluminum tubing located next to the condensate trap. See *Figure 26* (page 25).

CONDENSATE (EXHAUST)

This appliance is a condensing unit and will have condensate build up throughout the exhaust venting system. The vent pipe should be sloped upwards (1/4" per foot) away from the water heater. Adequate means for draining back to the condensate trap and disposing of the condensate must be made by the

installer. Condensation in the venting system is dependent upon installation conditions including, but not limited to:

- ambient temperature and humidity of installation location,
- ambient temperature and humidity of venting space,
- vent discharge and slope,
- product usage.

Note: Do not use the condensation trap as a support point. It not designed to carry the load or stresses of the venting system. Vent piping must be supported adequately and not put any weight on the condensation trap.

Connect a suitable condensate drain line to the port on the condensate trap using a 1/2" FNPT connector. The condensate line must be horizontal or inclined towards the drain. Ensure the drain line terminates at a drain as condensate will flow from the end. Ensure that any discharge will exit the condensate drain line near a suitable building drain, or external to the building.

Note: In cold climates it is recommended the condensate drain be terminated at a suitable drain inside the building.

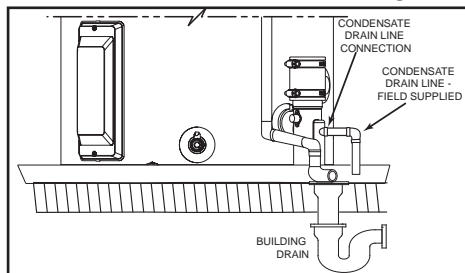

Figure 45. Condensate Drain Piped to Floor Drain

Caution must be used to ensure that drain is free and clear of debris and will not allow back-flow through the condensate drain line. If the condensate does not drain properly it will build up in the exhaust (vent) tee. This will restrict the flow of flue gases and cause the Blocked Exhaust pressure switch to open its contacts. The control system monitors all pressure switches, if the Blocked Exhaust Switch contacts are open the control system will lock out and disable heating operation. The "Blocked Exhaust" Fault code will be displayed on the control system's LCD.

Note: If the "Blocked Exhaust" Fault code is ever displayed on the control system LCD, check the condensate drain first and ensure it is not blocked.

DO NOT remove, modify or alter the factory installed exhaust/condensate tee for any reason. See *Figure 45*. The water heater's vent pipe is under a slight positive pressure while unit is in operation. The water trap inside of the exhaust/condensate tee prevents flue gases from escaping into the installed space.

INSTALLING THE WATER HEATER

DO NOT install any external condensate trap. The exhaust tee assembly has an internal condensate trap built in.

- Care should be taken to ensure there is no kink or twist in the condensate hose.
- Condensate hose must be free and clear of debris and must not allow back flow through drain line.
- Condensate must be able to flow freely to an appropriate drain.
- Do not allow condensate hose to become crimped closed.
- The condensate drain hose must not be elevated above the connection on the condensate trap.
- Condensate from this water heater is mildly acidic (pH levels between 4.3 and 5.0). Please note that some local codes require that condensate be treated by using a pH neutralizing filter prior to disposal. Condensate neutralizer kits are available. Contact your distributor or Service Agency.

WATER LINE CONNECTIONS

To reduce the risk of unusually hot water reaching the fixtures in the house, install Thermostatic Mixing Valves at each point-of-use.

The water piping installation must conform to these instructions and to all local and national code authority having jurisdiction. Good practice requires that all heavy piping be supported.

Read and observe all requirements in the following sections before installation of the water piping begins:

1. *Thermostatic Point-of-Use Mixing Valves.*
2. *Temperature-Pressure Relief Valve* (page 37).
3. *Closed Water Systems and Thermal Expansion* (page 36).

THERMOSTATIC POINT-OF-USE MIXING VALVES

⚠ CAUTION

Property Damage Hazard



Improper installation of electrical connections can cause the water heater to catch fire.

Do the following to avoid this hazard:

- Make electrical connections properly, according to the instructions.
- Use 10 gauge solid copper wire.
- Use a UL listed or CSA approved strain relief.
- Connect ground wire to green ground screw.



Figure 46. Thermostatic Point of Use Mixing Valve

⚠ DANGER

Burn Hazard



Water temperature over 125°F (52°C) can cause severe burns instantly resulting in severe injury or death.

Observe the following precautions to avoid this hazard:

- Children, the elderly, and the physically or mentally disabled are at highest risk for scald injury.
- Feel water before bathing or showering.
- Temperature limiting devices, such as thermostatic point-of-use mixing valves must be installed when required by codes and to ensure safe temperatures at fixtures.
- The thermostat(s) on this water heater has been factory set to approximately 120°F to reduce the risk of scalding. Higher temperatures increase the risk of scalding, but even at 120°F, hot water can scald. If you choose a higher temperature, thermostatic mixing valves, located at each point-of-use are particularly important to help avoid scalding.
- Thermostatic mixing valves located at each point of use are particularly important to avoid scalding.

Water heated to a temperature which satisfies space heating, clothes washing, dish washing, and other sanitizing needs can scald and cause permanent injury upon contact. Short repeated heating cycles caused by small hot-water uses can cause a temperature increase of the hot water above the heater's temperature settings.

In addition to using lowest possible temperature setting that satisfies demand of application, to reduce the risk of scalding, install Thermostatic Mixing Valves (temperature limiting valves) at each point-of-use. See *Figure 46* (page 35).

These valves automatically mix hot and cold water to limit the temperature at the tap. Thermostatic Mixing Valves are available from your local plumbing supplier. Consult a Qualified Installer or Service Agency. Follow mixing valve manufacturer's instructions for installation of the valves. Before changing the factory setting on the control system, see *Temperature Regulation* (page 47). If you choose a higher temperature setting, Thermostatic Mixing Valves located at each point-of-use are particularly important to help avoid scalding. See *Figure 46*.

Some people are more likely to be permanently injured by hot water than others. These include the elderly, children, the infirm and the physically/mentally disabled. *Table 15* (published by U.S. Government Memorandum, 1978) shows the approximate time-to-burn relationship for normal adult skin. If anyone using hot water provided by the water heater being installed fits into one of these groups, special precautions must be taken.

In all cases, the following burn table must be used.

INSTALLING THE WATER HEATER

Table 15. Burn Time at Various Temperatures

Water Temperature °F (°C)	Time for 1st Degree Burn (Less Severe Burns)	Time for Permanent Burns 2nd & 3rd Degree (Most Severe Burns)
110 (43)	(normal shower temp.)	
116 (47)	(pain threshold)	
116 (47)	35 minutes	45 minutes
122 (50)	1 minute	5 minutes
131 (55)	5 seconds	25 seconds
140 (60)	2 seconds	5 seconds
149 (65)	1 second	2 seconds
154 (68)	instantaneous	1 second

(U.S. Government Memorandum, C.P.S.C., Peter L. Armstrong, Sept. 15, 1978)

In addition to using lowest possible temperature setting that satisfies demand of application, to reduce the risk of scalding, install Thermostatic Mixing Valves (temperature limiting valves) at each point-of-use. See *Figure 45* (page 34).

These valves automatically mix hot and cold water to limit the temperature at the tap.

Thermostatic Mixing Valves are available from your local plumbing supplier. Consult a Qualified Installer or Service Agency. Follow mixing valve manufacturer's instructions for installation of the valves. Before changing the factory setting on the control system, see *Temperature Regulation* (page 47).

⚠ WARNING

Toxic Chemical Hazard

Connecting the water heater to a non-potable water system might result in chemical or biological contamination of the water heater.

Do not connect the water heater to a non-potable water system.

CLOSED WATER SYSTEMS

Water supply systems may, because of code requirements or such conditions as high line pressure, among others, have installed devices such as pressure reducing valves, check valves, and back flow preventers. Devices such as these cause the water system to be a closed system.

THERMAL EXPANSION

As water is heated, it expands (thermal expansion). In a closed system the volume of water will grow when it is heated. As the volume of water grows there will be a corresponding increase in water pressure due to thermal expansion. Thermal expansion can cause premature tank failure (leakage). This type of failure is not covered under the limited warranty. Thermal expansion can also cause intermittent temperature-pressure relief valve operation: water discharged from the valve due to excessive pressure build up. This condition is not covered under the limited warranty. The temperature-pressure relief valve is not intended for the constant relief of thermal expansion.

A properly sized thermal expansion tank should be installed on all closed systems to control the harmful effects of thermal expansion. Contact a local plumbing service agency to have a thermal expansion tank installed.

⚠ CAUTION

Property Damage Hazard

A water heater installed in a closed water system can be damaged by normal variations in pressure.

If the water heater is to be installed in a closed water system, install a thermal expansion tank or device to prevent pressure changes from damaging the water heater.

Contact a qualified installer or service agency.

Do not apply heat to the cold water inlet.

Note: To protect against untimely corrosion of hot and cold water fittings, it is strongly recommended that dielectric unions or couplings be installed on this water heater (see *Figure 47*) when connected to copper pipe.

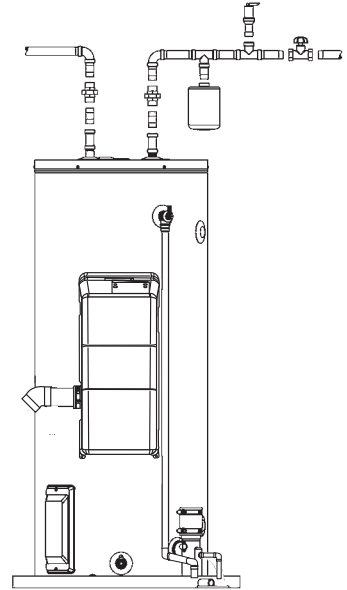

Figure 47. Using Dielectric Unions or Couplings

Figure 47 also shows the typical attachment of the water piping to the water heater. The water heater is equipped with 3/4" NPT connections for all models.

INSTALLING THE WATER HEATER

Note: If using copper tubing, solder tubing to an adapter before attaching the adapter to the water heater connections. Do not solder the water lines directly to the water heater connections. It will damage the tank, T&P Valve and Pipe Insulation (if supplied).

Fit pipe insulation over the incoming cold water line and the hot water line. Make sure that the insulation is against the top cover of the heater. Fit T&P valve insulation over valve. Make sure that the insulation does not interfere with the lever of the T&P valve. Secure all insulation using tape.

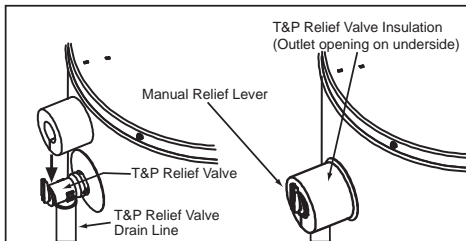

Figure 48. Installing Insulation Over T&P Valve

TEMPERATURE-PRESSURE RELIEF VALVE

This water heater is provided with a properly rated/sized and certified combination Temperature-Pressure Relief Valve (T&P relief valve) by the manufacturer. The valve is certified by a nationally recognized testing laboratory that maintains periodic inspection of production of listed equipment of materials as meeting the requirements for *Relief Valves for Hot Water Supply Systems, ANSI Z21.22 • CSA 4.4*, and the code requirements of ASME. If replaced, the new T&P valve must meet the requirements of local codes, but not less than a combination Temperature-Pressure Relief Valve rated/sized and certified as indicated in the previous paragraph. The new valve must be marked with a maximum set pressure not to exceed the marked hydrostatic working pressure of the water heater (150 psi / 1,035 kPa) and a discharge capacity not less than the water heater Btu/hr or kW input rate as shown on the water heater's model rating plate.

Note: In addition to the factory installed Temperature-Pressure Relief Valve on the water heater, each remote storage tank that may be installed and piped to a water heating appliance must also have its own properly sized, rated and approved Temperature-Pressure Relief Valve installed.

⚠ CAUTION

Property Damage Hazard

High temperature or pressure in the water heater can cause the water heater to explode resulting in severe injury or death.

- A properly sized temperature-pressure relief valve must be installed in the opening provided.
- The temperature-pressure relief valve must comply with *ANSI Z21.22-CSA4.4* and *ASME* code.
- Do not plug, block, or cap the discharge line.

For safe operation of the water heater, the Temperature-Pressure Relief Valve must not be removed from its designated opening nor plugged. The Temperature-Pressure Relief Valve must be installed directly into the fitting of the water heater designed for the Temperature-Pressure Relief Valve. Install discharge piping so that any discharge will exit the pipe 6" above an adequate floor drain, or external to the building. In cold climates it is recommended that it be terminated at an adequate drain inside the building. Be certain that no contact is made with any live electrical part. The discharge opening must not be blocked or reduced in size under any circumstances.

Excessive length, over 30', or use of more than four elbows can cause restriction and reduce the discharge capacity of the valve.

No valve or other obstruction is to be placed between the Temperature-Pressure Relief Valve and the tank. Do not connect discharge piping directly to the drain. To prevent bodily injury, hazard to life, or property damage, the temperature-pressure relief valve must be allowed to discharge water in adequate quantities should circumstances demand. If the discharge pipe is not connected to a drain or other suitable means, the water flow may cause property damage.

The purpose of a Temperature-Pressure Relief Valve is to prevent excessive temperatures and pressures in the storage tank. The T&P valve is not intended for the constant relief of thermal expansion. A properly sized thermal expansion tank must be installed on all closed systems to control thermal expansion. See *Closed Water Systems* and *Thermal Expansion* (page 36).

T&P Valve Discharge Pipe

⚠ CAUTION

Property Damage Hazard

The temperature-pressure relief valve can intermittently discharge hot water throughout the normal operation of the water heater, which can cause water damage.

Locate the water heater so that the discharge pipe terminates at an adequate and suitable drain.

- Shall not be smaller in size than the outlet pipe size of the valve, or have any reducing couplings or other restrictions.
- Shall not be plugged or blocked.
- Shall not be exposed to freezing temperatures.
- Shall be of material listed for hot water distribution.
- Shall be installed so as to allow complete drainage of both the Temperature-Pressure Relief Valve and the discharge pipe.
- Must terminate 6" above a floor drain or other safe place. In cold climates, it is recommended that the discharge pipe be terminated at an adequate drain inside the building.
- Shall not have any valve or other obstruction between the Temperature-Pressure Relief Valve and the drain

⚠ DANGER

Burn Hazard

The discharge from the temperature-pressure relief valve can be hot enough to burn.

Keep your hands clear of the temperature-pressure relief valve discharge outlet.

INSTALLING THE WATER HEATER

SPACE HEATING APPLICATIONS

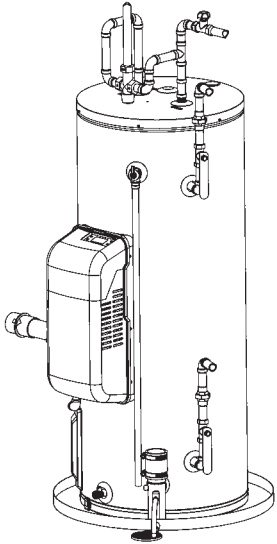

Figure 49. Water Heater with Side Taps for Space Heating

This appliance has been design certified as complying with *American National Standards* for water heaters and is suitable for combination water (potable) heating and space heating but not space heating only applications.

Note: When there will be no domestic hot water demand for an extended period of time, the temperature set point should be set at 90°F to prevent “Stacking” and T&P discharge.

This heater is equipped with additional side taps for use in space heating applications. See *Features and Components* (page 13) for locations. If this water heater is to be used to supply both space heating and potable (drinking) water, the instructions listed below must be followed:

⚠ WARNING

Toxic Chemical Hazard

Use of chemical piping sealers or connecting the water heater to a non-potable water system might result in chemical or biological contamination of the water heater.

Do the following to avoid contaminating the water heater:

- Do not connect the water heater to a non-potable water system.
- Do not use piping that has been treated with chromates, boiler seal, or other chemicals.

Consult a Qualified Installer or Service Agency. Follow manufacturer’s instructions for installation of valves. Before changing the factory setting on the control system, see

Temperature Regulation (page 47). Water piping and vent piping occupy the space above the water heater. Plan the water piping to ensure it does not cause interference with the vent piping. See *Combustion Air and Ventilation* (page 21).

If this water heater is to be used to supply both space heating and potable water, the instructions listed below must be followed:

- Be sure to follow the manual(s) shipped with the air handler or other type heating system.
- This water heater is not to be used as a replacement for an existing boiler installation.
- Do not use with piping that has been treated with chromates, boiler seal or other chemicals and do not add any chemicals to the water heater piping.
- If the space heating system requires water temperatures higher than required for domestic water purposes, install a Thermostatic Mixing Valve in the domestic (potable) hot water supply at each point-of-use to limit the risk of scald injury. See *Figure 46* (page 35).
- Pumps, valves, piping and fittings must be compatible with potable water.
- A properly installed flow control valve is required to prevent thermosiphoning. Thermosiphoning is the result of a continuous flow of water through the air handler circuit during the off cycle. Weeping (blow off) of the temperature-pressure relief valve (T&P) or higher than normal water temperatures are the first signs of thermosiphoning.
- The hot-water line from the water heater should be vertical past any mixing valve or supply line to the heating system to remove air bubbles from the system.
- Do not connect the water heater to any system or components previously used with non-potable water heating appliances when used to supply potable water.

Combo Heating

This section serves as a guide for the installation and use of “Combo” heating systems utilizing a domestic water heater that has been specifically approved for such use. It is written for those knowledgeable in the required trades and professionals involved in the design and installation of Combo Heating Systems.

It is the responsibility of the installer/designer to follow all applicable codes to ensure the effectiveness and safety of the installation.

Your water heater is equipped with Combo Heating capabilities and are shipped with the two side plumbing taps **PLUGGED** (items 24 and item 29 in *Figure 3* (page 13)). See also *Figure 49* (page 38). If the heater is to be operated using the side taps for combo heating, these plugs must be removed.

System Requirements

The following requirements must be met for the installation of Combo Heating Systems:

1. All components used for the distribution of water in the heating loop must be suitable for potable water. These include all piping, fittings, solder and fluxes, pumps for circulation of water, valves, etc.
2. The water heater must not be connected to a hydronic heating system that has been used previously. This heater is not designed to be used in a space heating only application.
3. No boiler treatment chemicals of any kind shall be introduced into the system.
4. The Combo System components must be selected and sized to meet and maintain the total calculated demands for both domestic service hot water and space heating requirement. The sizing and installation must be performed in accordance with good engineering practice such as “ASHRAE Handbooks”, HRAI’s Unified Combo Guidelines, “Hydronics Institute Manuals”, ANSI Z223.1, CSA F280, National/Provincial Building Codes, ANSI and/or codes having jurisdiction.
5. The air handler (fan coil) and/or the circulating pump in a baseboard hydronic loop will require a dedicated 120 Vac circuit. This must be provided and identified for this purpose.
6. All piping between the water heater and the air handler or hydronic baseboard loop must be adequately insulated to reduce heat loss.
7. If the local jurisdiction requires a back-flow preventer in the cold water line, an expansion tank of adequate size must be installed.
- 8.

INSTALLING THE WATER HEATER

- “Combo” Heating Systems require higher water temperatures than other applications. When the system is used to supply water for Combo Heating applications, a means, such as Thermostatic Mixing Valves at each point-of-use, must be installed to temper the water in order to reduce scald hazard potential. See *Figure 50* and *Figure 51*.

Combo Heating Installation

The heating mode may be one of the following options:

- A fan coil/air handler. See *Figure 50* (page 39).
- A hydronic baseboard (finned tube) loop/ In floor heating. See *Figure 50* (page 39).

The following is a list of requirements for the installation of option A or B.

- Install shut-off valves and unions so that the water heater can be isolated from the heating module should servicing of the water heater become necessary.
- Install a drain valve at the lowest point of the heating loop so that water can

be drained from the heating module without affecting the water heater.

- If the air handler does not have a venting means at the highest point of the piping arrangement, install an air bleed at the highest point of the plumbing arrangement.

Install a spring loaded check valve in the space heating return line to prevent cold water from continuously entering the water heater. Failure to install such a valve could cause “stacking” and cause the T&P valve to open.

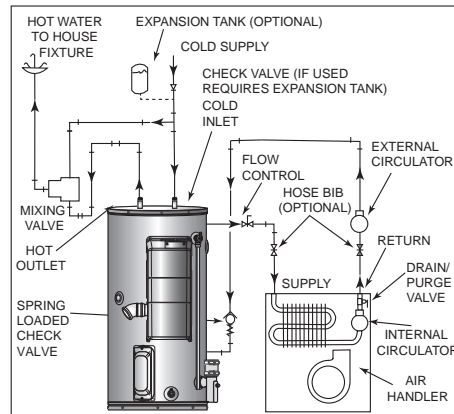

Figure 50. Typical Combo Heating Configuration

See also *Massachusetts Installation Requirements* (page 12).

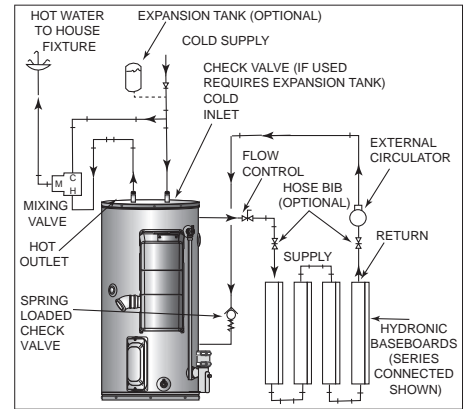

Figure 51. Typical Combo Heating with Hydronic Baseboards

ELECTRICAL INSTALLATION

Grounding Instructions

This water heater must be grounded in accordance with the *National Electrical Code* and/or local codes. These codes must be followed in all cases. Failure to ground this water heater properly may also cause erratic control system operation.

This water heater must be connected to a grounded metal, permanent wiring system; or an equipment grounding conductor must be run with the circuit conductors and connected to the equipment grounding terminal or lead on the water heater.

Electrical Supply

The water heaters covered in this manual require a 120 Vac, 1Ø (single phase), 60 Hz, 10 amp power supply and must also be electrically

grounded in accordance with local codes or, in the absence of local codes, with the *National Electrical Code, NFPA 70*.

If any of the original wire as supplied with the water heater must be replaced, it must be replaced with 105°C rated wiring or its equivalent, except in the burner housing. In this case 200°C rated wire must be used.

Dedicated Power Wiring and Breakers

Dedicated power supply wires, ground wiring and dedicated circuit breakers often prevent electrical line noise and should be considered when installing the water heater.

Power Fluctuations and Electrical Noise

The water heater’s control system requires a source of stable clean electricity for proper operation. Connecting the water heater to a branch circuit that is subject to fluctuations in voltage level or electrical line noise such as EMI (electromagnetic interference) or RFI (radio frequency interference) may cause erratic control system operation and malfunction.

A high quality power supply filter/suppressor must be installed if the above conditions exist. Call the technical support phone number for more information.

Note: Malfunctions caused by the power supply and the costs to install the power supply filters are not covered under the limited warranty.

INSTALLING THE WATER HEATER

Electrical Wiring

If you lack the necessary skills required to properly install the electrical wiring to this water heater, do not proceed but have a qualified electrician perform the installation. See *Electrical Supply* (page 39) for additional requirements.

When making the electrical connections, always make sure:

- The voltage and frequency must correspond to that specified on the water heater data plate on the front of the water heater.
- The electrical supply has the proper overload fuse or breaker protection. The heater draws less than 10 amps.
- Wire sizes, connections and conduits comply with all applicable codes.
- The water heater and electrical supply are properly grounded.
- This water heater must be “hard-wired” do not use an extension cord to supply electrical power to this water heater.

Note: The wiring diagram can be found in *Diagrams* (page 58). Always reference the wiring diagram(s) for the correct electrical connections.

Making the Electrical Connections

⚠ WARNING

Electrical Shock Hazard

 Servicing this water heater can expose you to electrical current capable of causing severe injury or death.

- Disconnect power before servicing.
- Replace all parts and panels before operating.
- Failure to do so can result in e death or electrical shock.

Before plugging in the water heater, always make sure:

- The voltage and frequency correspond to that specified on the water heater wiring diagram.

- The electrical outlet has the proper overload fuse or breaker protection.
1. The unit must be connected to a 120 VAC power supply. A dedicated circuit is preferred. Do not use a GFI outlet.
 2. The water heater must be properly grounded.
 3. This water heater is a polarity sensitive appliance and will not operate if the power supply polarity is reversed.

Note: Note: Always reference the wiring diagram for the correct electrical connections.

After making all electrical connections, completely fill the tank with water and check all connections for leaks. Open the nearest hot-water faucet and let it run for 3 minutes to purge the water lines of air and sediment and to ensure complete filling of the tank. The electrical power may then be turned on. Verify proper operation after servicing. See also *Installation Checklist* (page 44).

GAS SUPPLY SYSTEM INSTALLATION

Low pressure building gas supply systems are defined as those systems that cannot under any circumstances exceed 14” w.c. (3.5 kPa). These systems do not require pressure regulation. Measurements should be taken to insure that gas pressures are stable and fall within the requirements stated on the water heater rating plate.

⚠ WARNING

Fire and Explosion Hazard

 Attempting to use the wrong type of gas or excessive gas pressure with the water heater might cause it to explode and catch fire, resulting in property damage, personal injury, or death.

Do the following to avoid this hazard:

- Use the type of gas specified for this water heater on its rating label only.
- Use a pressure reducer valve to match gas supply line pressure to the water heater’s rated pressure.
- Turn off gas lines during installation.
- Contact a qualified installer or service agency for installation and service.

Readings should be taken with all gas burning equipment off (static pressure) and with all gas burning equipment running at maximum rate (dynamic pressure). The gas supply pressure must be stable within 1.5” w.c. (0.37 kPa) from static to dynamic pressure to provide good performance. Pressure drops that exceed 1.5”

w.c. (0.37 kPa) may cause rough starting, noisy combustion or nuisance outages. Increases or spikes in static pressure during off cycles may cause failure to ignite or in severe cases damage to water heater gas control valves. If your low pressure system does NOT meet these requirements, the installer is responsible for the corrections.

High pressure building supply systems use pressures that exceed 14” w.c. These systems must use field supplied regulators to lower the gas pressure to less than 14” w.c. Water heaters require gas regulators that are properly sized for the water heater input and deliver the rating plate specified pressures. Gas supply systems where pressure exceeds 5 psi often require multiple regulators to achieve desired pressures. Systems in excess of 5 psi building pressure should be designed by gas delivery professionals for best performance. Water heaters connected to gas supply systems that exceed 14” w.c. at any time must be equipped with a gas supply regulator.

All models require a minimum gas supply pressure of 3.5” W.C. for natural gas and 8.0” W.C. for propane. The minimum supply pressure is measured while gas is not flowing (static pressure) AND while gas is flowing (dynamic pressure). The supply pressure (static and dynamic) should never fall below 3.5” w.c. for natural gas and 8.0” W.C. for propane. The supply pressure should be measured with all gas fired water heaters connected to the common

main firing at full capacity. If the supply pressure drops more than 1.5” w.c. as gas begins to flow to the water heater then the supply gas system including the gas line and/or the gas regulator may be restricted or undersized. See *Gas Supply Regulator* (page 40) and *Gas Line Installation* (page 41). The gas control valve on all models has a maximum gas supply pressure limit of 14” w.c. The maximum supply pressure is measured while gas is not flowing (static pressure) AND while gas is flowing (dynamic pressure).

Gas Supply Regulator

The maximum allowable gas supply pressure for this water heater is 14” w.c. Install a positive lock-up gas pressure regulator in the gas supply line if inlet gas pressure can exceed 14” w.c. at any time. Regulators must be sized/used according to manufacturer’s specifications.

If a positive lock-up regulator is required follow these instructions:

1. Positive lock-up gas pressure regulators must be rated at or above the input Btu/hr rating of the water heater they supply.
2. Supply gas regulators shall have inlet and outlet connections not less than the minimum supply gas line size for the water heater they supply.
3. Positive lock-up gas pressure regulator(s) should be installed no closer than 3’

INSTALLING THE WATER HEATER

and no farther than 8' from the water heater's inlet gas connection.

- After installing the positive lock-up gas pressure regulator(s) an initial nominal supply pressure setting of 7.0" w.c. for Natural Gas and 11.0" w.c. for Propane (LP) while the water heater is operating is recommended and will generally provide good water heater operation. Some additional adjustment may be required later to maintain a steady gas supply pressure.
- When installing multiple water heaters in the same gas supply system it is recommended that individual positive lock-up gas pressure regulators be installed at each unit.

All gas piping must comply with local codes and ordinances or with current editions of the *National Fuel Gas Code, ANSI Z223.1/NFPA 54*. Copper or brass tubing and fittings (except tin lined copper tubing) shall not be used.

If the gas control valve is subjected to pressures exceeding 1/2 psi, the damage to the gas control valve could result in a fire or explosion from leaking gas.

If the main gas line Shut-off serving all gas water heaters is used, also turn off the gas at each water heater. Leave all gas appliances shut off until the water heater installation is complete.

A gas line of sufficient size must be run to the water heater. Consult the current edition of the *National Fuel Gas Code, ANSI Z223.1/NFPA 54* and your gas supplier concerning pipe size.

There must be:

- A readily accessible manual shut off valve in the gas supply line serving the water heater, and
- A sediment trap ahead of the gas control valve to help prevent dirt and foreign materials from entering the gas control valve.
- A ground joint union of proper size between the manual shut off valve and gas control valve to permit servicing of the unit.

Be sure to check all the gas piping for leaks before lighting the water heater. Rinse off solution and wipe dry.

Gas Line Installation

Contact your local gas utility company to ensure that adequate gas service is available and to review applicable installation codes for your area.

⚠ WARNING

Fire and Explosion Hazard

Under certain circumstances, the water heater can explode and catch fire, resulting in property damage, personal injury, or death.

Do the following to avoid these conditions:

- Do not store or use gasoline or other flammable vapors and liquids in the vicinity of this or any other appliance.
- Avoid all ignition sources if you smell gas.
- Do not expose water heater controls to excessive gas pressure.
- Use only the gas shown on the water heater rating label.
- Maintain required clearances to combustibles.
- Keep ignition sources away from faucets after extended periods of non-use.
- Install sediment trap in accordance with *NFPA54* or *CSA-B1491*.
- Read the instruction manual before installing, using, or servicing the water heater.
- Contact a qualified installer or service agency for installation and service.

Be sure that the gas meter has sufficient capacity to supply the rated gas input of the water heater as well as the requirements of all other gas fired equipment supplied by the meter. If the gas meter is undersized, the gas company will have to install a properly sized gas meter.

Make sure the gas supplied is the same type listed on the water heaters rating label.

The gas piping must be installed according to all local and state codes or in absence of local and state codes with the current edition of the *National Fuel Gas Code, ANSI Z223.1/NFPA 54*.

Schedule 40 Steel or Wrought Iron Pipe is the preferred material for the gas line of this water heater. It is imperative to follow the sizing recommendations in the latest version of the *National Fuel Gas Code, ANSI Z223.1/NFPA 54* if corrugated stainless steel tubing (CSST) is used as the gas line for this water heater.

Table 6 (page 23), Table 11 (page 30), and Table 14 (page 34), and Table 16 (page 42) are provided as a sizing reference for commonly used gas pipe materials. Consult the *National Fuel Gas Code* for the recommended gas pipe size of other materials.

⚠ WARNING

Fire and Explosion Hazard

Contaminants in gas lines can cause fire or explosion.

Do the following to avoid this hazard:

- Clean all gas piping before installation.
- Install sediment trap in accordance with *NFPA54* or *CSA-B1491*.
- Be sure the junction box cover and the access door covers are in place.
- These covers keep debris from entering and potentially being ignited, and help keep any internal fires from spreading.

Follow the instructions below and see *Figure 52* and *Figure 53* for gas piping installation.

- Apply thread sealing compounds (pipe dope/thread-sealer tape) sparingly and only to the male threads of the pipe joints. Do not apply sealing compound to the first two threads. Use pipe dope or thread-sealer tape marked as being resistant to the action of liquid petroleum (LP/propane) gases.
- Install a readily accessible manual shut-off valve in the gas supply line as recommended by the local utility. Know the location of this valve and how to turn off the gas to this unit.
- Install a sediment trap as shown. The sediment trap must be no less than 3" long for the accumulation of dirt, foreign material and water droplets.
- Install a ground union between the water heater and the manual shut-off valve. This is to allow easy servicing. See *Figure 53* (page 42).
- Turn the gas supply on and check for leaks. See *Gas Supply Line Leak Testing* (page 43).

Note: Units with inputs of 175,000 BTU/hr or above must have a minimum of 3/4" NPT gas pipe supplied to the water heater.

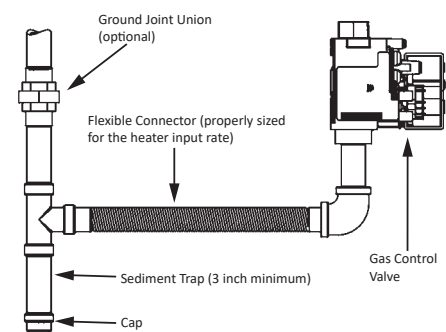
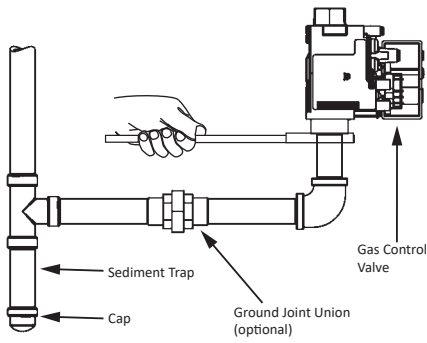

Figure 52. Flexible Pipe to Gas Valve

INSTALLING THE WATER HEATER



Note: Always secure the square on the gas valve base with a suitable wrench when tightening or loosening the gas piping.

Figure 53. Black Pipe to Gas Valve

Gas Line Sizing

Depending on the developed equivalent length and/or the number of appliances connected to a common main, the size of supply gas lines may have to be increased.

Size the supply/main gas line(s) in accordance with *Table 16* or *Table 17*.

The values given in *Table 16* and *Table 17* are for straight lengths of iron pipe at 0.5" W. C. (125 Pa) pressure drop, which is considered normal for low pressure systems.

Note: Fittings such as elbows and tees will add to the pipe pressure drop.

Schedule-40 Steel or wrought-iron pipe is the preferred material for the gas line of this water heater. It is imperative to follow the sizing recommendations in the latest version of the *National Fuel Gas Code* if corrugated stainless steel tubing (CSST) is used as the gas line for this water heater.

Table 16. Supply Gas Line Sizing U. S. Units

Length in Feet	Normal Iron Pipe Sizes (Inches) Input In Thousands Btu/Hr					
	1/2"	3/4"	1"	1 1/4"	1 1/2"	2"
10	175	360	680	1400	2100	3960
20	120	250	485	950	1460	2750
30	97	200	375	770	1180	2200
40	82	170	320	660	990	1900
50	73	151	285	580	900	1680
60	66	138	260	530	810	1520
70	61	125	240	490	750	1400
80	57	118	220	460	690	1300
90	53	110	205	430	650	1220
100	50	103	195	400	620	1150
125	44	93	175	360	550	1020
150	40	84	160	325	500	950
175	37	77	145	300	460	850
200	35	72	135	280	430	800

INSTALLING THE WATER HEATER

Table 17. Supply Gas Line Sizing Metric Units

Length In Meters	Normal Iron Pipe Sizes (inches) Input in kW					
	1/2"	3/4"	1"	1 1/4"	1 1/2"	2"
3.0	51	105	199	410	615	1160
6.1	35	73	142	278	428	805
9.1	28	59	110	225	346	644
12.2	24	50	94	193	290	556
15.2	21	44	83	170	264	492
18.3	19	40	76	155	237	445
21.3	18	37	70	143	220	410
24.4	17	35	64	135	202	381
27.4	16	32	60	126	190	357
30.5	15	30	57	117	182	337
38.1	13	27	51	105	161	299
45.7	12	25	47	95	146	278
53.3	11	23	42	88	135	249
61.0	10	21	40	82	126	234

Gas Supply Line Leak Testing

Any time work is done on the gas supply system perform a leak test to avoid the possibility of fire or explosion.

1. For test pressures exceeding 1/2 psi disconnect, the water heater and its Main Gas Shutoff Valve from the gas supply piping system during testing. See *Figure 2* (page 13). The gas supply line must be capped when disconnected from the water heater.
2. For test pressures of 1/2 psi or less, the water heater need not be disconnected, but must be isolated from the supply gas line by closing the Main Gas Shutoff Valve during testing.
3. Paint all supply gas line joints and connections upstream of the water heater with a chloride-free liquid solution to test for leaks. Bubbles indicate a gas leak. Do not use matches, candles, flame or other sources of ignition for this purpose.
4. Repair any leaks before placing the water heater in operation.

Gas Supply Line Purging

Gas line purging is required with new piping or systems. Purging should be performed per the current edition of the *National Fuel Gas Code, ANSI Z223.1/NFPA 54*.

Water Heater Gas Leak Testing

The following are procedure guidelines for detecting gas leaks in gas water heater connections, including the gas valve, the valve train, and other system components.

A chloride-free liquid solution is the only approved fuel gas or combustion product leak verification method. Paint suspected leak points with a liquid solution to test for leaks. Bubbles indicate a fuel gas or combustion product leak. Do not use matches, candles, flame or other sources of ignition for this purpose.

Use of a leak-detection device shall be limited to identification of a potential source of leakage with the actual leak confirmed by using a chloride-free liquid solution as described above. When using a leak-detection device the tip of the probe shall be no less than 2" (50 mm) from the suspected leak point. If no leak is detected with a leak detection device, no verification is required with a liquid solution.

Note: Servicing should only be performed by a qualified service technician.

HIGH ALTITUDE INSTALLATIONS

This high efficiency water heater is certified for use without modification for an altitude of 10,100 feet (3,078 m). Consult the factory for installation at altitudes over 10,100 feet (3,078 m).

WARNING

Breathing Hazard



Breathing carbon monoxide can cause brain damage or death.

Do the following to avoid carbon monoxide poisoning:

- Install vent system in accordance with codes.
- Special consideration must be taken with installations above 10,100 ft. (3,079 m). Refer to the high altitude section of this manual.
- Do not operate if there is soot build-up.
- Do not obstruct water heater air intake with insulating jacket or blanket.
- Do not place chemical vapor emitting products near the water heater.
- Gas and carbon monoxide detectors are available.
- Never operate the heater unless it is vented to the outdoors and has adequate air supply to avoid risks of improper operation, fire, explosion, or asphyxiation.
- Analyze the entire vent system to make sure that condensate will not become trapped in a section of vent pipe and therefore reduce the open cross sectional area of the vent.
- Always read and understand instruction manual.

Some gas utility companies derate their gas for altitude, making it unnecessary to install high altitude orifices. Call the local gas or utility company to verify BTU content.

Due to the input rate reduction at high altitudes, the output rating of the water heater is also reduced and should be compensated for in the sizing of the equipment for applications. See *Combustion Air and Ventilation* (page 21).

CONNECTING THE WATER SUPPLY

Note that all piping and components connected to the water heater must be suitable for use with potable water.

1. Determine the type of water pipes in your home. Most homes use copper water pipes, but some use CPVC or cross-linked polyethylene (PEX). Use fittings appropriate for the type of pipe in your home. Do not use iron or PVC pipe – they are not suitable for potable water.
2. Connect the cold water supply using 3/4 inch National Pipe Thread "NPT" to the cold water inlet nipple.

For ease of removing the water heater for service or replacement, connect the water pipes with a coupling called a union. We recommend using a dielectric-type union (available at your local

INSTALLING THE WATER HEATER

plumbing supplier). Dielectric unions can help prevent corrosion caused by tiny electric currents common in copper water pipes and can help extend the life of the water heater.

NOTICE: Most water heater models contain energy saving heat traps in the inlet and outlet connections. Do not remove the heat traps.

3. Connect the hot water supply using 3/4" NPT to the hot water outlet. Follow the same connection guidelines as for the cold water supply.
4. Install insulation (or heat tape) on the water pipes especially if the indoor

installation area is subject to freezing temperatures. Insulating the hot water pipes can increase energy efficiency.

5. Adjust (or install) the home's Pressure Reducing Valve to 50-60 psi and install a Thermal Expansion Tank.



Figure 54. A Pressure Reducing Valve is required if your

home's water pressure is above 80 psi.



Figure 55. The Thermal Expansion Tank should be pressurized with air to match the home's incoming water pressure.

INSTALLATION CHECKLIST

Note: Use and complete this checklist before lighting the heater. Correct any conditions that do not meet these instructions.

Water Heater Location

- Centrally located with the water piping system. Located as close to gas piping and vent pipe system as possible.
- Located indoors and in a vertical position. Protected from freezing temperatures.
- Proper clearances from combustible surfaces maintained and not installed directly on a carpeted floor.
- Provisions made to protect the area from water damage. Metal drain pan installed and piped to an adequate drain.
- Installation area free of corrosive elements and flammable material.
- Sufficient room to service the water heater.

Gas Supply And Piping

- Gas supply is the same type as listed on the water heater data plate.
- Gas line equipped with shut-off valve, union and sediment trap.
- Approved pipe joint compound used.
- Adequate pipe size and of approved material.

- Chloride-free solution or other approved means used to check all connections and fittings for possible gas leaks.

Vent Pipe System

- Vent pipe and fittings of approved material.
- Acceptable size, length and number of elbows on exhaust vent system.
- Installed in accordance with prevailing provisions of local codes, or in the absence of such, the latest edition of *National Fuel Gas Code, ANSI Z223.1/NFPA 54*.
- Horizontal piping slopes at an upward pitch of 1/8" rise per 5' away from the water heater.
- Not obstructed in any way.
- Means installed to collect, neutralize (if required) and dispose of condensate.

Vent Termination

Horizontal

- 12" min. above grade/snow level.
- Away from corners, other vents, windows etc.

Vertical

- Air Intake and Exhaust terminations 18" min. above roof/snow level.

Water System Piping

- Temperature and Pressure relief valve properly installed with a discharge line run to an open drain and protected from freezing.
- All piping properly installed and free of leaks.
- Heater completely filled with water.
- Closed system pressure build-up precautions installed.
- Thermostatic Mixing Valves installed at each point-of-use.

Electrical Connections

- Unit connected to a 120 V electrical supply. A dedicated circuit is preferred. Do not use a GFI outlet.
- Proper polarity.
- Water heater properly grounded.
- Installed in accordance with prevailing provisions of local codes, or in the absence of such, the latest edition of *National Electrical Code (NFPA 70)*.

After all actions on checklist are checked/completed, read the Lighting Instructions and proceed with lighting the heater.

START UP AND OPERATIONS

START UP CONDITIONS

⚠ CAUTION

Property Damage Hazard



A water heater installed in a closed water system can be damaged by normal variations in pressure.

If the water heater is to be installed in a closed water system, install a thermal expansion tank or device to prevent pressure changes from damaging the water heater.

Contact a qualified installer or service agency.

SMOKE/ODOR

It is not uncommon to experience a small amount of smoke and odor during the initial start-up. This is due to burning off of oil from metal parts, and will disappear in a short while.

PRIOR TO START UP

Installation and start up of this water heater requires abilities and skills equivalent to that of a licensed tradesman in the field involved. See *Qualifications* (page 10).

DO NOT USE THIS APPLIANCE IF ANY PART HAS BEEN EXPOSED TO FLOODING OR WATER DAMAGE. Immediately call a qualified service technician to inspect the water heater and to make a determination on what steps should be taken next.

Light the water heater in accordance with the Lighting and Operation Instruction label on the water heater and in this manual.

The water heaters covered by this manual are equipped with an electronic control system which automatically sequences the Combustion Blower, pre- and post-purging of the combustion chamber, the Hot Surface Igniter, the 24 Volt Gas Control Valve, Main Burner Ignition, and flame sensing. The control system will lock out after three unsuccessful ignition attempts. The control will reset itself after 15 minutes. See *Control System Operation* (page 49).

Before attempting start up, thoroughly study and familiarize yourself with the exact sequence of operation. See *Basic Sequence Of Operation* (page 55), *Burner Ignition Sequence* (page 55). Ensure the water heater is properly grounded. Flame sensing requires an adequate earth ground. If the water heater is not properly grounded it will cause Ignition Failure. See *Electrical Wiring* (page 40).

Be certain that the water heater is full of water, that air is purged from the gas and water lines and that there are no leaks in the gas and water lines. Ensure all inlet water valves are open.

FILLING THE WATER HEATER

⚠ CAUTION

Property Damage Hazard



Operating the water heater without water will cause damage to it.

To avoid water heater damage, fill tank with water before operating.

Never use this water heater unless it is completely full of water. To prevent damage to the tank, the tank must be filled with water. Water must flow from the hot water faucet before turning ON gas to the water heater.

To fill the water heater with water:

1. Locate the drain valve at the base of the water heater behind the access panel. See *Features and Components* (page 13).
2. Close the water heater drain valve by turning the handle to the right (clockwise).
3. Open the cold water supply valve to the water heater.

Note: The cold water supply valve must be left open when the water heater is in use.

4. To insure complete filling of the tank, allow air to exit by opening the nearest

hot water faucet. Allow water to run until a constant flow is obtained. This will let air out of the water heater and piping.

5. Check all water piping and connections for leaks. Repair as needed. See *Checking for leaks* (page 57).

INITIAL START UP

Required Test Equipment

- One U-tube manometer, recommended ranges; 0-14" w.c. and 0-35" w.c. or pressure gauges.
- One digital manometer can be used in place of U-tube manometers or pressure gauges. Recommended ranges; -14.00 to +14.00" w.c. resolution 0.01" w.c. and 0-35" w.c. resolution 0.10" w.c.

Note: All test equipment must be acclimated to ambient temperature before calibration and use.

Preparation

1. Using the control system menus, change the temperature setpoint to the lowest temperature setting. See *Temperature Setpoint* (page 49).
2. Close the manual gas shut off valve. See *Figure 2* (page 13).
3. Wait five (5) minutes for any residual gas to clear.
4. Open the Main Gas Shutoff Valve.
5. Measure and record the supply gas pressure, this is a "static" supply gas pressure reading; while the water heater is not firing. Adjust supply gas pressure as necessary. See *Gas Supply System Installation* (page 40).

Lighting The Water Heater

The instruction label below is affixed to the factory and must be followed when lighting and water heater's covered by this manual at the operating the water heater.

FOR YOUR SAFETY READ BEFORE LIGHTING	POUR VOTRE SÉCURITÉ, LISEZ AVANT L'ALLUMAGE
  <p>WARNING: If you do not follow these instructions exactly, a fire or explosion may result causing property damage, personal injury or loss of life.</p> <p>AVERTISSEMENT: Tout manquement aux présentes directives peut causer un incendie ou une explosion résultant en des dommages matériels, des blessures ou la mort.</p>	
<p>BEFORE OPERATING: ENTIRE SYSTEM MUST BE FILLED WITH WATER AND AIR PURGED FROM ALL LINES.</p> <p>A. This appliance does not have a pilot. It is equipped with an ignition device which automatically lights the burner. Do NOT try to light the burner by hand.</p> <p>B. BEFORE OPERATING smell all around the appliance area for gas. Be sure to smell next to the floor because some gas is heavier than air and will settle on the floor.</p> <p>WHAT TO DO IF YOU SMELL GAS:</p> <ul style="list-style-type: none"> Do not try to light any appliance. Do not touch any electric switch; Do not use any phone in your building. Immediately call your gas supplier from a neighbor's phone. Follow the gas suppliers instructions. If you cannot reach your gas supplier, call the fire department. <p>C. Use only your hand to push in the control module buttons. Never use tools. If the control buttons will not push in, don't try to repair them, call a qualified service technician. Force or attempted repair may result in a fire or explosion.</p> <p>D. Do not use this appliance if any part has been under water. Immediately contact a qualified installer or service agency to replace a flooded water heater. Do not attempt to repair the unit. It must be replaced!</p>	<p>AVANT LA MISE EN MARCHÉ: LE RÉSEAU D'ALIMENTATION EN EAU DOIT ÊTRE ENTIÈREMENT REMPLI D'EAU ET L'AIR ENTIÈREMENT PURGÉ.</p> <p>A. Cet appareil n'est pas équipé d'une veilleuse. Le brûleur est plutôt muni d'un dispositif d'allumage automatique. NE tentez PAS d'allumer le brûleur manuellement.</p> <p>B. AVANT LA MISE EN MARCHÉ, humez tout autour de l'appareil afin de déceler une éventuelle odeur de gaz. Sentez aussi près du sol, car certains gaz sont plus lourds que l'air et s'y accumulent. SI VOUS DÉTECTEZ UNE ODEUR DE GAZ:</p> <ul style="list-style-type: none"> Ne mettez aucun appareil en marche. Ne pas toucher à aucun interrupteur; ne pas se servir des téléphones se trouvant dans le bâtiment. Appelez immédiatement votre fournisseur de service du gaz de chez un voisin et suivez ses directives. Si vous ne pouvez communiquer avec votre fournisseur de gaz, appelez le service des incendies. <p>C. Ne vous servez que de vos mains pour appuyer sur les boutons du module de commande, n'utilisez jamais d'outils. Si vous n'arrivez pas à actionner les boutons du module de commande, ne tentez pas de les réparer. Faites plutôt appel à un technicien d'entretien qualifié. Si vous forcez ou tentez de réparer le bouton, il a risque d'explosion ou d'incendie.</p> <p>D. N'utilisez pas cet appareil même s'il n'a été que partiellement submergé par de l'eau. Communiquez immédiatement avec un installateur qualifié ou un centre de service afin de faire remplacer tout chauffe-eau ayant été submergé lors d'une inondation. Ne tentez jamais de réparer l'appareil. Il doit être remplacé!</p>
OPERATING INSTRUCTIONS	INSTRUCTIONS D'UTILISATION
<ol style="list-style-type: none"> STOP!  Read the safety information above on this label. Unplug the power cord from the 120Vac 60Hz outlet. This appliance is equipped with a device which automatically lights the burner. Do not try to light the burner by hand. Set the Main Manual Gas Shut-Off Valve to the OFF position. Wait five (5) minutes to clear out any gas. If you then smell gas, STOP!  Follow "B" in the safety information above on this label. If you don't smell gas, go to the next step. Set the Main Manual Gas Shut-Off Valve to the ON position. Plug the power cord into a 120Vac 60Hz outlet. Turn ON the heater by pressing the  (ON/OFF) button for 3 seconds. If the "Lock" icon on the display is showing, press the  (Lock/Unlock) button for 5 seconds to unlock the control. The default setpoint for water temperature is 60°C (140°F). To change this setting, press the  (Plus) or  (Minus) button repeatedly until the desired water temperature is indicated on the display. Press the  (Lock/Unlock) button within 10 seconds to accept the new water temperature setpoint.  DANGER Hotter water increases the risk of scald injury. Consult the instruction manual before changing temperature. If the appliance will not operate, follow the instructions "TO TURN OFF GAS TO APPLIANCE" and call your technician or gas supplier. 	 <ol style="list-style-type: none"> ARRÊTEZ!  Lisez les directives de sécurité au haut de cette étiquette. Débranchez le cordon d'alimentation de la prise électrique 120 Vca/60 Hz. Le brûleur de cet appareil est muni d'un dispositif d'allumage automatique. Ne tentez pas d'allumer le brûleur manuellement. Poussez l'interrupteur de la commande du gaz à la position "OFF". Attendez cinq minutes afin de laisser se dissiper tout gaz ayant pu s'accumuler. Si vous détectez une odeur de gaz, ARRÊTEZ!  Passez à l'étape B des instructions de sécurité dans la partie supérieure de cette étiquette. Si vous ne détectez pas d'odeur de gaz, passez à la prochaine étape. Poussez l'interrupteur de la commande du gaz à la position "ON". Branchez le cordon d'alimentation à une prise électrique 120 Vca/60 Hz. Lancez le chauffage en appuyant sur le bouton  (ON/OFF) pendant 3 secondes. Si l'icône "Verrou" s'affiche à l'écran, appuyez sur le bouton  (Verrouiller/Déverrouiller) pendant 5 secondes pour déverrouiller le module de commande. La température de consigne par défaut est de 60°C (140°F). Pour modifier ce paramètre, appuyez plusieurs fois sur le  bouton (Plus) ou (Moins) jusqu'à ce que la température de l'eau souhaitée s'affiche à l'écran.  Appuyez sur le bouton (Verrouiller/Déverrouiller) dans les 10 secondes pour accepter la nouvelle température de consigne.  DANGER plus l'eau est chaude, plus le risque d'ébouillantage est élevé. Consultez les directives du manuel à ce sujet avant de régler la température. Si l'appareil ne se met pas en marche, suivez la directive "COUPER L'ALIMENTATION EN GAZ DE L'APPAREIL" et appelez un technicien ou le fournisseur de gaz.
TO TURN OFF GAS TO APPLIANCE	COUPER L'ALIMENTATION EN GAZ DE L'APPAREIL
<ol style="list-style-type: none"> Unplug the power cord from the 120Vac 60Hz outlet if service is to be performed. Set the Main Manual Gas Shut-Off Valve to the OFF position. 	<ol style="list-style-type: none"> Débranchez le chauffe-eau de la prise 120 Vca/60 Hz lors de tout entretien. Débranchez le chauffe-eau de la prise 120 Vca/60 Hz lors de tout entretien.
100321847	

Figure 56. Lighting Instructions Label

TEMPERATURE REGULATION

Install Thermostatic Mixing Valves to regulate the temperature of the water supplied to each point-of-use (for example, kitchen sink, bathroom sink, bath, shower). Install and adjust the mixing valve according to its manufacturer's instructions. See *Figure 46* (page 35).



It is recommended that lower water temperatures be used to avoid the risk of scalding. It is further recommended, in all cases, that the water temperature be set for the lowest temperature which satisfies your hot-water needs. This will also provide the most energy efficient operation of the water heater.

Short repeated heating cycles caused by small hot-water uses can cause a temperature increase of the hot water by 30F° higher than the heater's temperature settings. If you experience this type of use you should consider using lower temperature settings to reduce scald hazards.

WARNING! Even if the water heater's control system is set to a relatively low temperature, hot water can scald. Install Thermostatic Mixing Valves at each point-of-use to reduce the risk of scalding. See *Figure 46* (page 35).

Should overheating occur or the gas supply fails to shut off, turn off the main manual gas shut off valve to the appliance. See *Figure 2* (page 13).

TEMPERATURE CONTROL

 DANGER	
Burn Hazard	
	Water temperature over 125°F (52°C) can cause severe burns instantly resulting in severe injury or death.
Observe the following precautions to avoid this hazard:	
<ul style="list-style-type: none">• Children, the elderly, and the physically or mentally disabled are at highest risk for scald injury.• Feel water before bathing or showering.• Temperature limiting devices, such as thermostatic point-of-use mixing valves must be installed when required by codes and to ensure safe temperatures at fixtures.• The thermostat(s) on this water heater has been factory set to approximately 120°F to reduce the risk of scalding. Higher temperatures increase the risk of scalding, but even at 120°F, hot water can scald. If you choose a higher temperature, thermostatic mixing valves, located at each point-of-use are particularly important to help avoid scalding.• Thermostatic mixing valves located at each point of use are particularly important to avoid scalding.	



HOT WATER CAN SCALD

Water heaters are intended to produce hot water. Water heated to a temperature which will satisfy space heating, clothes washing, dish washing, cleaning and other sanitizing needs can scald and permanently injure you upon contact. Some people are more likely to be permanently injured by hot water than others. These include the elderly, children, the infirm, or physically/mentally handicapped. If anyone using hot water fits into one of these groups or if there is a local code or state law requiring certain temperature water at the hot-water tap, then you must take special precautions. In addition to using lowest possible temperature setting that satisfies demand of application, to reduce the risk of scalding, install Thermostatic Mixing Valves (temperature limiting valves) at each point-of-use. See *Figure 46* (page 35). These valves automatically mix hot and cold water to limit the temperature at the tap. Before changing the factory setting on the control system, see *Table 18*.

This water heater is equipped with a control system. See *Figure 57* (page 49). Hot water temperatures required for automatic dishwasher and laundry use can cause scald burns resulting in serious personal injury and/

or death. The temperature at which injury occurs varies with the person's age and time of the exposure. The slower response time of children, aged or disabled persons increases the hazards to them. Never allow small children to use a hot-water tap, or to draw their own bath water. Never leave a child or disabled person unattended in a bathtub or shower.

Setting the water heater temperature at 120 °F will reduce the risk of scalds.

 WARNING	
Burn Hazard	
	Higher temperatures over 120°F (49°C) can cause severe burns instantly resulting in severe injury or death.
To reduce the risk of unusually hot water reaching the fixtures in the house, install thermostatic mixing valves at each point of use.	

See *Figure 46* (page 35)

TEMPERATURE REGULATION

Table 18. Burn Time at Various Temperatures

Water Temperature °F (°C)	Time for 1st Degree Burn (Less Severe Burns)	Time for Permanent Burns 2nd & 3rd Degree (Most Severe Burns)
110 (43)	(normal shower temp.)	
116 (47)	(pain threshold)	
116 (47)	35 minutes	45 minutes
122 (50)	1 minute	5 minutes
131 (55)	5 seconds	25 seconds
140 (60)	2 seconds	5 seconds
149 (65)	1 second	2 seconds
154 (68)	instantaneous	1 second

(U.S. Government Memorandum, C.P.S.C., Peter L. Armstrong, Sept. 15, 1978)

⚠ DANGER

Burn Hazard

Higher temperatures over 120°F (49°C) can cause severe burns instantly resulting in severe injury or death.

To reduce the risk of unusually hot water reaching the fixtures in the house, install thermostatic mixing valves at each point of use.

Check water temperature at several points of use in your home (for example, bathtub faucet, shower, or lavatory sink) and adjust the Thermostatic Mixing Valves as needed. See *Figure 46* (page 35).

The water heater should be located in an area where the general public does not have access to set temperatures.

Setting the water temperature setpoint at 120°F will reduce the risk of scalds. Some states require

settings at specific lower temperatures. Check with the code authority having jurisdiction.

The water heaters covered in this manual are equipped with an electronic control system to regulate water temperature inside the storage tank. The control system senses temperature from a factory installed temperature probe installed on the side of the storage tank. See *Figure 2* (page 13) and *Figure 3* (page 13).

The water temperature setpoint is adjusted to regulate water temperature inside the tank. This is an adjustable user setting in the control system's "Temperature Menu." This and all control system menus are accessed through the UIM (user interface module) located on the front of the water heater. See *Figure 57* (page 49).

The water temperature setpoint is adjustable from 90°F (32°C) to 160°F (71°C). The factory setting is 120°F (49°C). See *Temperature Setpoint* (page 49) for instructions on how to adjust the setpoint and other settings.

Set the water temperature setpoint at the lowest setting which produces acceptable hot water supply. This will always provide the most efficient operation.

Note: When there will be no domestic hot water demand for an extended period of time, the temperature set point should be set at 90°F to prevent "Stacking" and T&P discharge.

HIGH TEMPERATURE APPLICATIONS

Higher operating temperatures cause more wear on all water heaters and will decrease the life span of the water heater. Consider installing a small booster water heater for high temperature applications to raise the outlet temperature from the larger primary water heater to the desired point of use temperature. Contact your local distributor or call technical

support phone number listed on front page of this manual for further technical assistance.

HIGH TEMPERATURE LIMIT CONTROL (ECO)

This water heater is equipped with an ECO (energy cut out) non-adjustable high-temperature limit designed to protect against excessively high water temperatures inside the water heater's storage tank. The Control board constantly monitors the state of the temperature sensor thermistors. If the ECO activates due to abnormally high water temperature (approximately 190°F), the Control Board will lock out and display fault code E00 on the UIM.

If the ECO activates due to abnormally high water temperatures in the storage tank, the control system will immediately de-energize the Gas Control Valve and end current heating cycle. The control system will lock out disabling further heating operation. It is important that a Qualified Service Technician be contacted to determine the reason for ECO activation before resetting the ECO. Once the reason has been determined and corrected the ECO can be reset as follows:

If the ECO activates, water temperature must drop below 140°F before the control system can be reset. Once water temperature has cooled below this point, the Control Board must be reset. To reset the Control Board, do the following:

1. Unlock the buttons (by pressing the Lock/Unlock button for 3 seconds), if the interface is locked
2. Simultaneously press the ON/OFF and Plus (SW3) buttons for 3 seconds.

See *Figure 57* (page 49) for the button locations.

CONTROL SYSTEM OPERATION

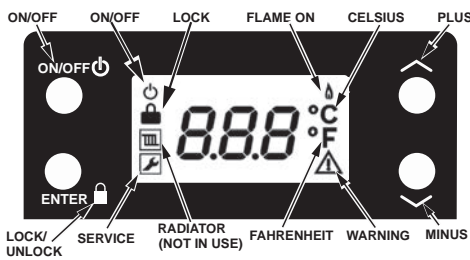





Figure 57. LCD Display

ICONS



- ON/OFF: visible when heater has power but is OFF.
- LOCK: visible when keypad locked.
- RADIATOR: not used
- SERVICE: visible when heater is in service modes.
- FLAME: visible when burner is in run mode.
- CELSIUS: visible when a temperature is shown and the unit is °C.
- FAHRENHEIT: visible when a temperature is shown and the unit is °F.
- WARNING: flashing during fault conditions.

BUTTONS

-  (ON/OFF) - This button is used to switch On/Off the heater.
-  (Lock/Unlock) - This button is used to Lock/Unlock the control.
-  (Plus and Minus) - These two buttons are used to make changes of the setpoint and to navigate throughout the menus.



Combinations of the buttons are used for other functions, as per the following paragraphs:

ON/OFF





When the heater is OFF the only active (unlocked) button is the  button. The LCD display shows only the ON/OFF icon. This icon informs the user that the heater is connected to electric power. When in OFF, the heater completely ignores the call for heat and never ignites the burner. The user can turn the heater ON by pressing the  button for 3 seconds.

When the heater is ON, the ON/OFF icon is not shown. Setpoint/Error codes are shown on LCD. Lock/Unlock, °C, °F, flame, service and warning icons are active and shown according to heater status and setting.



LOCK/UNLOCK

The control can be locked either by pressing the  button for 3 seconds or automatically after 30 seconds without pressing any button. When the control is locked the LCD will return to display the setpoint (or error code if in a fault state). When the control is locked and any button is pressed the lock icon on LCD will flash twice per second. To unlock the control press  button for 5 seconds and the lock icon on LCD will turn off. When the control is locked the Temperature setpoint cannot be changed and the operating mode cannot be changed.

TEMPERATURE SETPOINT

To adjust the temperature setpoint, unlock the control and press the  or  buttons until reaching the desired value. The new value will flash on the LCD display twice per second. To validate the new setpoint, short press the  button. If the  button is not pressed within 10 seconds, the new value will start to flash on the display, and the setpoint goes back to the previous value being continuously shown on LCD.



NORMAL MODE / VACATION MODE

The user can quickly change from the normal mode to the vacation mode (and vice versa) by pressing the  and  buttons simultaneously. In vacation mode the setpoint is 60°F and the differential is 10F° independently of the outdoor temperature. In Normal mode the LCD will display the actual setpoint set by the user, in Vacation mode the LCD will display the vacation setpoint.

BURNER IN OPERATION

When the burner is in operation and the flame is detected by the flame sensor, the flame icon on LCD is on.



SWITCHING BETWEEN TEMPERATURE UNITS

To switch temperature units (°F/°C), unlock the control and press  button and the  button simultaneously. The corresponding icon on LCD °F or °C will be on.





FAULT INDICATION



If an error condition exists or a warning is in place, the LCD shows the setpoint for 1 second and error code for 1 second. The warning icon will flash once per second.

SERVICE MODE

To enter in the service mode, Unlock the control and simultaneously press the  and  buttons for 3 seconds. In service mode the service icon is on. While in service mode, pressing the  buttons allows for cycling between service codes. The numeric display will show the service code for 1 second, followed by the actual measurement displayed for 3 seconds.

Example: H06-5.00 represents the service code of “H06 Blower RPM target” and the value of “5.00” is the blower speed (5.00x1000 = 5,000 rpm).

The display will continue to show the service code and the measurement value unless the  or  buttons are pressed to cycle to the next item. To exit Service mode once again simultaneously press the  and  buttons for 3 seconds. If no button is pressed for 30 seconds the unit will revert back to operation mode where the setpoint is displayed and the control is locked.

Simultaneously pressing the  and  buttons again will confirm the new altitude setting and also exit altitude setting and revert back to “Service mode”.

MAINTENANCE

Table 19. Maintenance Schedule

Component	Operation	Interval	Reference
Tank	Drain and Flush	Every 6 Months	See <i>Draining and Flushing</i> .
Tank	Lime Scale Removal (Water Less Than 25 Grains Hard)	Not Required	N/A
Tank	Lime Scale Removal (Water Greater Than 25 Grains Hard)	Annually	See <i>Lime Scale Removal</i> .
Burner Flames	Inspection	Every 3 Months	See <i>Burner Operation And Inspection</i> (page 51).
Burner	Inspection/Cleaning	As Needed	Contact qualified agency or professional.
Moving Parts	Lubrication	Not Required	N/A
Powered Anodes	Inspection/Cleaning	Annually	See <i>Anode Rod Maintenance</i> (page 52).
T&P Valve	Test Operation	Semi Annually	See <i>Temperature-Pressure Relief Valve Test</i> (page 52).
Vent System	Inspection	Annually	See <i>Venting System Inspection</i> .
Condensate Neutralization	Inspection	Annually	See manual for the condensate neutralization kit.
Condensate Collection	Cleaning	Annually	See <i>Venting System Inspection</i> .

VENTING SYSTEM INSPECTION

WARNING

Fire and Explosion Hazard



Flu gases, which can contain carbon monoxide, can escape if the vent pipe is not properly installed. Breathing carbon monoxide can cause brain damage or death.

Do the following to prevent this:

- Be alert for an obstructed, sooted, or deteriorated vent system.
- Do not store corrosive chemicals in the vicinity of the water heater because they can cause chemical corrosion of the flue and vent system.
- Analyze the entire vent system to make sure that condensate will not become trapped in a section of vent pipe and therefore reduce the open cross sectional area of the vent.
- Always read and understand the instruction manual.
- Install gas and carbon monoxide detectors in the vicinity of the water heater.

At least once a year a visual inspection should be made of the venting system. You should:

- Check for obstructions and/or deterioration of the intake air and/or vent piping and the intake air and vent terminations. The combustion and ventilation air flow must not be obstructed. Repair and/or replace immediately as necessary.

Note: Do not reach inside the vent termination while the heater is in operation.

- Remove any debris that may have accumulated on the screen in the vent terminations.

- Check all vent system connections for damage or deterioration which could cause improper venting or leakage of combustion products. Repair or reseal as necessary.

Be sure the vent piping is properly connected to prevent escape of dangerous flue gasses which could cause deadly asphyxiation.

Obstructions and deteriorated vent systems may present serious health risk or asphyxiation.

Chemical vapor corrosion of the flue and vent system may occur if air for combustion contains certain chemical vapor. Spray can propellants, cleaning solvents, refrigerator and air conditioner refrigerants, swimming pool chemicals, calcium and sodium chloride, waxes, bleach and process chemicals are typical compounds which are potentially corrosive.

If after inspection of the vent system you found sooting or deterioration, something is wrong. Call the local gas utility to correct the problem and clean or replace the flue and venting before resuming operation of the water heater.

DRAINING AND FLUSHING

It is recommended that the water heater storage tank be drained and flushed every 6 months to reduce sediment buildup. The water heater should be drained if being shut down during freezing temperatures. See *Figure 2* (page 13) and *Figure 3* (page 13) for the location of the water heater components described below.

DANGER

Burn Hazard



The discharge from the temperature-pressure relief valve can be hot enough to burn.

Keep your hands clear of the temperature-pressure relief valve discharge outlet.

Draining the Storage Tank

1. Unplug the water heater from the electrical supply.
2. Turn off the gas supply at the Main Gas Shutoff Valve if the water heater is going to be shut down for an extended period. See *Figure 2* (page 13).
3. Ensure the cold water inlet valve is open.
4. Open a nearby hot water faucet and let the water run until the water is no longer hot.
5. Close the cold water inlet valve to the water heater.
6. Connect a hose to the water heater drain valve and terminate it to an adequate drain.
7. Open the water heater drain valve and allow all the water to drain from the storage tank.
8. Close the water heater drain valve when all water in the storage tank has drained.
9. Close the hot water faucet opened in *Step 4*.
10. If the water heater is going to be shut down for an extended period, the drain valve should be left open.

Flushing the Storage Tank

1. Unplug the water heater from the electrical supply.
2. Ensure the cold water inlet valve is open.
3. Open a nearby hot water faucet and let the water run until the water is no longer hot. Then close the hot water faucet.
4. Connect a hose to the drain valve and terminate it to an adequate drain.
5. Ensure the drain hose is secured before and during the entire flushing procedure. Flushing is performed with system water pressure applied to the water heater.
6. Open the water heater drain valve to flush the storage tank.

MAINTENANCE

7. Flush the water heater storage tank to remove sediment and allow the water to flow until it runs clean.
8. Close the water heater drain valve when flushing is completed.
9. Remove the drain hose.
10. Fill the water heater. See *Filling the Water Heater* (page 45).
11. Reconnect the water heater to the electrical supply to place the water heater back in operation.
12. Allow the water heater to complete several heating cycles to ensure it is operating properly.

SEDIMENT REMOVAL

Waterborne impurities consist of the particles of soil and sand which settle out and form a layer of sediment on the bottom of the tank.

For convenience, sediment removal and lime scale removal should be performed at the same time.

Lime Scale Removal

When water is heated dissolved minerals in the water such as calcium and magnesium carbonate (lime scale) become less soluble. As the water temperature rises these minerals will precipitate or “fall out” of solution.

The amount of lime scale released from water is in direct proportion to water temperature and usage. The higher the water temperature or water usage, the more lime deposits are dropped out of the water.

Water hardness also affects lime scale accumulation. With the temperature and usage being the same, hard water will release more lime scale than softer water.

Lime scale reduces heating efficiency as it accumulates inside a water heater. Heating transfer surfaces become coated with lime scale deposits which increases fuel costs to operate the water heater. Lime scale deposits can also cause rumbling and pounding noises as air molecules trapped in the lime scale

escape when heated. Lime scale accumulation also reduces the life span of water heaters. For these reasons a regular schedule for deliming should be set up.

The depth of lime accumulation in the bottom of the water heater should be measured periodically. Inspect by removing the cleanout cover once every 6 months at first. Deliming maintenance should then be performed based on the time it takes for 1 inch (2.5 cm) of lime to accumulate in the bottom of the water heater.

Chemical Lime Scale Removal

To dissolve and remove more stubborn lime scale deposits, UN-LIME® Professional Delimer should be used.

UN-LIME® Professional Delimer is an easy to handle patented food grade acid formulated specifically for lime scale removal from all types of water using equipment. Hydrochloric base acids must not be used to delime the water heaters covered in this manual.

Follow the instructions on the UN-LIME® to delime the water heater.

Note: Contact Technical Support for assistance in ordering the UN-LIME® Professional Delimer.

BURNER OPERATION AND INSPECTION

At least once a year a visual inspection should be made of the main burner and the hot surface igniter assembly for proper flame characteristics and ignition sequences. This can be done by removing the outer plastic cover. See *Figure 58* (page 51).

The main burner should provide complete combustion of gas, ignite rapidly, give reasonably quiet operation, and cause no excessive flame lifting from the burner ports. If the proper flame characteristics are not evident, make sure that the flow of combustion and ventilation air is not blocked. Inspection of exhaust/air intake termination is needed to ensure there is no blockage there.

You should also check for sooting. Soot is not normal and will impair proper combustion. A visual inspection of the main burner and hot surface igniter should also be done at least once a year. See *Figure 58* (page 51).

Soot build-up indicates a problem that requires correction before further use. Turn “OFF” gas to water heater by unplugging the power cord and leave off until repairs are made. Failure to correct the cause of the sooting can result in a fire causing death, serious injury, or property damage.

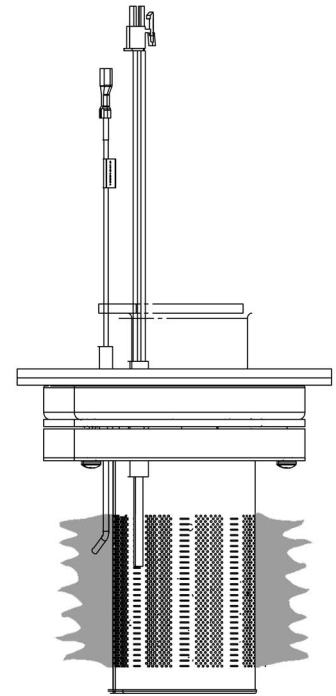

Figure 58. Burner-Blower Assembly

COMBUSTION CHAMBER AND BURNER CLEANING

In the event your burner or burner air openings require cleaning, Call your service agency to remove and clean the burner and correct the problem that required the burner to be cleaned.

MAINTENANCE

HOUSEKEEPING

⚠ WARNING

Fire and Explosion Hazard

 Flammable vapors can leak from their containers and be ignited by the water heater. The resulting fire and/or explosion can cause serious injury or death.

Do the following to avoid this hazard:

- Do not place chemical vapor emitting products near air intake and exhaust terminations.
- Do not use or store flammable vapor products, such as gasoline, solvents, or adhesives in the same room or area near the water heater or other appliances.

MAINTAIN MINIMUM CLEARANCES

To ensure sufficient ventilation and combustion air supply, proper clearances from the water heater must be maintained. See *Before you Begin* (page 16). Combustible materials such as clothing, cleaning materials, or flammable liquids, etc. must not be placed against or adjacent to the water heater which can cause a fire.

ANODE ROD MAINTENANCE

⚠ CAUTION

Property Damage Hazard

 A depleted or malfunctioning anode rod can lead to damage to the water heater

Inspect the anode or anodes annually and replace them as needed.

The anode rod is a sacrificial metal rod that helps avoid corrosion and premature failure (leaks) in the tank. The anode rod is a consumable item. Inspect the anode rod after the first six months of operation when you drain and flush the tank. Replace the anode rod if it is substantially worn out or depleted. See *Figure 59* (page 52). Thereafter, inspect the anode rod annually or more frequently if needed. If you use a water softener, your anode rod will deplete faster than normal. Inspect the anode rod more frequently, replacing the anode rod if it is depleted. Once the anode rod is depleted, the tank will start to corrode, eventually developing a leak. Obtain a new anode rod from your local plumbing supplier or have a qualified person replace it. (Anode rods are a consumable item and are not covered under warranty).

Certain water conditions will cause a reaction between the anode rod and the water. The most common complaint associated with the anode rod is a “rotten egg smell” produced from the presence of hydrogen sulfide gas dissolved in the water. The removal of the anode rod requires a 1-1/16” socket.

Important: Do not operate the water heater without a functioning anode rod as this will void any warranties. A special anode rod may be available if water odor or discoloration occurs.

Note: This rod may reduce but not eliminate water odor problems. The water supply system may require special filtration equipment from a water conditioning company to successfully eliminate all water odor problems.

Remove the anode rod for inspection at least once per year. To replace the anode:

1. Turn “OFF” the electrical supply to the water heater.
2. Turn “OFF” the gas supply at the Main Gas shut-off Valve.
3. CLOSE the cold-water inlet valve to the water heater.
4. OPEN a nearby hot-water faucet and leave open to allow for draining.
5. Drain approximately 5 gallons of water from tank. See *Draining and Flushing* for proper procedures. Close drain valve.
6. Remove old anode rod.
7. Use thread-sealer tape or approved pipe sealant on threads and install new anode rod.
8. Remove the hose and follow instructions in the *Filling the Water Heater* (page 45).
9. Follow the lighting instructions on the label or see *Lighting The Water Heater* (page 46) to restart the water heater.

See *Figure 2* (page 13) for anode rod location.

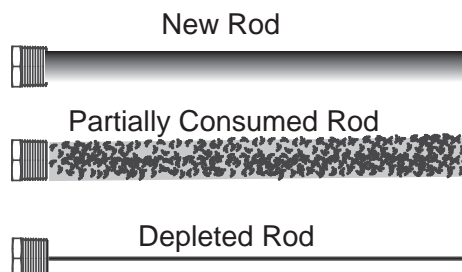



Figure 59. Anode Rod Depletion

TEMPERATURE-PRESSURE RELIEF VALVE TEST

It is recommended that the Temperature-Pressure Relief Valve be checked every 6 months to ensure that it is in operating condition. When checking the Temperature-Pressure Relief Valve operation, make sure that (1) no one is in front of or around the outlet of the Temperature-Pressure Relief Valve discharge line, and (2) that the water discharge will not cause any property damage, as the water may be extremely hot. Use care when operating valve as the valve may be hot.

⚠ DANGER

Burn Hazard

 The discharge from the temperature-pressure relief valve can be hot enough to burn.

Keep your hands clear of the temperature-pressure relief valve discharge outlet.

To check the temperature-pressure relief valve, lift the lever at the end of the valve several times (see *Figure 60*). The valve should seat properly and operate freely.

If after manually operating the valve, it fails to completely reset and continues to release water, immediately close the cold water inlet to the water heater and drain the water heater. See *Draining and Flushing* (page 50). Replace the Temperature-Pressure Relief Valve with a properly rated/sized new one. See *Temperature-Pressure Relief Valve* (page 37) for instructions on replacement.

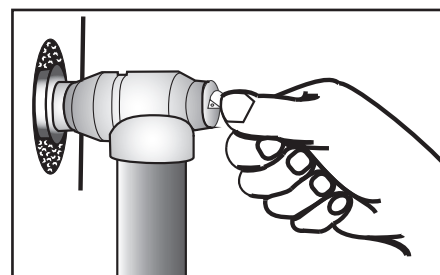

Figure 60. Testing the Temperature-Pressure Relief Valve

If the Temperature-Pressure Relief Valve on the water heater weeps or discharges periodically, this may be due to thermal expansion.

Note: Excessive water pressure is the most common cause of Temperature-Pressure Relief Valve leakage. Excessive water system pressure is most often caused by “thermal expansion” in a “closed system.” See *Closed Water Systems* and *Thermal Expansion* (page 36). The Temperature-Pressure Relief

MAINTENANCE

Valve is not intended for the constant relief of thermal expansion.

Temperature-Pressure Relief Valve leakage due to pressure build up in a closed system that does not have a thermal expansion tank installed is not covered under the limited warranty. Thermal expansion tanks must be installed on all closed water systems.

Do not plug the Temperature-Pressure Relief Valve opening. This can cause property damage, serious injury or death.

If you do not understand these instructions or have any questions regarding the Temperature-Pressure Relief Valve call the toll free number listed on the front page of this manual for technical assistance.

 **WARNING**

Fire and Explosion Hazard

 Without a temperature-pressure relief valve, the water heater might overheat or over-pressurize and explode resulting in severe injury or death.

Do the following to avoid this hazard:

- Install a properly-sized temperature-pressure relief valve in the opening provided.
- The temperature-pressure relief valve must comply with *ANSI Z21.22-CSA 4.4* and the *ASME* code.

SERVICE

If a condition persists or you are uncertain about the operation of the water heater contact a qualified service technician.

Use this guide to check a leaking water heater. Many suspected leaks are not leaking tanks. Often the source of the water can be found and corrected.

If you are not thoroughly familiar with gas codes, your water heater, and safety practices, contact your gas supplier or qualified installer to check the water heater.

Read this manual first. Then before checking the water heater make sure the gas supply has been turned "OFF", and never turn the gas "ON" before the tank is completely full of water.

TROUBLESHOOTING

SERVICE MODE

To enter in the service mode, unlock the buttons by simultaneously pressing the “Lock/Unlock” and “Minus” buttons for 3 seconds. In service mode, the “service” icon shows on the display.

While in service mode, pressing the “Plus/Minus” (SW3 & SW4) buttons cycles between service codes. The numeric display shows the service code for 1 second, followed by the actual measurement, which is displayed for 3 seconds.

Example:

H06-5.00 is the service code for “H06 Blower RPM target,” and “5.00” is the blower speed (5.00x1000 = 5,000 rpm).

The display continues to show the service code and the measurement value unless the up or down arrow button is pressed to switch to the next item.

To exit service mode, simultaneously press the “Lock/Unlock” (SW2) and “Minus” (SW4) buttons again for 3 seconds. Also, if in service

mode and no button is pressed for 30 seconds, the unit will go back to operation mode, with the setpoint on the display and the buttons locked.

Table 20. Service Code Functions

Service Code	Service Functions	Range	Unit	On LCD
H01	SW code / SW revision			H01_XXX_XXX
H02	Tank temperature	0-999	°C / °F	H02_XXX
H03	Tank temperature 2	0-999	°C / °F	H03_XXX
H04	Flame current	0-9.9	uA	H04_XX
H05	Blower rpm (actual)	1.00-9.99	(x1000) rpm	H05_XXX
H06	Blower rpm (commanded)	1.00-9.99	(x1000) rpm	H06_XXX
H07	LDM Voltage	0.00-9.99	V	H07_XXX
H08	Total Heating cycles	0-999999	-	H08_XXX_XXX
H09	Total heating time	0-999999	h	H09_XXX_XXX
H10	Total Ignition failures	0-999999	-	H10_XXX_XXX
H11	Total Flame loss failures	0-999999	-	H11_XXX_XXX
H12	Error code History 1	-	-	H12_XXX_XXX
H13	Error code History 2	-	-	H13_XXX_XXX
H14	Error code History 3	-	-	H14_XXX_XXX
H15	Error code history 4	-	-	H15_XXX_XXX
H16	Error code History 5	-	-	H16_XXX_XXX
H17	Error code History 6	-	-	H17_XXX_XXX
H18	Error code History 7	-	-	H18_XXX_XXX
H19	Error code History 8	-	-	H19_XXX_XXX
H20	Error code History 9	-	-	H20_XXX_XXX
H21	Error code History 10	-	-	H21_XXX_XXX

OUTLET AIR PRESSURE SWITCH (OAPS)

The role of the OAPS is to detect a blocked flue outlet (blocked vent). It is a normally closed switch that opens when the outlet vent is partially or totally blocked. In case it opens, the heater ceases heating mode, goes to post-purge and displays E06. Once the post-purge is over, if heat request is still present and the OAPS is closed, the system should restart and attempt to start a new heating cycle. If the OAPS opens

three times in less than 60 minutes since first occurrence the heater ceases heating mode, goes to post-purge, and displays E05. See *Clearing Error Codes* (page 56).

INTAKE AIR PRESSURE SWITCH (IAPS)

The role of the IAPS is to detect a blocked air inlet. It’s a normally closed switch that opens when the inlet vent is partially or totally blocked. In case it opens, the heater ceases

heating mode, goes to post-purge and displays E23. Once the post-purge is over, if heat request is still present and the IAPS is closed, the system should restart and attempt to start a new heating cycle. If the IAPS opens three times in less than 60 minutes since first occurrence the heater ceases heating mode, goes to post-purge and displays E22. See *Clearing Error Codes* (page 56).

TROUBLESHOOTING

BASIC SEQUENCE OF OPERATION

Call for Heat:

The control determines that a call for heat is necessary when the water temperature drops below setpoint minus the differential temperature. The call for heat is ended when the water temperature rises above setpoint. When there is no call for heat, the heater remains in standby mode.

A call for heat is determined by the following conditions:

- If tank temperature < Operating Setpoint – Differential, a call for heat is initiated.
- If tank temperature > Operating Setpoint, a call for heat is ended.

The tank temperature is the water temperature measured by the dual thermistor temperature probe.

The Setpoint is the intended temperature of the outlet water set by end user and displayed on LCD display.

Monitor Flame Current

When the heater is in pre-purge, warm-up or post-purge and the control senses a flame current, the heater will go in error mode E01 (Flame detected when it is not expected); the blower will operate at high speed until the flame current is not sensed anymore. 15 minutes after the disappearance of the flame, the control will operate normally. When the heater is in operation (burner is “on”) and the flame is lost, after the post-purge sequence the heater will initiate a new heating cycle. If the flame is lost

for 3 times in less than five minutes the heater will go in error mode (E03 lose flame 3 times in 5 minutes). See *Clearing Error Codes* (page 56).



Burner Ignition Sequence

At power up, the control board, performs an inter-purge to clean-up the combustion chamber. After this, when call for heat is not present, the heater is in STAND-BY status. After receiving a call for heat, prior pre-purge stage, the control will check for the inlet air pressure switch and outlet air pressure switch to be closed and no flame signal presence. The blower will start to operate in pre-purge stage. At the end of the pre-purge period the HSI will be energized. After 12 seconds (warm up time), the HSI reaches the ignition temperature; the gas valve will be energized (open) for the duration for 5 seconds (safety time), then the presence of the flame signal will be verified by the control. The heating mode will be maintained until the call for heat is satisfied (tank temperature reaches the Setpoint). The gas valve will be turned off (closed) and the blower will operate for the duration of post-purge then it will be turned off. The heater will remain in standby until a new call for heat occurs.

WATER LEAK DETECTION

Initially the control will have the leak detection function disabled by default. In this case the Leak Detection Module (LDM) associated errors E10, E11, and buzzer, are disabled as well.

As soon as an Leak Detection Module (LDM) is connected to the control, the Leak Detection



Function is automatically enabled. Errors E10, E11, and buzzer will be enabled as well. With the LDM connected, if the voltage at the LDM input falls below 1.45 V a “Water leak detected” alarm will be in place (E10 and Buzzer beeping continuously). This alarm will cease if the LDM input voltage rises above 1.55 V (leak condition ceased). Also when the owner acknowledges the event, he/she can silence the buzzer for 5 minutes by pushing the  button for 3 seconds. After 5 minutes, if the leak condition is still in place (LDM voltage < 1.45 V) the buzzer will start beeping continuously. A new push on the  button will silence the buzzer again for 5 minutes and so on. Once connected, if the LDM gets disconnected, the error E11 warning shall be in place (to let the owner know that the LDM function it is not operational). If for any reason the LDM should be unplugged on purpose, the LDM function and associated errors can be disabled by pressing the  button for 5 seconds. It will remain disabled until an LDM module is connected again.

Status	Voltage
Leak detected	< 1.45
Leak recover	> 1.55
LDM present	< 1.8
LDM unplugged	> 2
Vdc	3.3

TROUBLESHOOTING

CLEARING ERROR CODES

Hard Faults and Soft Faults can be cleared following two steps:

1. Unlock the control (by pressing the  button for 3 seconds), if the interface is locked
2. Press the  and  buttons simultaneously for 3 seconds.

Soft faults are also automatically cleared after 15 minutes after the fault condition occurred, if the conditions of the faults disappeared. If the fault condition is still set, the control will attempt to clear the Soft Faults after another 15 minutes (and so on).

Auto Reset faults are cleared automatically when the fault condition disappears.

Table 22. Error Codes

Code	Fault description	Meaning	Error type	Clear/Exit
E00	ECO (Dhw High-Limit)	$T > T_{max} 201^{\circ}\text{F}$	Hard Fault, Buzzer beeping once per second	Manual Action
E01	Flame out of sequence	Flame detected when it is not expected	Soft Fault	Reset in 15 minutes / Manual action
E02	Repeated Flame Loss	Lost flame 3 times in 5 minutes	Soft Fault	Reset in 15 minutes / Manual action
E03	Ignition failure	Failed to ignite “n” times in a row. (“n” is configurable for development only. It can be 1, 2, 3, 4, or 5)	Soft Fault	Reset in 15 minutes / Manual action
E05	Blocked flue	Outlet Air Pressure SW open 3rd time in less than one hour	Soft Fault	Reset in 15 minutes / Manual action
E06	Blocked flue	Outlet Air Pressure SW open, 1st and 2nd time	Auto Reset Fault	After post-purge
E07	Tank Temperature Probe (NTC) failure	Tank Temperature Probe (NTC) open or short or sensed temperature difference $> 4^{\circ}\text{C}$	Auto Reset Fault	When condition corrected
E10	Water leak detected	$V_{dc} < 1.45$	Warning, Buzzer beeping continuously	When $V_{dc} > 1.55$
E11	LDM open	$V_{dc} > 2\text{ V}$	Warning, Buzzer beeping once per second	When $V_{dc} < 1.8\text{ V}$, or long press on “Minus”
E19	Missing short circuit between X6.6 and X6.12	Missing short circuit between X6.6 and X6.12	Hard Fault, Buzzer beeping once per second	Manual Action
E20	Blower not running	Blower speed $< 200\text{ rpm}$ when blower powered	Hard Fault, Buzzer beeping once per second	Manual Action
E21	Blower speed error	Read speed not within $\pm 10\%$ of the Set speed for more than 10 seconds	Soft fault 3 times / Then Hard Fault	Reset in 15 minutes / Manual Action
E22	Blocked air inlet	Inlet Air Pressure SW open 3rd time in less than one hour	Soft Fault	Reset in 15 minutes / Manual Action
E23	Blocked air inlet	Inlet Air Pressure SW open, 1st and 2nd time	Auto Reset Fault	After ventilation as long as post-purge

TROUBLESHOOTING

Error Priority

If multiple error conditions arise at the same time, the Control will always give priority to hard faults over soft faults, and to soft faults over warnings, in ascending "class" priority sequence.

In case of multiple errors of the same "class" (for example 2 or more hard faults) at the same time, the Control uses the following priority table (higher priority first).

Table 23. Error Priority	
Hard Faults	
ECO error, T > Tmax (201F)	E00
Blower Speed error	E21
Blower not running	E20
Soft Faults	
Blower Speed Error	E21
Flame out of Sequence	E01
Repeated Flame Loss	E02
Ignition Failure	E03
Blocked Flue 3rd	E05
Blocked Flue, 1st, 2nd	E06
Blocked air inlet, 1st, 2nd	E22
Blocked air inlet 3rd	E23
Auto reset / Warnings	
NTC failure	E07
Water Leak detected	E10
LDM open	E11

If there are multiple error conditions at the same time, and at least one requires the buzzer, the buzzer will sound independent of the priority.

CHECKING FOR LEAKS

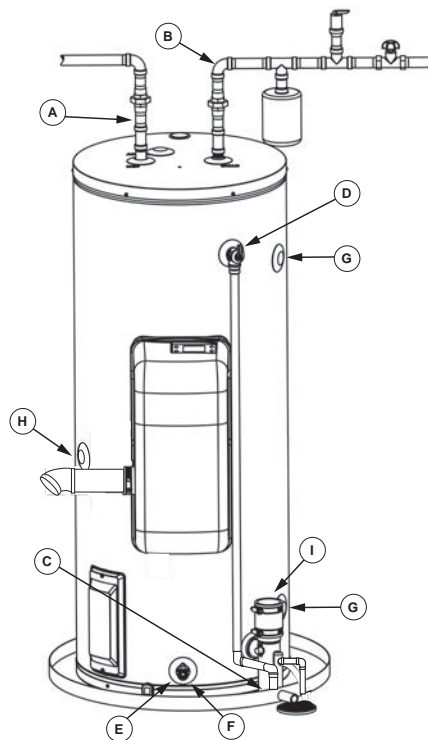

Figure 61. Leak Test Locations

- A. *Condensation may be seen on the hot water outlet pipe in humid weather or the hot water outlet connection may be leaking.
- B. *Condensation may be seen on the cold water inlet pipe in humid weather or the cold water inlet connection may be leaking.
- C. Small amounts of water from temperature-pressure relief valve may be due to thermal expansion or high water pressure in your area.
- D. *The temperature-pressure relief valve may be leaking at the tank fitting.
- E. Water from a drain valve may be due to the valve being slightly opened.
- F. *The drain valve may be leaking at the tank fitting.
- G. Leakage from recirculation plug or pipe connection.
- H. Leakage from the temperature probe connection.
- I. Condensate from the exhaust connection.

Leakage from other water heaters, water lines, or ground seepage should also be checked.

* To check where threaded portion enters tank, insert cotton swab between jacket opening and fitting. If cotton is wet, follow the instructions in *Draining the Storage Tank* (page 50) and then remove the fitting. Put pipe dope or thread-sealer tape on the threads and replace. Then follow the instructions in *Filling the Water Heater* (page 45).

⚠ WARNING

Safety Hazard

Improper installation, operation, alteration, or service might cause a malfunction that results in property damage, personal injury, or death.

Read and understand this instruction manual and the safety messages before installing, operating, or servicing this water heater. This manual must remain with the water heater.

Never use this water heater unless it is completely filled with water. To prevent damage to the tank, the tank must be filled with water. Water must flow from the hot water faucet before turning "ON" gas to the water heater.

DIAGRAMS

WIRING DIAGRAM

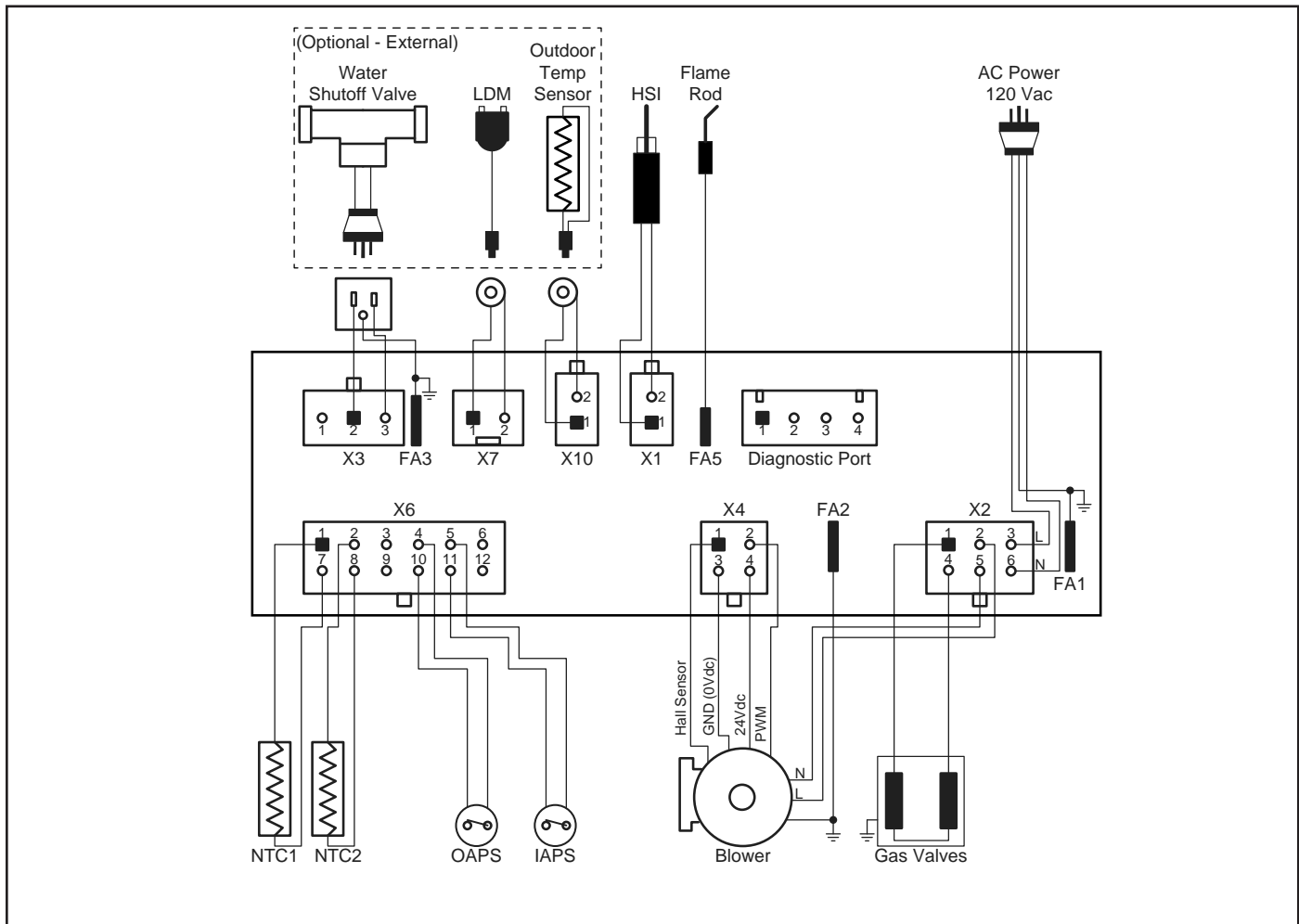

Figure 62. Wiring Diagram

SERVICE PARTS LIST

Table 24. Service Parts List	
Kit Number	Description
100344160	K,SIT BLOWER/GAS CONTROL VALVE,NG,0480.408 (Natural Gas Models Only)
100344191	K, IGNITER SIDEFIRE
100344192	K,FLAME SENSOR BENT
100344193	K,BURNER,4.5",STAINLESS STEEL,NG (Natural Gas Models Only)
100344194	K,GASKET,BURNER,1/2" THK
100368397	K,CONTROL BOARD,NG,50K (Natural Gas Models Only)
100368398	K,CONTROL BOARD,NG,65K (Natural Gas Models Only)
100344198	K,SWITCH, PRESSURE N.C, AIR INTAKE, -1.88" (Natural Gas Models Only)
100344199	K, SWITCH, PRESSURE N.C, FLUE,1.8" (Natural Gas Models Only)
100344200	K,THERMISTOR,3/4NPT
100344201	K,TRAP,CONDENSATE,POLYPROPYLENE
100344202	K,DIPTUBE,HT2,3/4NPTX3X34,PEX (40 Gal Models)
100344203	K,DIPTUBE,HT2,3/4NPTX3X46,PEX (50 Gal Models)
100300397	K,SEC ANODE OUTLET-16" -.80 DIA-5"NIP-MG (40/50 Gal Models)
100108660	K,ANODE-32"-3/4"NPT-.84DIA-MAGNESIUM (40 Gal Model)
100109223	K,ANODE-44"-3/4"NPT-.84DIA-MAGNESIUM (50 Gal Model)
100324744	K,POWERED ANODE, RES-LG,PROD PRES (OPTIONAL)
100346478	K,LEAK DETECTION
100368395	K,SIT BLOWER/GAS CONTROL VALVE,LP,0480.421 (LP Gas Models Only)
100368396	K,BURNER,4.5",FIBER COATED,LP (LP Gas Models Only)
100368399	K,CONTROL BOARD,LP,50K,CONFIGURED,SER121 (LP Gas Models Only)
100368400	K,CONTROL BOARD,LP,65K,CONFIGURED,SER121 (LP Gas Models Only)
100368411	K,SWITCH, PRESSURE N.C, AIR INTAKE, -1.62" (LP Gas Models Only)
100368412	K,SWITCH, PRESSURE N.C, FLUE, 1.43" (LP Gas Models Only)
100112508	K,BACKFLOW PREVENTER (LP Gas Models Only)

500 Tennessee Waltz Parkway,
Ashland City, TN 37015
• Technical Support: 800-527-1953
• Parts: 800-433-2545
• Fax: 800-644-9306
www.hotwater.com

Copyright © 2023 A. O. Smith Corporation. All rights reserved.